

4WD Ride with the Leader Hardware

Shock Absorber Installation Instructions

1. Note: Please read instructions thoroughly before installing shock absorber.
2. Remove old shock absorber from vehicle. Note any spacers, washers, sleeves or other hardware and note their location. Compare the existing hardware with the supplied hardware. Always use new hardware wherever possible. Due to the variety of applications, you may not use any or all of the hardware supplied. You may need to use some of the original hardware. If any of the original hardware is damaged, corroded, bent or broken it must be replaced.
3. If installing dust boot, do so at this time. (Note: The use of a lubricant like dish soap on the inside of the boot will ease installation.) Make sure the washer at the top of the shock is fully seated in the boot all the way around. Secure the bottom of the boot to the cylinder with a plastic tie strap.
4. Install any required bushings and sleeves in to the shock eyes at this time. Install the shock absorber on the vehicle. Use the appropriate illustration as a frame of reference. Due to the different shock mounts within a vehicle model range, the shock eyes must be built to match the shocks that you removed by using the universal hardware kit included. Choose the sleeve with an I.D. closest to the O.D. of the mounting stud or bolt without binding. Some applications will require some extra effort to install.
5. Check all fasteners for tightness before driving and inspect periodically.

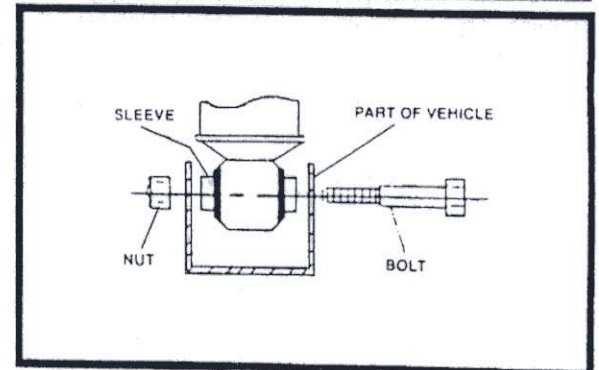
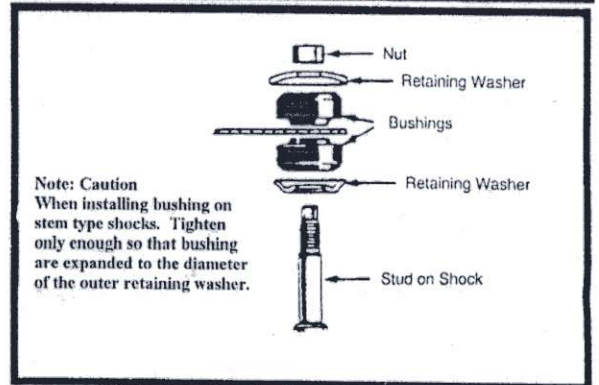
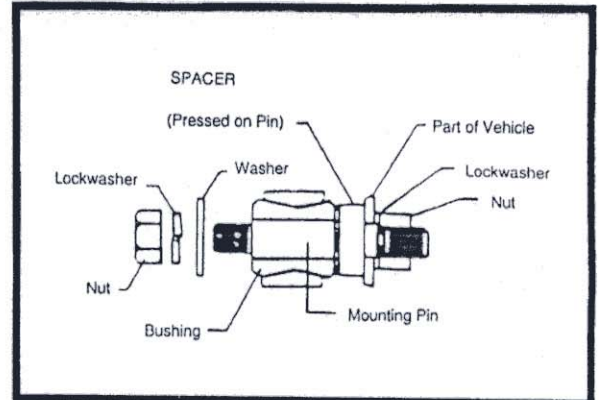

INSTALLING BUSHINGS, SLEEVE AND BARPINS

Some shock absorbers require multiple bushings, sleeves, and barpins, to be included in the kit due to vehicle years and model changes. After choosing the correct bushing, sleeve, and or barpin for your application, install it in the shock eye. For best results, begin by installing the bushing in the shock eye. Lubricant will ease this process. Next, lubricate the inside of the bushing and install the sleeve or barpin using a bench vise. Use care not to scratch or dent the shock body.

