



Dual Fueler Kit

Dodge Cummins 6.7L

- |                              |           |
|------------------------------|-----------|
| 2007.5 - 2010 kit w/no pump  | (2130030) |
| 2007.5 - 2010 package w/pump | (2130031) |

Installation Guide

## DISCLAIMER OF LIABILITY

***This is a performance product which increases horsepower above factory specifications. Additional horsepower creates more stress on your vehicle's drivetrain components which may result in drivetrain failure. Note: Legal in California only for racing vehicles which may never be used on the highway.***

This agreement sets forth the terms and conditions for the use of this product. The installation of this product indicates that the Buyer has read and understands this agreement and accepts the terms and conditions.

Pacific Performance Engineering Inc., its distributors, employees, and dealers (the "Seller") shall not be responsible for this product's improper use and service. The Buyer hereby waives all liability claims.

The Buyer hereby acknowledges no reliance on the Seller's skill or judgment to select or furnish goods suitable for any particular purpose and that there are no liabilities which extend beyond the description on the face hereof, and the Buyer hereby waives all remedies or liabilities expressed or implied, arising by law or otherwise (including without any obligation of the Seller with respect to fitness, merchantability and consequential damages), or whether or not occasioned by the Seller's negligence.

The Seller disclaims any warranty and expressly disclaims any liability for personal injury or damages. The Buyer acknowledges and agrees that the disclaimer of any liability for personal injury is a material term for this agreement and the Buyer agrees to indemnify the Seller and to hold the Seller harmless from any claim related to the item of equipment purchased. Under no circumstances will the Seller be liable for any damages or expenses by reason of use or sale of any such equipment.

The Seller assumes no liability regarding the improper installation or misapplication of its products. It is the installer's responsibility to check for proper installation and if in doubt, contact the manufacturer.

The Buyer is solely responsible for all warranty issues from the manufacturer.

## LIMITATION OF WARRANTY

The Seller gives Limited Warranty as to description, quality, merchantability, and fitness for a particular purpose, productiveness, or any other matter of Seller's product sold herewith. The Seller shall not be responsible for the products proper use and service and the Buyer hereby waives all rights other than those expressly written herein. This warranty shall not be extended, altered or varied except by a written instrument signed by Seller and Buyer.

The Warranty is limited to one (1) year from the date of sale and limited solely to the parts contained within the products kit. All products that are in question of Warranty must be returned prepaid to the Seller and must be accompanied by a dated proof of purchase receipt. All Warranty claims are subject to approval by Seller.

Under no circumstances will the Seller be liable for any labor charged or travel time incurred in diagnosis for defects, removal, or reinstallation of this product or any other contingent expenses.

Under no circumstances will the Seller be liable for any damage or expenses incurred by reason of the use or sale of any such equipment.

In the event that the Buyer does not agree with this agreement; the Buyer may promptly return this product, in a new and unused condition in its original packaging, with a dated proof of purchase to the place of purchase within ten (10) days from date of purchase for a full refund.

The installation of this product indicates that the Buyer has read and understands this agreement and accepts its terms and conditions.

**DUAL FUELER KIT - PARTS LIST:**



- |     |                                   |     |                                   |
|-----|-----------------------------------|-----|-----------------------------------|
| 26. | 8" Zip Ties (3)                   | 39. | H.P. Fuel Line 515-006-2170 (1)   |
| 5.  | 5/16" x 18 x 2 Bolt (2)           | 41. | H.P. Fuel Line 515-006-2712 (1)   |
| 25. | 8 x 0.5" Self – Tapping Screw (2) | 31. | Fuel Return Tube (1)              |
| 6.  | 5/16" x 18 x 2.25" Bolt (1)       | 19. | Fuel Line Bracket (1)             |
| 8.  | 18 x 1.5 Nut (1)                  | 29. | MOD Dipstick Bracket (1)          |
| 16. | 5/16" x 18 Nut (3)                | 34. | Z – Bracket (1)                   |
| 11. | 5/16" Washer (3)                  | 42. | H.P. Fuel line 515-006-2173 (1)   |
| 9.  | 18mm washers (1)                  | 36. | 21" x 5/16" Fuel Hose (1)         |
| 21. | 5/16" Brass Fuel Tee (2)          | 35. | 18" x 5/16" Fuel Hose (1)         |
| 22. | 5/16" Hose Clamp (16)             |     | 9" x 5/16" Fuel Hose (1)          |
| 13. | 10mm Washer (1)                   |     | 8" x 5/16" Fuel Hose (1)          |
| 7.  | 10 x 1.50 x 25 Bolt (3)           |     | 7" x 5/16" Fuel Hose (1)          |
| 14. | 8 x 1.25 x 12 Bolt (1)            |     | 2.5 x 5/16" Fuel Hose (1)         |
| 18. | 6 – 1.0 x 25 Bolt (1)             | 43. | Coolant Reroute Tube – Double Tab |
| 23. | 2.25" Hose Clamp (3)              | 46. | Serpentine Belt 2003-2010         |
| 24. | 2.5" Hose Clamp (1)               | 47. | Duel Fueler Pump Bracket          |
| 32. | H.P. 3 Way Fuel Block (1)         | 48. | Duel Fueler Pump Pulley           |
| 49. | Idler Pulley (1)                  | 50. | Coolant Hose – "L" Shape          |
| 34. | Duel Fueler Controller (1)        | 51. | Coolant Hose - Short              |

**Step 1**

Disconnect both batteries (positive terminals).

**Step 2**

Drain coolant system.

**Step 3**

Disconnect fan harness connector located under the truck.



**Step 4**

Remove four 13mm fan shroud bolts. 2 bolts on the bottom of the fan shroud (below the truck), 2 bolts on the top of the fan trail (under the hood).

**Step 5**

Remove radiator clamps and hose.

**Step 6**

Remove EGR pipe clamps. Remove EGR pipe.



**Step 7**

Remove EGR valve. Remove intake manifold to access the fuel lines.



**Step 8**

Remove the fan shroud bracket. (2x 13mm bolts)  
Remove the fan and shroud.



**Step 9**

Remove all six 8mm bolts from fan pulley adapter.

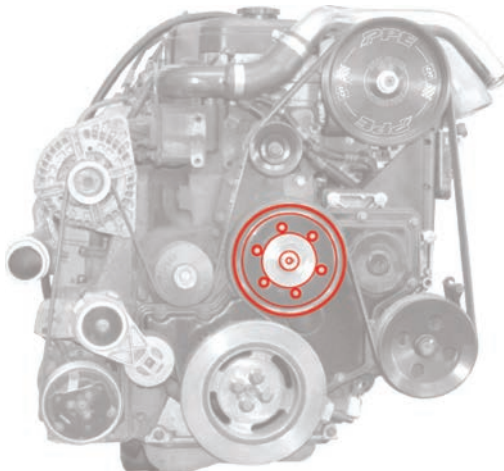

### Step 10

Remove the fan pulley and belt.

### Step 11

Now that the EGR/intake assembly has been removed from the engine, you will be able to access the fuel feed and return line coming from the fuel filter housing.

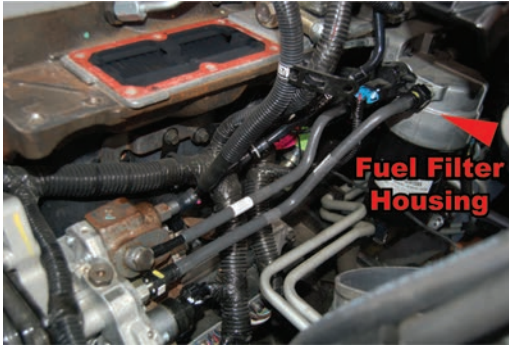

### Step 12

Remove stock fuel pressure line from the fuel rail.



### Step 13

Remove stock **FUEL FEED LINE** from fuel filter housing and replace with the PPE fuel feed line provided in the kit.

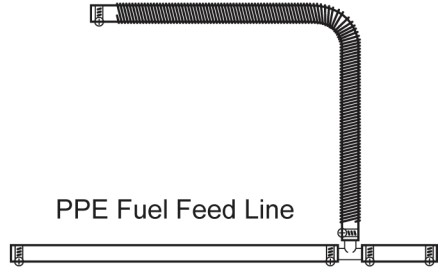
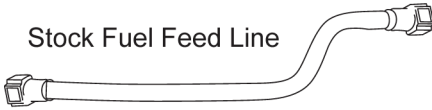

### Step 14

Remove the stock **RETURN LINE** from fuel filter housing and then replace with the PPE return line using stock seal and 17mm bolt.

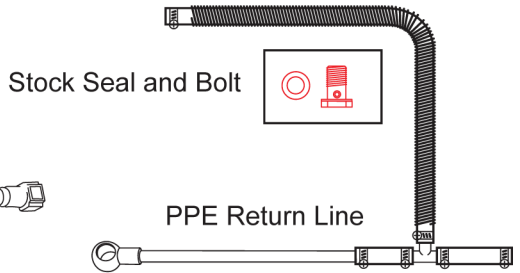
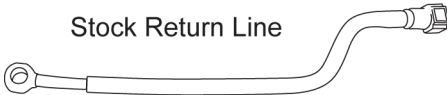

### Step 15

Install fuel pressure line. (Follow diagram below)

Note: Line going to the PPE aftermarket pump will not be connected until pump is installed.

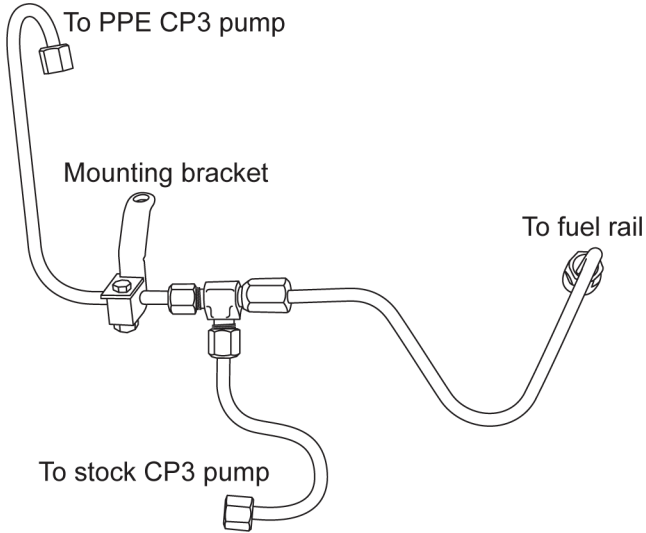

### Step 14

Install intake manifold and EGR. Install fuel pressure line mounting bracket.

Note: CP3 Pump bracket will mount to this area on the block. (see image) Three 17mm bolt holes.

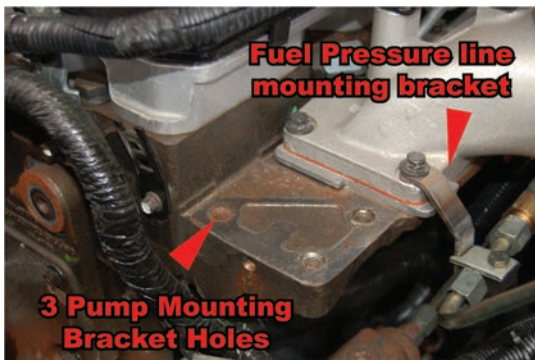



### Step 15

Install the bracket as shown below.



### Step 16

Mount pump on bracket as shown.



## PUMP ASSEMBLY

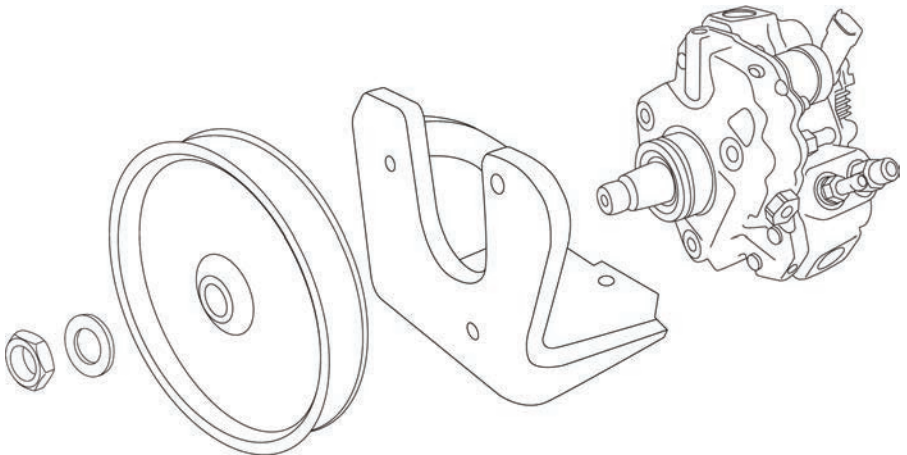

### Step 17

Install fuel lines to both CP3 pumps, follow diagram below.

Note: CP3 pump wheel nut will be torqued later when the belt is installed.

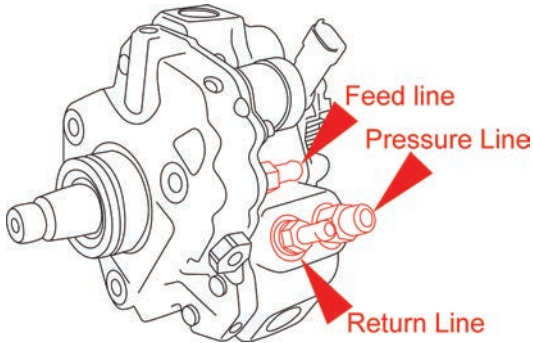

### Step 17

Optional high flow fuel feed line fitting can be installed now.

Remove stock feed line fitting. Install the PPE high flow fitting.

Note: Blocker plate solution, as shown, is for racing purposes only. Block off plates not included in kit.



### Step 18

Find a suitable area by the battery to mount the control module. Connections are as follows.

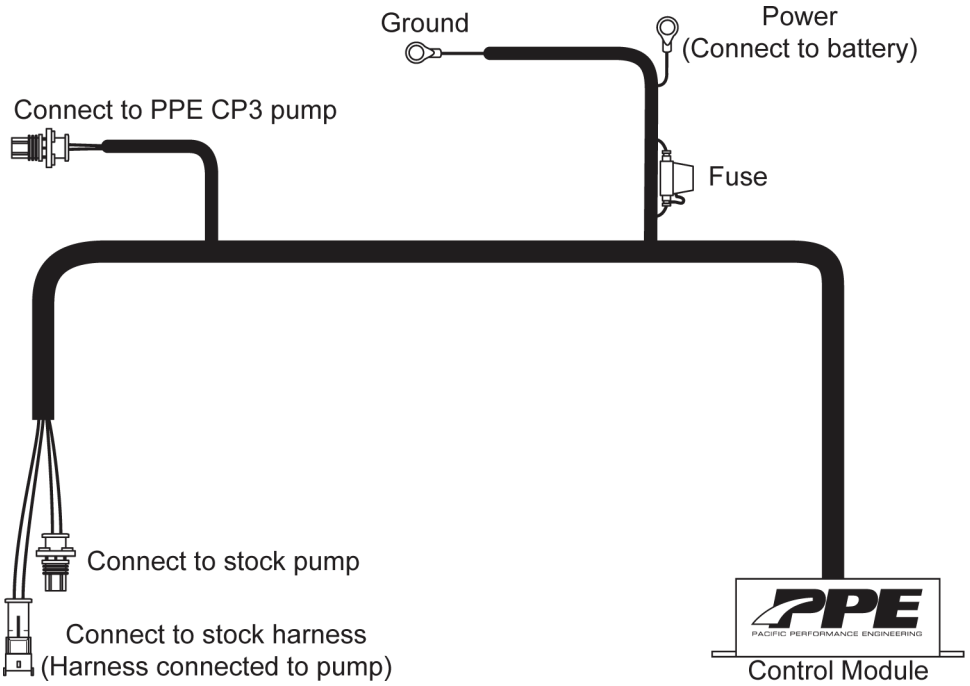

### Step 19

Remove stock idler pulley. Install PPE idler pulley provided in kit. (use stock bolt, washer, and spacer with PPE pulley)

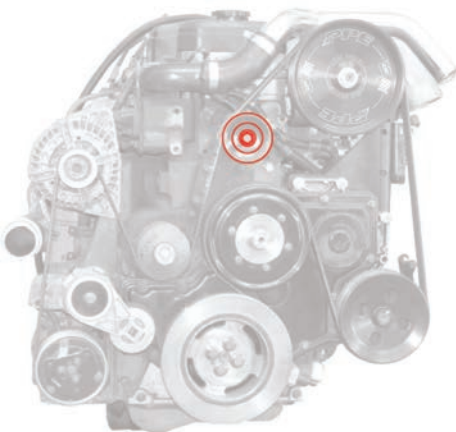

Install pulley in original location. (See figure on left)

### Step 20

Install the PPE drive belt that was provided with the kit.  
Use belt routing diagram below.

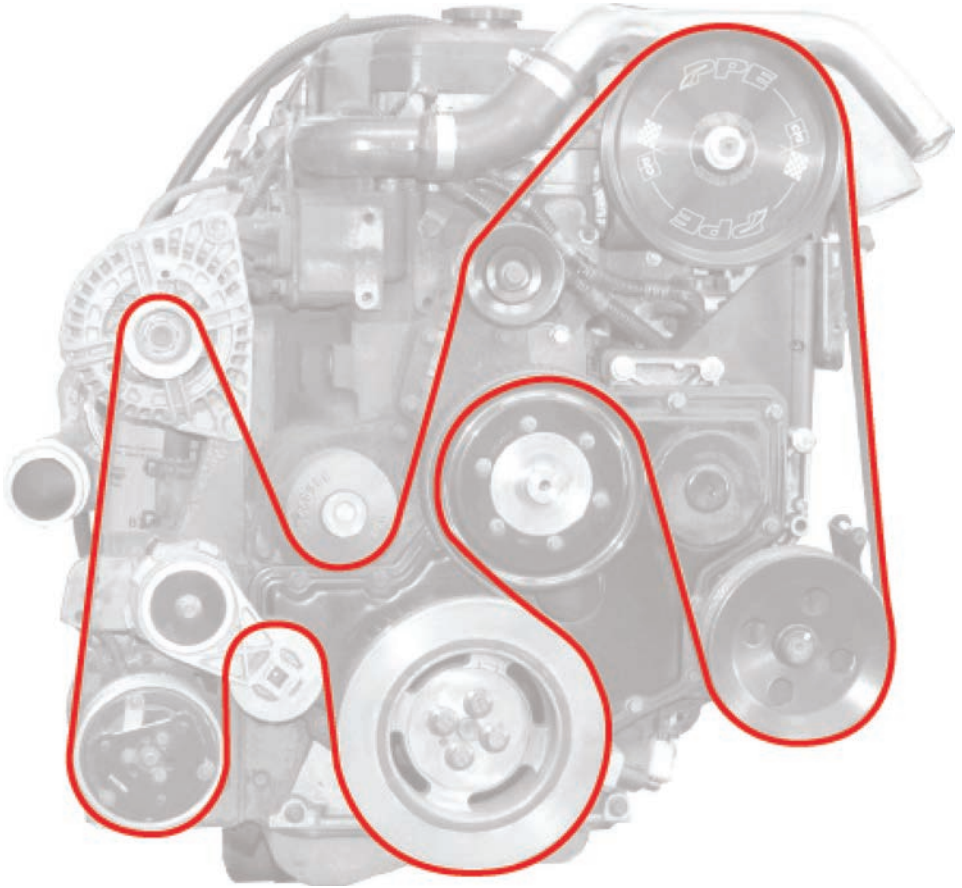

### Step 21

Once the new belt is installed, next is the fan pulley adapter that was removed in Step 9. Install fan, fan shroud and fan shroud bracket.

### Step 22

Torque CP3 pump wheel nut.

## Step 22

Install the PPE coolant pipe, hoses, and clamps.



## Step 23

Install the oil dipstick bracket.



**Fill coolant system. Connect batteries. Installation is complete.**