



STAGE 5 [TRANSMISSION KIT](#)
INSTALLATION GUIDE

2006-2010 Allison LBZ/ LLM

DISCLAIMER OF LIABILITY

This is a performance product which can be used with increased horsepower above and beyond factory specifications. Additional horsepower creates more stress on the drivetrain components, which could result in drivetrain failure. Legal in California only for racing vehicles which may never be used on the highway.

This agreement sets forth the terms and conditions for the use of this product. The installation of this product indicates that the Buyer has read and understands this agreement and accepts the terms and conditions.

Pacific Performance Engineering Inc., its distributors, employees, and dealers (the "Seller") shall not be responsible for the product's proper use and service. The buyer hereby waives all liability claims.

The Buyer hereby acknowledges no reliance on the Sellers skill or judgment to select or furnish goods suitable for any particular purpose and that there are no liabilities which extend beyond the description on the face hereof, and the Buyer hereby waives all remedies or liabilities expressed or implied, arising by law or otherwise (including without any obligation of the Seller with respect to fitness, merchantability and consequential damages), or whether or not occasioned by the Seller's negligence. The Seller disclaims any warranty and expressly disclaims any liability for personal injury or damages. The Buyer acknowledges and agrees that the disclaimer of any liability for personal injury is a material term for this agreement and the Buyer agrees to indemnify the Seller and to hold the Seller harmless from any claim related to the item of equipment purchased. Under no circumstances will the Seller be liable for any damages or expenses by reason of use or sale of any such equipment. The Seller assumes no liability regarding the improper installation or misapplication of its products. It is the installer's responsibility to check for proper installation and if in doubt contact the manufacturer.

The Buyer is solely responsible for all warranty issues from the manufacturer.

LIMITATION OF WARRANTY

The Seller gives Limited Warranty as to description, quality, merchantability, and fitness for a particular purpose, productiveness, or any other matter of Seller's product sold herewith. The Seller shall not be responsible for the products proper use and service and the Buyer hereby waives all rights other than those expressly written herein. This warranty shall not be extended, altered or varied except by a written instrument signed by Seller and Buyer.

The Warranty is limited to two (2) years from the date of sale and limited solely to the parts contained within the products kit. All products that are in question of Warranty must be returned prepaid to the Seller and must be accompanied by a dated proof of purchase receipt. All Warranty claims are subject to approval by Seller. Under no circumstances will the Seller be liable for any labor charged or travel time incurred in diagnosis for defects, removal, or reinstallation of this product or any other contingent expenses.

Under no circumstances will the Seller be liable for any damage or expenses incurred by reason of the use or sale of any such equipment. In the event that the buyer does not agree with this agreement: the buyer may promptly return this product, in a new and unused condition in its original packaging, with a dated proof of purchase to the place of purchase within ten (10) days from date of purchase for a full refund. The installation of this product indicates that the buyer has read and understands this agreement and accepts its terms and conditions.

Step 1

After the torque converter is removed place the transmission into a holder or stand it up in a drain pan on floor. Place transmission with bell housing down. Remove the rear extension housing as an assembly. Remove park pawl pin, park pawl, C5 return spring assembly. Remove P3 sun gear and thrust bearing.

NOTE: Pay attention to the directional install of Torrington bearing. Inverting bearings will result in Extreme Damage.

Grasp the main shaft splines and lift straight up to remove the main shaft, P2 sun gear and spacer. Remove P2 planet carrier and thrust bearing. Remove C5 clutch pack and backing plate. Remove P1 planet carrier assembly and thrust bearing. By lifting up with a slight twisting motion leaves the P1 ring gear in place.

We recommend performing all C4 clutch modifications first.

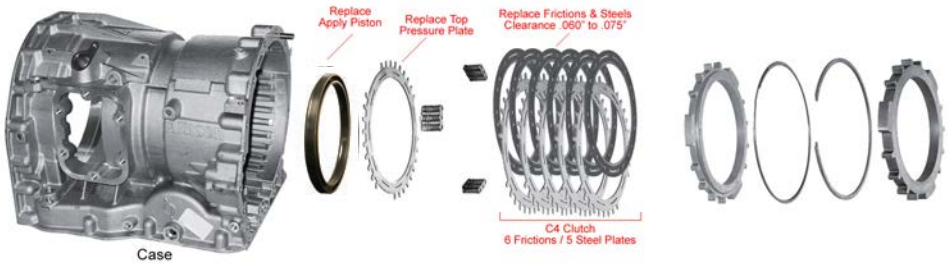

Step 2

Remove the C4 retaining rings while compressing the backing plate. Remove the C4 clutch pack. Remove the C4 piston. Remove 3 spring sets from Apply Plate. Discard OEM Apply Plate and Clutch Pack.

Remove plastic thrust washer from the front of the P1 carrier. Using assembly gel install the washer onto steel shim provided, index tangs on washer to slots in shim. Apply assembly gel to the rear side of the shim and install onto the P1 carrier (shim towards carrier) indexing into the slots on the carrier. Make sure the shim and washer are all the way (down) evenly onto the carrier. Install thrust bearing to the rear of the P1 carrier, retaining with assembly gel. Install P1 the carrier into the P1 ring gear in case.

Lubricate and install C-4 piston furnished with the Air Bleed hole into line the with top of case at the 12 o'clock position. Install return springs onto the new .250 Pressure Plate and install with groove side up. Install C-4 clutch pack (furnished). Starting with Friction against Apply Plate and alternating with Kolene® Steel.

(Continue Step 2 next page)

Step 2 (Continued)

We recommend soaking Frictions in ATF for a 30 minutes prior to installation. When installing Frictions and Steels, align the slots in each plate with holes in Apply Plate at the 12 o'clock position. Install 6 Frictions and 5 Steels. Install and compress the C-4 backing plate, install Spiral Ring and then the Snap Ring. Position gap in Snap Ring should be at the 1:30 position, aligning with a wide gap in the case. Clearance should be from .060" to .075".

Reassemble the rear section, be sure to align the slot in Sun Gear Spacer with lube hole in Shaft Shoulder, when installing extension housing. The housing will be spring loaded for the last 1/2" above case. GENTLY pull down evenly with speed handle until flush. Torque to 45 ft.lbs.

Step 3

Remove oil pan (12 x 13mm bolts)

Step 4

After a few years of service, wiring gets brittle. CAREFULLY disconnect all electrical connections from the VB. Remove bolts. After bolts are out, wiggle VB to lift it off the dowels. Careful not to lose Manual Valve Link when removing VB.

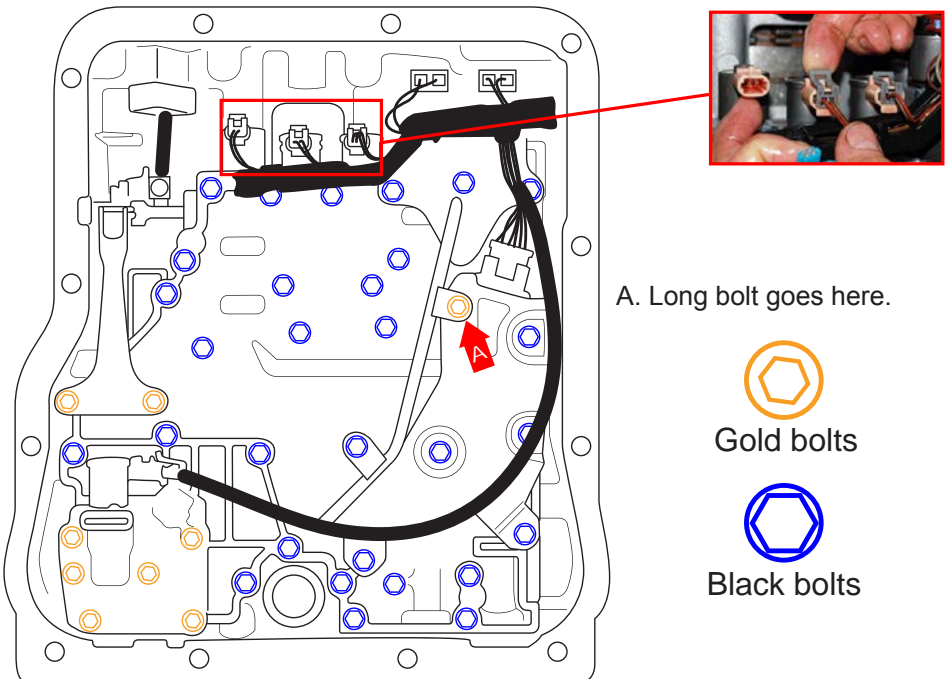

Step 5
Remove tube.

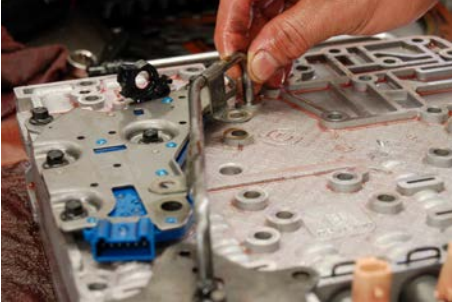

Step 6
Remove Pressure Switch.

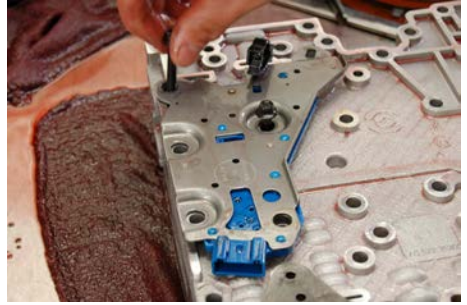

Step 7
Separate the VB to access the Separator Plate.



Step 8
Enlarge two holes on separator plate with the smaller drill furnished (.125).

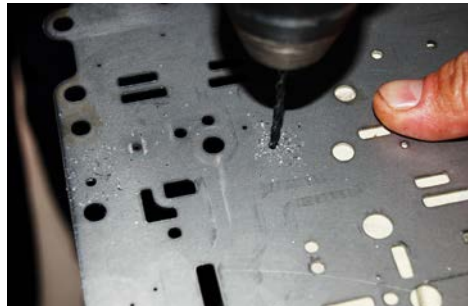
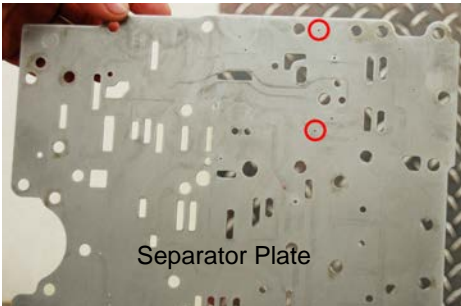

Step 9

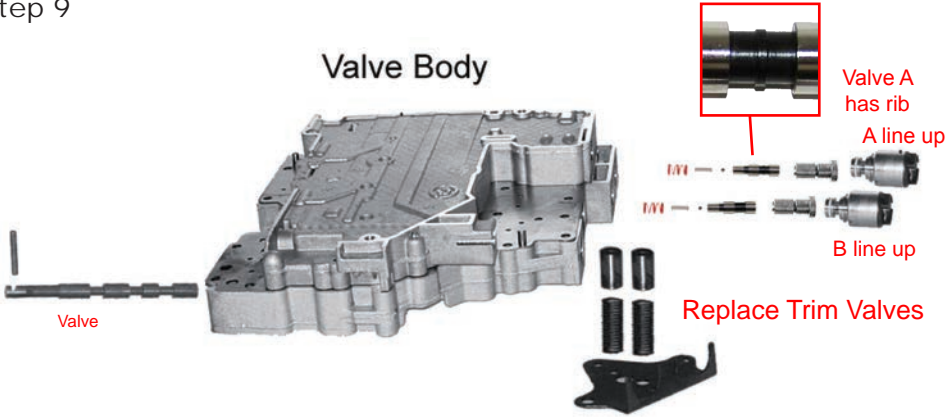

Discard original trim valves and the springs from the small end of the valves. Place new ball bearings the small spring into the hollow end of the new trim valves. Use transmission gel (or petrolium jelly) to hold ball bearing in place. Insert new outer springs over the small end of the trim valves. Install the assembly into the Valve Body. Don't force them, a little wiggle and they will drop in. Install outer spring, solenoid valves and solenoids as shown. Outer spring must be installed in the "A" Line up.

Step 10

With the bell housing off the trans, remove 10 bolts in the bell housing, these bolts have O-Rings under bolt heads.

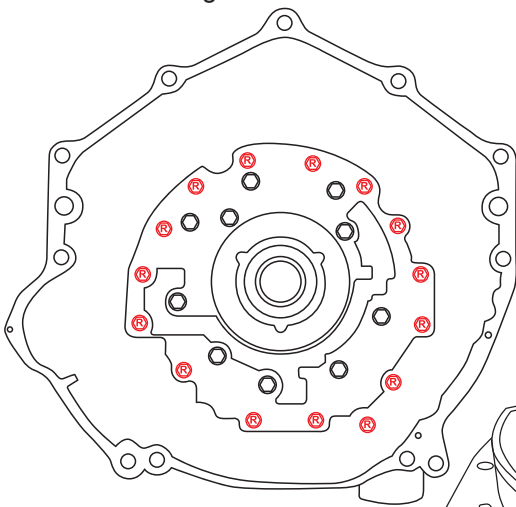

Bell housing - Front View

Step 11

Remove 5 bolts from rear. Lift off stator and flip it over.

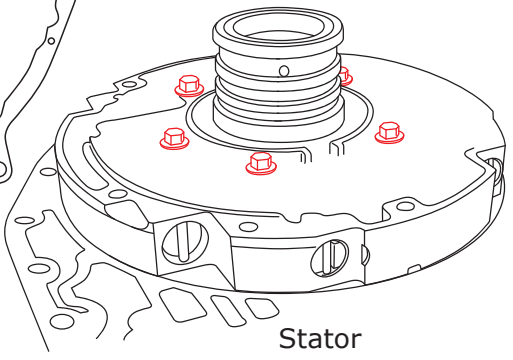

Stator

Step 12 - C1 Disassembly

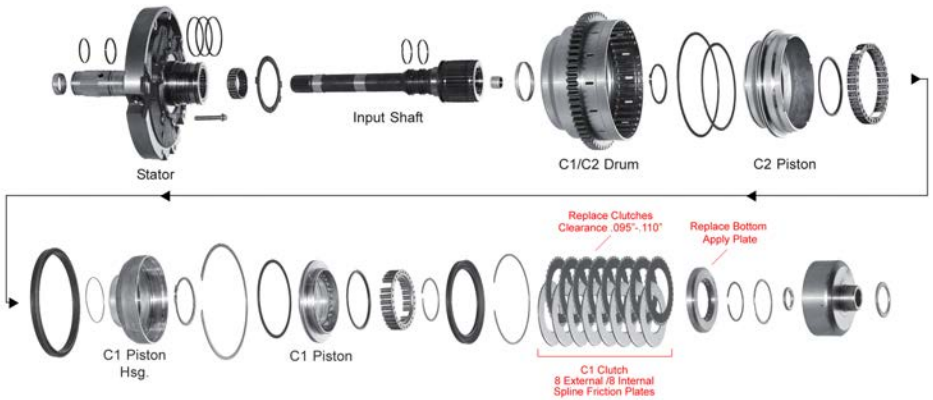

Step 13

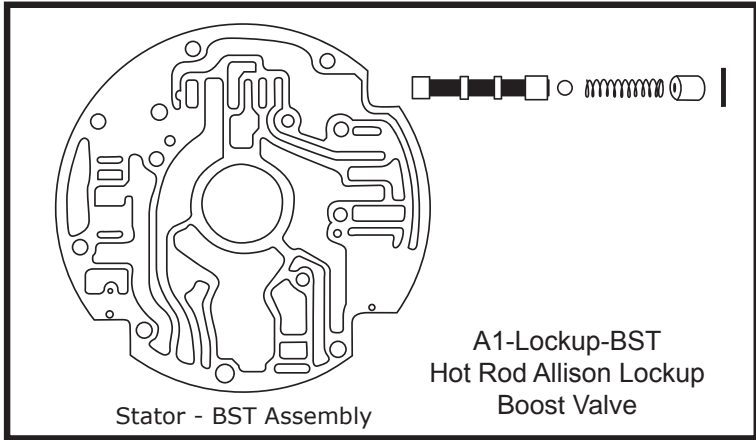

Remove and discard the original Converter Flow Valve, Spring and End Plug. Install the New Valve, 3/8" Check Ball, Spring and new End Plug. Reuse pin.

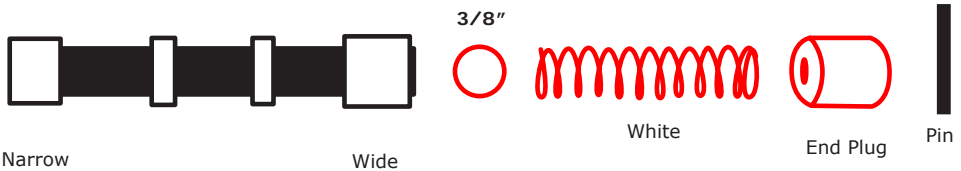

Step 14

Remove the Converter housing and Stator support assembly. If your Stator has the early style Babbitt bushing, replace it with a new stator support bushing (not furnished). It is not necessary to remove pump from Converter housing. Using PTO cover bolt, install as illustrated. Depress main regulator valve stop and remove retaining pin. Remove valve stop, no need to remove spring or valve. Install steel shim on spring side of Plug, Reinstall Plug and Retaining Pin.

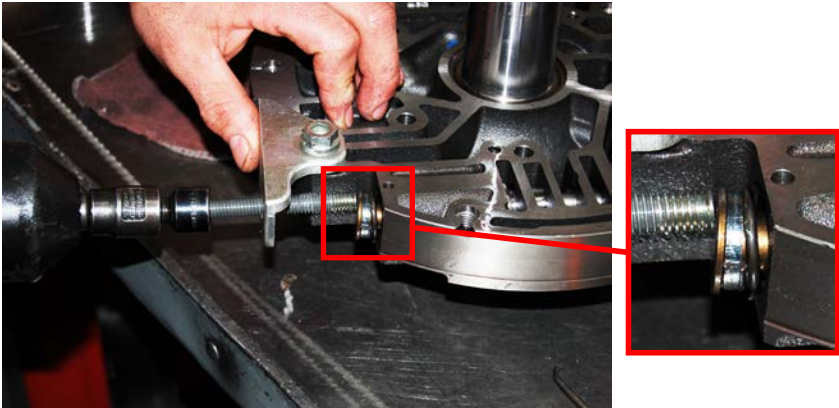

Make sure all valves are free. Remove the rotating clutch module from transmission by lifting and wiggle as you lift to avoid disturbing the main shaft lube to the spacer position. Do not lift up on the main shaft. Disassemble the rotating module and modify as per Valve Body Kit instructions. Converter housing on bench provides a nice stand for working on and testing the module.

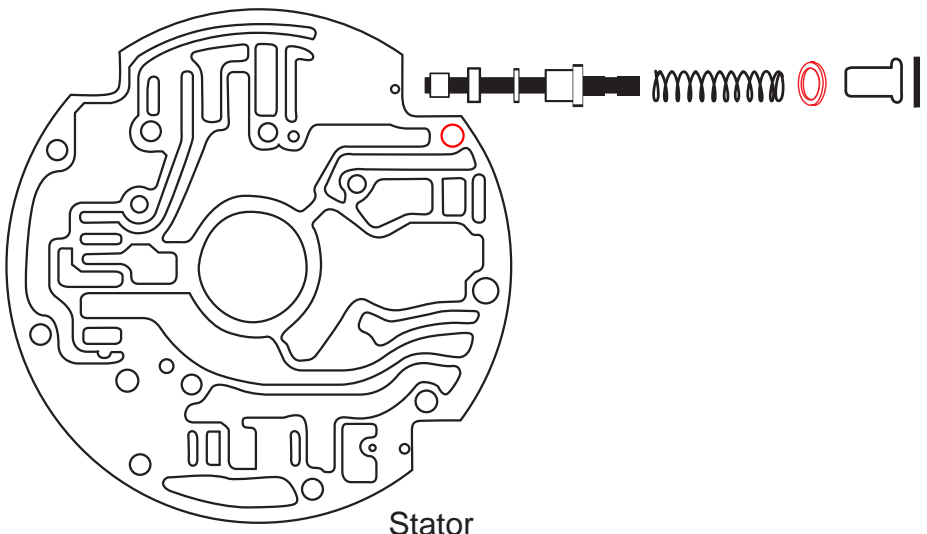

Step 15

Re-assemble the Stator support to housing with a new gaskets and install into transmission. There have been a few of these leaking from the bell housing bolts due to roughness in the casting. A little silicone under the bolt heads is highly recommended.

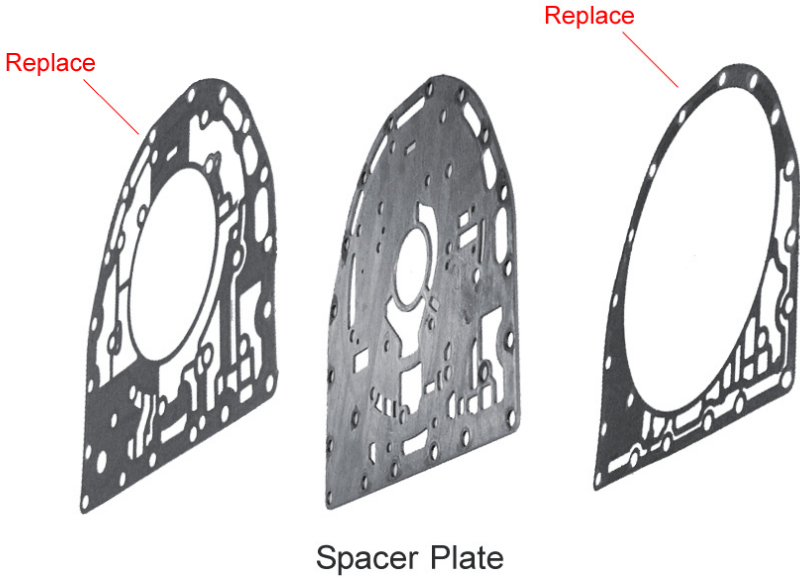

Step 16

Assemble Stator, C1/C2 using the diagram below. Replace C1 clutches and Bottom Apply Plate. (Clearance .095"-.110")

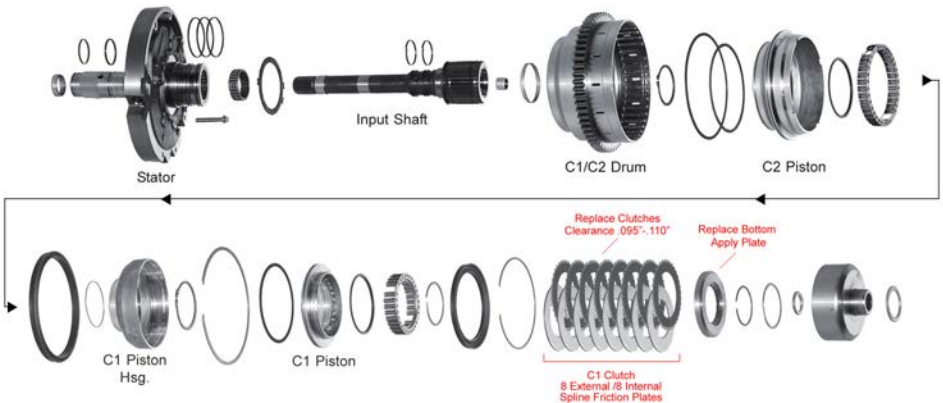

Step 17

Install the stepped Apply Plate flat side up. Make sure the bearing is on top of the C-1 hub. Install the C-2 hub and start the clutch ordering with a Friction against Apply Plate. Alternate Kolene® Steel and Frictions (8 Frictions and 8 Steels), ending with a Steel Plate on top. Install a bronze washer on the C2 hub. Install the P1 Plate, Sun Gear and Snap Ring. Clearance should be from .070" to .085".

With rotating module in Converter housing you may air check the C-1 and the C-2 with a rubber tipped blow gun. 3/8" hole should be at the 7 o'clock position for the C1, C2 needs to be at the 5 o'clock position.

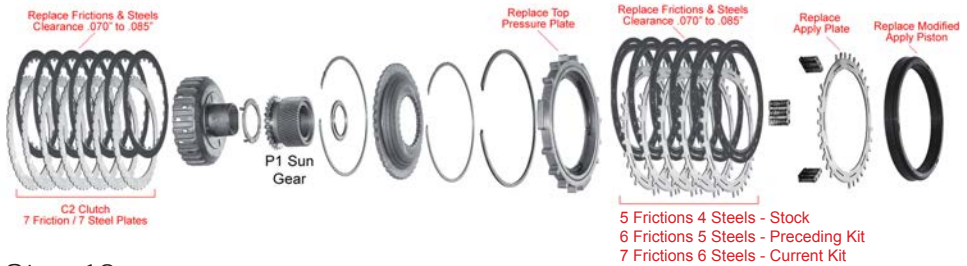

Step 18

Depress the C3 Top Plate and remove the Snap Ring, Top Plate, Clutch Pack, Apply Plate, Springs and the C3 piston. Install the C3 piston (furnished), (bleed hole needs to be at the 12 o'clock position) install return springs onto new .125" Apply Plate (furnished). Install Apply Plate groove side up. Install the Frictions and Steels in same manner as the C4; 6 Frictions and 5 Kolene® Steels. Aligning the slots with a 12 o'clock hole position. Install the C3 Pressure Plate (furnished). Depress the plate and install the Snap Ring with the gap at the 1:30 position. Clearance should be from .065" to .075".

Retain the bearing with assembly gel. Install the rotating module, making sure module is fully seated. Install Converter housing with new gasket and torque to 45 ft.lbs. Check end play @ turbine shaft (.011" - .060") Perform Valve Boy Modifications per Valve Body Kit instructions.

NOTE: Retain the C1, C3 Pressure Plates and C3, C4 Apply Pistons for core deposit refund.

Step 19

IMPORTANT: Do not start the engine unless the transmission has been filled with transmission oil, minimum 16 quartz with Shallow Pan. 18 quartz with Heavy Duty DEEP pans. Such as PPE aluminum pans.

Step 20

Complete the assembly and return the modified transmission to its original position on your vehicle. Installation complete once the oil is filled to the correct level.

NOTE: To read and clear codes use the PPE's Xcelerator tuner. Transmission relearn procedure will take up to 2 hours, the PPE's Xcelerator tuner can speed up the process by using the re-set transmission procedure.

PPE Recommended Upgrades

Transmission Pan (Allison™)

Features:

- Increased fluid capacity, runs up to 20 degrees cooler
- Easy to service
- High temperature drain plug magnet attracts metallic particles
- 1" ID port is large enough to use for filling
- Anodized finish for corrosion protection and added heat rejection
- Uses high quality re-usable OEM gasket
- Plugs, cap screws, and washers are stainless steel
- 2001-2011 Allison™ 1000 Transmission

The new Heavy Duty PPE Transmission pan is cast from A356-T6 aluminum alloy. Fluid capacity is increased by 4 quarts. The robust side ribs provide added strength to transmission. 1 1/4" high-internal heatsink baffles absorb heat and channel oil flow to filter oil pick-up port. 3/4" deep-bottom heatsink, with flow through channels, dissipates heat into passing air flow. Bare aluminum finish significantly reduces transmission oil temperatures. 1/4"NPT and 1/8"NPT threaded ports for gauge sensors. Retains use of high quality original Allison pan gasket.



PPE DEEP TRANSMISSION PAN
Includes Allison DEEP Pan Filter and
Installation Hardware. (Part #1280510)

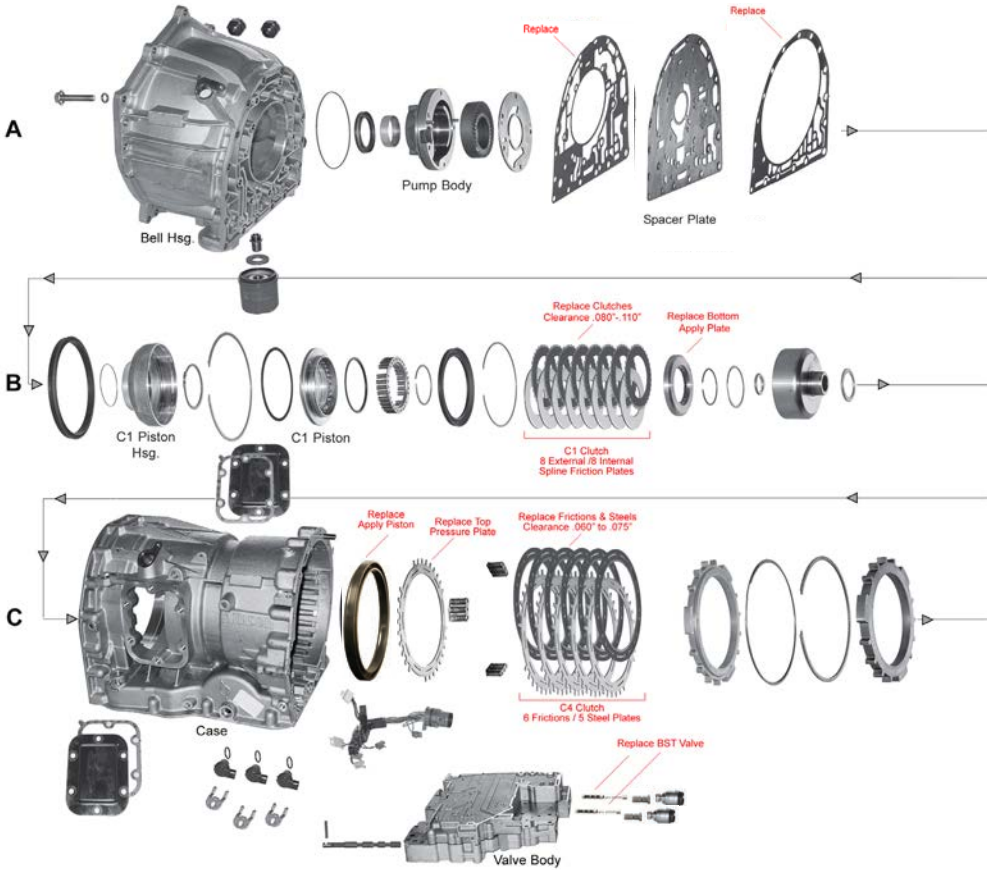

****NOTE: RETAIN C1/C3 TOP PRESSURE PLATES AND C3/C4 APPLY PISTONS FOR CORE DEPOSIT REFUND!****

*****NOTE- Use the torque converter bolts that are supplied.*****

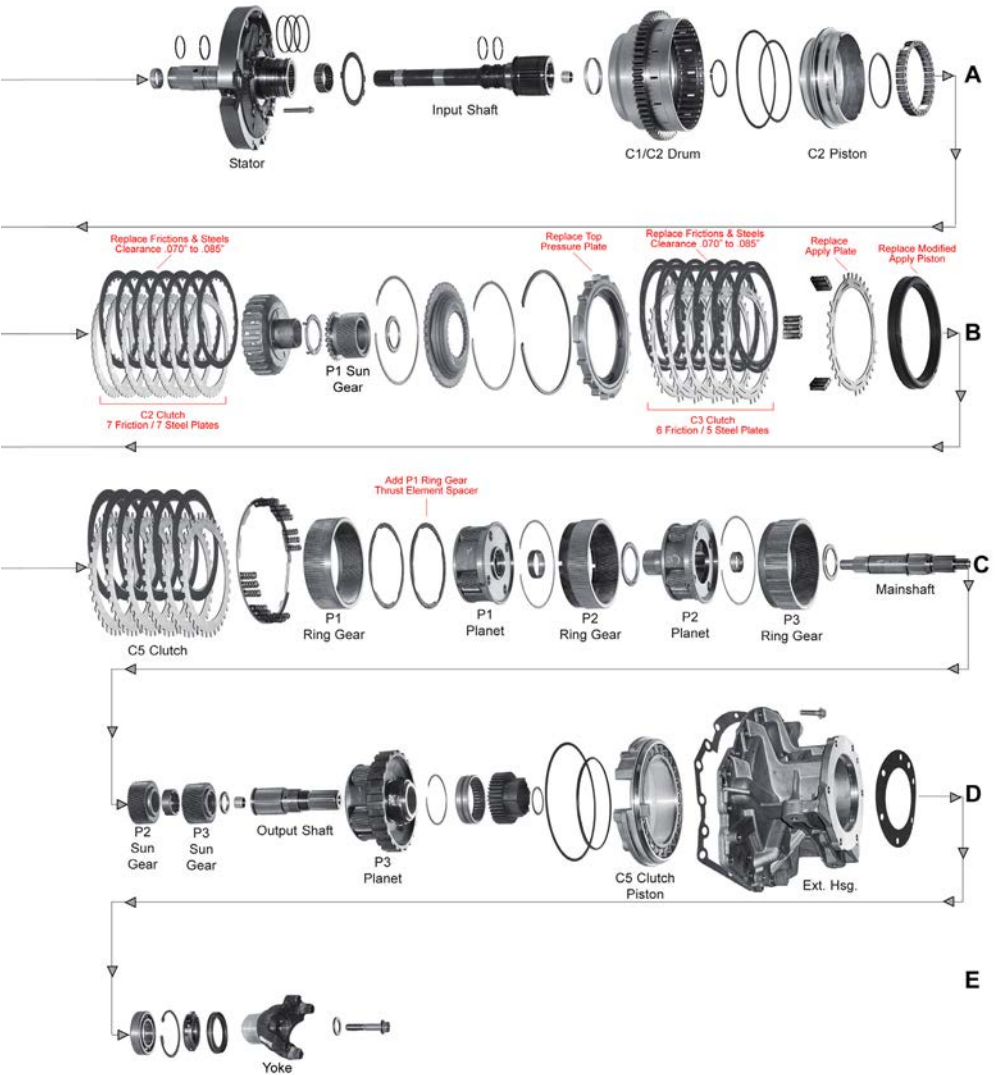

PPE Recommended Upgrades

GM Performance Transmission Cooler

Keep your transmission cool with PPE's performance transmission cooler. Lower your transmission operating temperature with this bolt on replacement. 60% increase in heat rejection surface lowers temperatures by 20-30 degrees. This easy installation only takes about 30 minutes.

Available for 2001-2009 Duramax diesel engines.

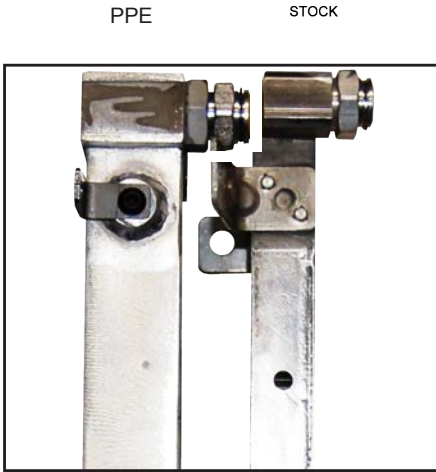

Top View

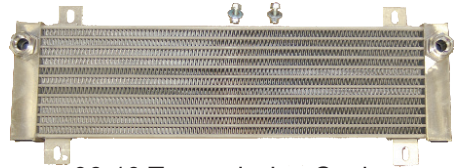

06-10 Transmission Cooler

Billet Input Shaft (TGBIS)

The Billet Input shaft is for high performance transmissions, helping to withstand higher horsepower and torque levels for towing or racing. This shaft is highly recommended when installing Stage4 or Stage5 transmission kits.

Available for 2001-2009 Allison 1000 5 and 6 speed transmissions.

