

Performance Transmission Cooler Bar and Plate

(124063000)

2011-2014 LML GM 6.6L

Allison 1000/2000 Series

Installation Guide



DISCLAIMER OF LIABILITY

Performance products can increase horsepower above and beyond factory specifications. Additional horsepower creates more stress on the drive-train components, which could result in drive-train failure.

Note regarding emissions-related, non-E.O.-legal products: THESE PRODUCTS ARE LEGAL IN CALIFORNIA ONLY FOR RACING VEHICLES THAT MAY NEVER BE USED, OR REGISTERED OR LICENSED FOR HIGHWAY OR OFF-ROAD USE.

This agreement sets forth the terms and conditions for the use of PPE products. The installation of this product indicates that the Buyer has read and understands this agreement and accepts the terms and conditions. PPE (Pacific Performance Engineering) Inc., its distributors, employees, and dealers (the "Seller") shall not be responsible for the product's proper use and service. The buyer hereby waives all liability claims. The Buyer hereby acknowledges no reliance on the Seller's skill or judgment to select or furnish goods suitable for any particular purpose and that there are no liabilities which extend beyond the description on the face hereof, and the Buyer hereby waives all remedies or liabilities expressed or implied, arising by law or otherwise (including without any obligation of the Seller with respect to fitness, merchantability and consequential damages), or whether or not occasioned by the Seller's negligence. The Seller disclaims any warranty and expressly disclaims any liability for personal injury or damages. The Buyer acknowledges and agrees that the disclaimer of any liability for personal injury is a material term for this agreement and the Buyer agrees to indemnify the Seller and to hold the Seller harmless from any claim related to the item of equipment purchased. Under no circumstances will the Seller be liable for any damages or expenses by reason of use or sale of any such equipment. The Seller assumes no liability regarding the improper installation or misapplication of its products. It is the installer's responsibility to check for proper installation and if in doubt, contact the manufacturer. The Buyer is solely responsible for all warranty issues from the manufacturer.

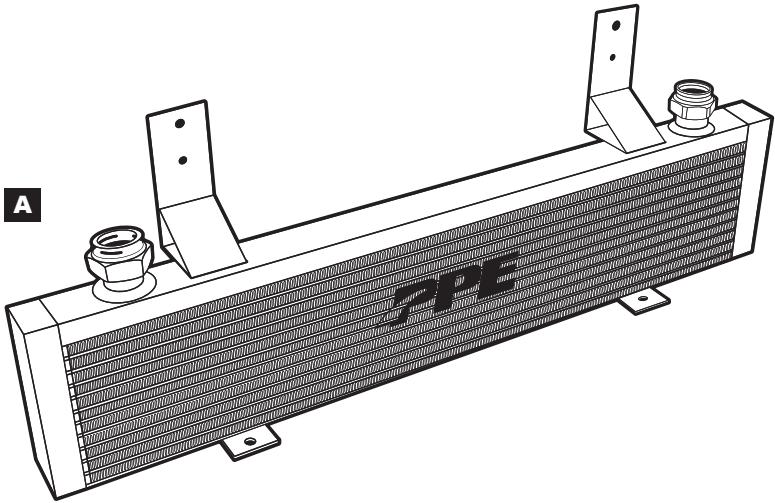

CONTENTS

- A: Bar and Plate style Transmission Cooler (1) with transmission cooler line fittings and clips (2) already installed.

Disassembly

Step 1 Vehicle off. Engine cool.

Step 2 Disconnect fog lights, remove grill, radiator cover, bumper and bracket.

Step 3 Remove clips and disconnect both driver and passenger transmission cooler lines.

Wrap using a rag or towel around the ends of the cooler lines to reduce transmission fluid leaking during installation.



Step 4 Remove stock driver and passenger upper bolts.

Save for later reinstallation.



Step 5 Remove both clip nuts.

Save for later reinstallation.



Step 6 Remove both rubber cushions.

Save for later reinstallation



Step 7 Remove transmission line retaining clip from the back, passenger side stock transmission cooler bracket.

Save for later reinstallation.



Installation

Step 8 Remove PPE fittings. Apply anti-seize to both. Install and tighten both to 80 inch lbs.



Step 9 Install both saved stock rubber cushions on driver and passenger side lower, rear Transmission Cooler brackets.



Step 10 Install saved stock clip nuts on the driver and passenger side Transmission Cooler brackets.



Step 11 Install saved transmission line stock retaining clip on the passenger side Transmission Cooler bracket.



Step 12 Install assembled Transmission Cooler. Position so that the stock rubber cushions and stock slip nuts line up with their mounting holes. Route transmission lines as shown. Install and tighten hardware to secure.



Step 13 Secure passenger side transmission line on reinstalled factory clip.

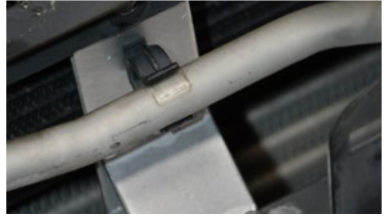

Step 14 Snap in transmission lines and slide black retaining clips onto transmission line fittings. Do this for both passenger and driver side.

Check to be sure connection is tight.



Step 15 Check fitment. Adjust as necessary.

Tighten all hardware.

*Step 16 Start engine. Check fluid level. Fill as needed.
Check for leaks.
Install bumper, grill and cover.*

Installation complete.