

### BOAT TRAILER WINCH

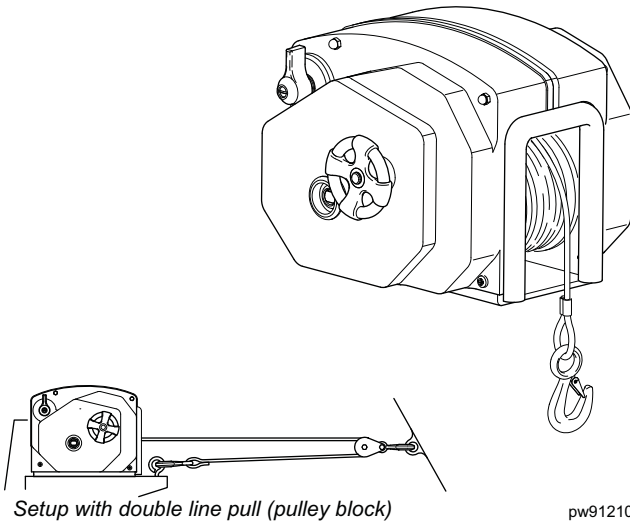

- ◆ 12 Volt Powered Winch
- ◆ Power-In/Free-Wheel Out Operation

# PROPRIETARY STATEMENT

The *Powerwinch* Trailer Winch is a product of Carefree of Colorado, located in Broomfield, Colorado, USA. The information contained in or disclosed in this document is considered proprietary to Carefree of Colorado. Every effort has been made to ensure that the information presented in the document is accurate and complete. However, Carefree of Colorado assumes no liability for errors or for any damages that result from the use of this document.

The information contained in this manual pertains to the current configuration of the models listed on the title page. Earlier model configurations may differ from the information given. Carefree of Colorado reserves the right to cancel, change, alter or add any parts and assemblies, described in this manual, without prior notice.

Carefree of Colorado agrees to allow the reproduction of this document for use with Carefree of Colorado products only. Any other reproduction or translation of this document in whole or part is strictly prohibited without prior written approval from Carefree of Colorado.

# TABLE OF CONTENTS

<b>Safety Information</b> .....	<b>1</b>
General Safety Information .....	1
<b>Specifications</b> .....	<b>2</b>
Winch Specifications.....	2
Approximate Rolling Load Capacities (values are in pounds) .....	2
Winch & Boat Capacities (values are in pounds) .....	2
<b>Mounting the Unit</b> .....	<b>3</b>
Mounting the Unit .....	3
<b>Wiring the Unit</b> .....	<b>4</b>
<b>Pulley Block</b> .....	<b>5</b>
Assembly Instructions: .....	5
Double Lining the Winch .....	5
<b>Operating the Winch</b> .....	<b>6</b>
Unloading The Boat.....	6
Loading the Boat .....	6
Emergency Hand Crank .....	7
<b>Maintenance</b> .....	<b>8</b>
Lubrication.....	8
Replacing the Cable .....	8
Troubleshooting Guide.....	9
<b>Replacement Parts List</b> .....	<b>10</b>
<b>Warranty</b> .....	<b>12</b>

---

## SAFETY INFORMATION

---

**⚠ WARNING** A WARNING INDICATES A POTENTIALLY HAZARDOUS SITUATION THAT, IF NOT AVOIDED, COULD RESULT IN DEATH OR SERIOUS INJURY AND/OR MAJOR PROPERTY DAMAGE.

---

**⚠ CAUTION** A CAUTION INDICATES A POTENTIALLY HAZARDOUS SITUATION THAT MAY CAUSE MINOR TO MODERATE PERSONAL INJURY AND/OR PROPERTY DAMAGE. IT MAY ALSO BE USED TO ALERT AGAINST UNSAFE PRACTICES.

**NOTE:** A note indicates further information about a product, part, or step.

*Tip:* A tip provides helpful suggestions.

### GENERAL SAFETY INFORMATION

**The following Safety Precautions Must be followed at ALL Times**

**Failure to follow the warnings and cautions in this manual could result in serious injury and/or property damage.**

Thoroughly read the manuals furnished with this product and be familiar with the controls. Do not allow individuals to operate the winch without understanding the safe operation and procedures for the equipment.

---

## ⚠ WARNINGS

- ⚠** ALWAYS unplug the wiring harness before attempting to install, relocate, service or perform maintenance on the unit.
- ⚠** NEVER use the winch to lift or move people or animals.
- ⚠** NEVER use the winch for overhead lifting.
- ⚠** NEVER attempt to pull a load greater than the rated load of the winch.
- ⚠** NEVER use the winch to exclusively hold, support or permanently secure the load. Use separate straps to support the load.
- ⚠** ALWAYS stand away from the winch during operation. ALWAYS stand clear of the area behind and between the load and the winch. Serious injury could occur if the cable breaks.
- ⚠** ALWAYS keep hands clear of the cable spool (drum area).
- ⚠** ALWAYS wear leather gloves when handling the cable.
- ⚠** NEVER wear loose fitting clothes, scarves, ties or jewelry when operating the winch. Loose clothing can become caught in moving parts.
- ⚠** ALWAYS use the recommended cable. Never substitute rope for cable.
- ⚠** ALWAYS block the vehicle wheels to help prevent the vehicle from moving when pulling a load with the winch.

**SPECIFICATIONS**

Various load conditions affect winch performance. The line pull required for a specific application depends on the weight of the load, condition of the trailer rollers, and the degree of the loading ramp incline. The charts below are based on a single line pull and provided as a guideline in calculating pulling capabilities.

**⚠ WARNING THE CABLE FASTENERS ON THIS OR ANY WINCH ARE NOT DESIGNED TO HOLD RATED LOADS INDEPENDENTLY. ALWAYS LEAVE A MINIMUM OF FIVE WRAPS OF CABLE ON THE DRUM TO ACHIEVE THE RATED LOAD VALUES.**

*Winch Specifications*

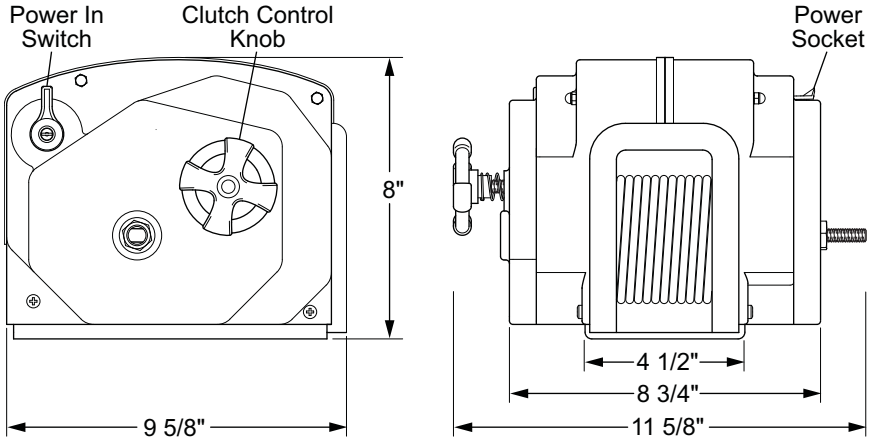

PW912001

Model	Line Speed @ Capacity (FPM)	Gear Ratio	Voltage	Circuit Breaker	Unit Weight
712	14	225:1	12VDC	60 amps	34 lbs.
912	8	450:1	12	60 amps	39 lbs.

*Approximate Rolling Load Capacities (values are in pounds)*

% Incline	Level	5%	10%	20%	30%	50%	70%	100%
° Incline	0°	3°	6°	11°	17°	26°	35°	45°
712	24000	13340	10040	6800	5220	3720	3060	2580
912	40000	23345	17570	11900	9135	6510	5355	4515

- A 10% incline (6°) is 1 foot rise in 10 feet.
- To convert from pounds (lbs) to kilograms (kgs) divide by 2.2.
- Capacity can be increased by using a pulley block.

*Winch & Boat Capacities (values are in pounds)*

	Vertical Lift Capacity	Double Line Pull	Approximate Boat Weight*	Approximate Boat Size*
712	2400	4300	7500	17-23 Feet
912	4000	7500	11500	23-30 Feet

\* Boat size and weight is approximate and varies depending on boat type. When calculating boat weight, use the fully loaded weight that includes boat, motor, fuel, water, gear etc.

## MOUNTING THE UNIT

### MOUNTING THE UNIT

The following instructions are for standard mounting of the winch. A quick mount kit is available (p/n P7700000AJ). If installing with the quick mount kit, follow the directions with the kit. Steps 3, 4 and 6 apply when using the kit.

The winch can be mounted on the trailer in the same position and location as an existing hand winch.

1. Remove the existing hand winch.
2. Position the unit on the trailer mount stand.
3. Confirm that the winch's cable hook and the bow eye on the boat are at the same height when the boat is in the fully loaded position on the trailer.  
If the bow eye is too high, extra pull is required of the winch and extra stress is exerted on the boat's stern and bow eye.  
If necessary to create equal height, raise or lower the winch stand. In most cases, trailer manufacturers have adaptors available for use with a winch.
4. Confirm that there is a minimum of 12 inches clearance between the winch and the bow eye when the boat is in the fully loaded position. If necessary, extend the bow stop to obtain the clearance.
5. Bolt the unit using a minimum of two (2) 3/8" grade 5 machine bolts and lock nuts. If the existing mounting holes do not line up with the winch, use the bottom of the winch as a template and drill two (2) 7/16" holes in the mounting surface of the trailer stand.
6. If using a double line pull (using a pulley block), install a 3/8" eyebolt on the stand as close as possible to the base of the winch. See illustration on page 5.

## WIRING THE UNIT

### ⚠️ WARNINGS

- ⚠️ ALWAYS disconnect the battery before working on electrical equipment.
- ⚠️ ALWAYS use the recommended wire size and rated circuit breakers. Failure to use the furnished and recommended sizes can cause a fire hazard and void warranty.
- ⚠️ When routing the wiring, avoid sources of heat.
- ⚠️ When routing the wiring, avoid sharp edges that can cut or fray the wire insulation.

The following instructions are for permanently wiring the winch. Two additional wiring kits are available and sold separately: A universal bumper wiring kit (p/n P7702101AJ) and a quick connect wiring harness (p/n P7866000AJ) for temporary connections. If installing one of the kits, follow the directions with the kit.

1. Attach the circuit breaker to the battery's POSITIVE (+) post or positive (+) terminal of the starter solenoid.
2. Attach the ground wire (black) to the vehicle frame. Clean the metal frame with a wire brush or equivalent then attach the ground lug using a 5/16" bolt and lock nut (bolt and nut not furnished).
3. Route the wire under the vehicle and along the frame. Avoid sharp edges and moving parts. Secure the wire to the frame approximately every 18" using nylon ties or equivalent.

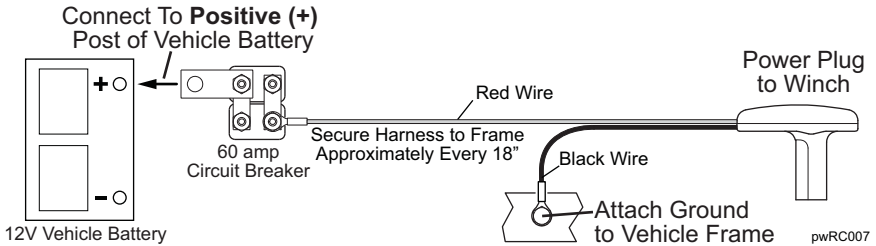

## PULLEY BLOCK

The pulley block can increase the pulling capacity approximately 55%.

### *Assembly Instructions:*

1. Place the two screws through one of the tear drop plates and hold in place.
2. Slide a bushing over each screw.
3. Slide the pulley wheel and hook over the bushings as shown. The components fit loosely on the bushings.
4. Wrap the cable around the pulley.
5. Place the second tear drop plate over the screws and secure using the washers and nuts provided.
6. Mount an eyebolt next to the winch. The eyebolt should be mounted as close to the winch as possible. Eyebolt is furnished by the installer.

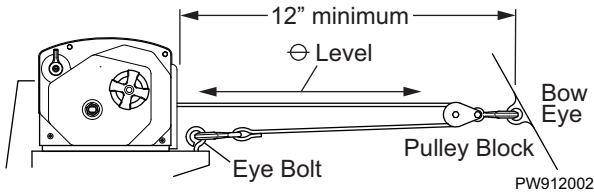
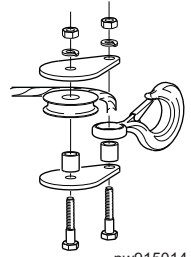

### *Double Lining the Winch*

1. With the cable threaded through the block, hook the pulley block to the eye on the bow.
2. Power out the cable and attach the cable hook to the eyebolt next to the winch.
3. Power in the cable.

## OPERATING THE WINCH

### ! WARNINGS

- ! To avoid personal injury and property damage, clear the area around and behind the boat of people, animals and obstructions before loading or unloading the boat.
- ! Never stand between the load or anchor point and the winch. Serious personal injury could occur if the cable breaks.
- ! ALWAYS wear leather gloves when handling the cable. Steel cable can cause serious damage to hands.
- ! NEVER use the winch alone to secure the boat to the trailer during transit. Use separate straps or equivalent to secure the boat to the trailer.

#### UNLOADING THE BOAT

1. Attach the cable hook to the bow eye on the boat.
2. Connect the power to the winch. The plug goes into the socket on the right side of the winch.
3. Remove the tie down straps from the boat.
4. Slowly turn the clutch knob counterclockwise to release the winch brake.
5. Allow the boat to slide off the trailer. If necessary, the clutch knob can be tightened to slow the speed of the boat.
6. When the boat is in the water, release the cable hook.
7. Tighten the clutch control knob clockwise until finger tight to set the brake.
8. While maintaining tension in the cable, press the switch on the winch. Roll the cable up completely. DO NOT allow the cable to roll up loosely, damage to the cable and winch components could occur.

Power In Switch

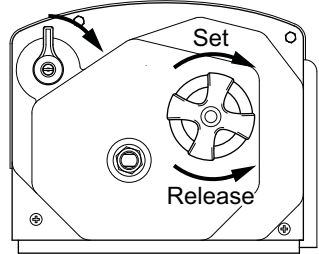

PW912003

! CAUTION Do not allow the cable hook to roll into the winch. Damage to the level wind plate can occur.

9. Secure the cable hook to prevent any accidental injury or damage.

#### LOADING THE BOAT

1. Align the boat and trailer.
2. Loosen the clutch knob (turn counterclockwise) and free-wheel the cable to the boat. Attach the hook to the eye on the bolt.

**NOTE:** If the winch cable is initially difficult to pull out, try engaging the motor for a few seconds with the clutch fully released. This should free the clutch allowing the cable to pull out.

3. Tighten the clutch control knob clockwise until finger tight to set the brake. DO NOT over tighten the clutch knob; over tightening can cause damage to the clutch.
4. Step clear of the cable and boat.
5. Press and hold the switch. Power in the cable until the boat touches the bow stop. Release the button.
6. When fully loaded, secure the boat to the trailer.



## EMERGENCY HAND CRANK

An emergency hand crank is available when there is no power (i.e. a dead battery).

**⚠ WARNING NEVER USE THE HAND CRANK TO ASSIST A RUNNING MOTOR. SERIOUS PERSONAL INJURY CAN OCCUR.**

1. Disconnect the power cord from the winch.
2. Tighten the clutch control knob clockwise until finger tight to set the brake. DO NOT over tighten the clutch knob; over tightening can cause damage to the clutch.
3. Remove the jam nut from the shaft on the right side of the winch.
4. Place the emergency handle onto the shaft and secure to the shaft with the nut removed previously. Tighten the nut snugly against the handle.
5. Turn the crank handle to wind in the cable.  
(Clockwise for 912, counterclockwise for 712.)
6. After the boat has been secured on the trailer, remove the handle from the shaft. Replace the nut on the shaft.
7. Store the handle.

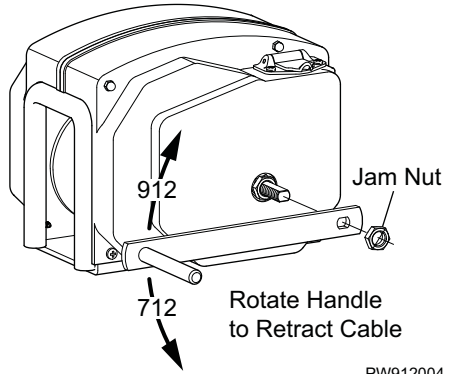

## MAINTENANCE

### LUBRICATION

The following steps should be performed a minimum of once a year or when the unit is placed in storage.

**Cable:** Lubricate the cable with Whitmore's Wire Rope Spray, WD40 or equivalent. Spray the shaft and the cable as the cable is being wound.

**Gears:** Remove the covers and lubricate the gears with lithium base grease. Be careful not to get grease on the clutch lining (refer to figure on page 10).

### REPLACING THE CABLE

**⚠ WARNING ALWAYS USE THE EXACT POWERWINCH REPLACEMENT CABLE (P/N P7188800AJ). WINCH RATING AND CABLE STRENGTH ARE MATCHED FOR SAFE AND OPTIMUM PERFORMANCE. NEVER REPLACE THE CABLE WITH ROPE.**

**⚠ CAUTION ALWAYS wear leather gloves when handling the cable. Steel cable can cause serious damage to hands.**

1. Disconnect the power cable.
2. Loosen the clutch knob (turn counterclockwise) and free-wheel the cable completely out.
3. Cut the old cable off approximately 2" from the cable drum.
4. Slide the collar away from the cable then push the old cable out of the drum shaft.
5. Insert the new cable through the shaft. The cable must be inserted through the side opposite the counter bore.
6. Insert the stop sleeve over the end of the cable until the cable is flush with the end of the stop. Solder or crimp the stop onto the cable.
7. Pull the cable back through the shaft until the stop is seated in the counter bore of hole.
8. Slide the collar around the cable. The notch on the collar fits around the cable.
9. Tighten the clutch control knob clockwise until finger tight to set the brake. DO NOT over tighten the clutch knob; over tightening can cause damage to the clutch.
10. Reconnect the power harness to the unit. Power-in the cable, keeping tension on the cable as it is winding. The cable must wind from the top of the cable spool.

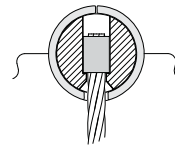
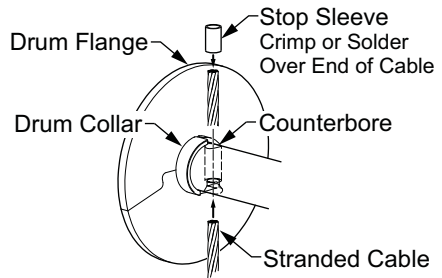

Completed Installation pwRC013

**⚠ CAUTION If the cable is not wound correctly, it may cause loss of power and risk damage to the level wind plate. If the cable is not correct (too loose or wound on one side), unwind the cable then rewind while keeping tension on the cable.**

TROUBLESHOOTING GUIDE

WINCH DOES NOT OPERATE						
A.	<p>Confirm power to winch</p> <ol style="list-style-type: none"> <li>1. Check that vehicle battery is fully charged.</li> <li>2. Confirm connections are for tight &amp; clean.</li> <li>3. Check wires that are worn or bare that may cause shorts.</li> </ol>	<p>Correct as required.</p>				
B.	<p>Check circuit breaker at battery</p> <p>Bypass circuit breaker and test winch. Does the winch run?</p> <p><b>⚠ CAUTION</b> Do not operate the winch without the circuit breaker. Removing the CB from the circuit is ONLY for testing.</p>	<table border="1"> <tr> <td>YES</td> <td>If winch runs, circuit breaker is bad, replace.</td> </tr> <tr> <td>NO</td> <td>Reconnect circuit breaker. Contact your authorized service center.</td> </tr> </table>	YES	If winch runs, circuit breaker is bad, replace.	NO	Reconnect circuit breaker. Contact your authorized service center.
YES	If winch runs, circuit breaker is bad, replace.					
NO	Reconnect circuit breaker. Contact your authorized service center.					
LOAD SLIPS						
A.	Load slips during retrieval	Thrust washers and thrust bearings are worn or deformed. Replace				
B.	Load slips back after boat is retrieved	Clutch bearing inside the 120 gear has failed. Replace gear assembly				
C.	<p>Check clutch lining</p> <p>The clutch lining is located on the 120 tooth gear under the LH (clutch side) of the case. Ensure that the clutch is clean free of grease.</p>	Clean as required. If clutch lining is worn or damaged, replace the 120 tooth gear assy.				
CABLE DIFFICULT TO PULL OUT						
A.	If the winch cable is initially difficult to pull out, try engaging the motor for a few seconds with the clutch fully released. This should free the clutch allowing the cable to pull out.					

REPLACEMENT PARTS LIST

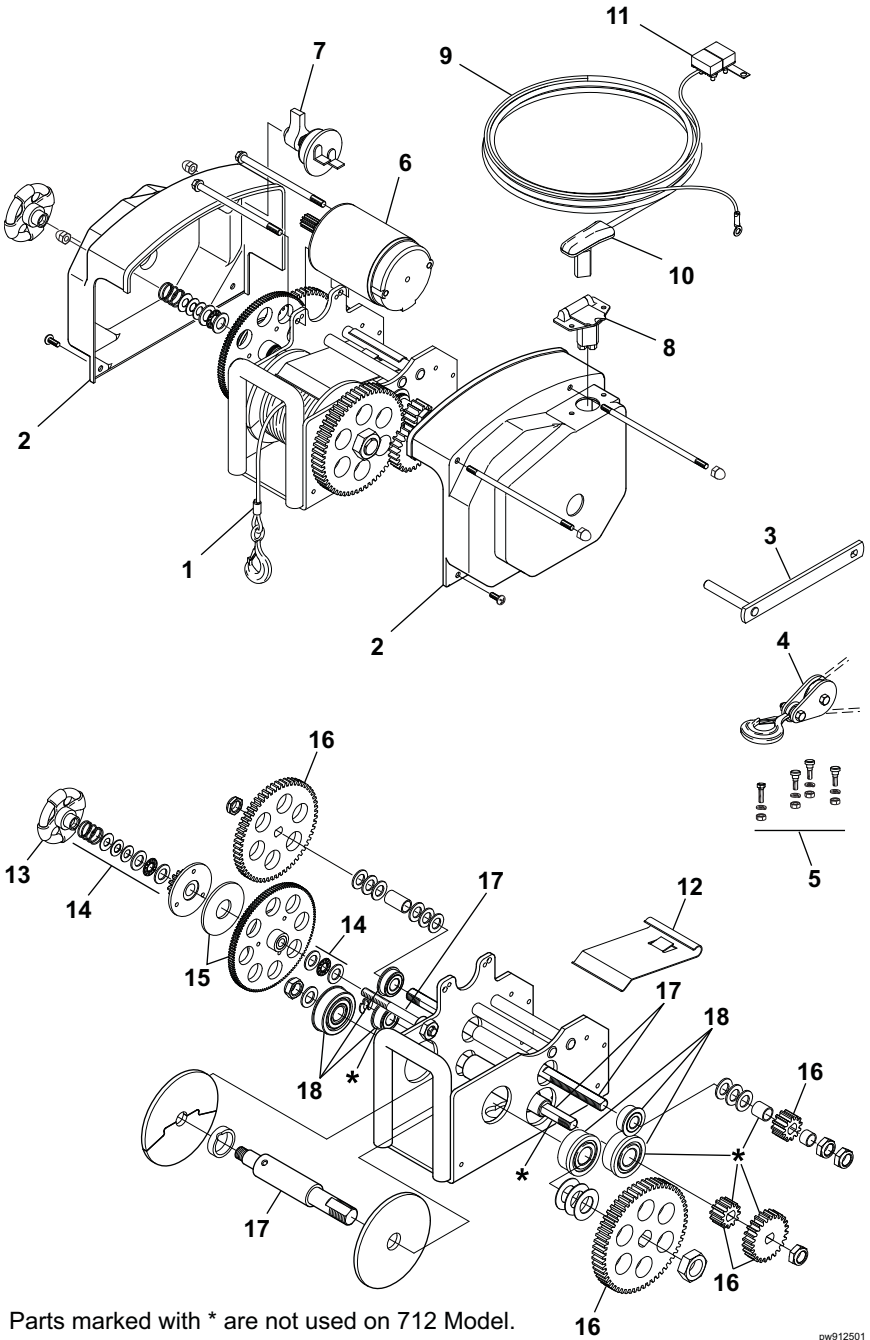

Parts marked with \* are not used on 712 Model.

pw912501

Item	712	912	Description	Notes
1	P7188800AJ	P7188800AJ	Cable Assy, 7/32" x 40'	
2	R001284	R001292	Cover Kit	1
3	P5594700AJ	P5594700AJ	Emergency Hand Crank	
4	P7904300AJ	P7904300AJ	Pulley Block Kit	
5	P7700000AJ	P7700000AJ	Quick Mount Kit	
6	R001287	R001295	Motor Assy	
7	P7811700AJ	P7811700AJ	Switch	
8	P7810300AJ	P7810300AJ	Socket, Power	1
9	P7830201AJ	P7830201AJ	Wire Harness w/ items 6 & 7	
10	P7810500AJ	P7810500AJ	Plug, Wire Harness	
11	P7837300AJ	P7837300AJ	Circuit Breaker, 60amp	
12	R001275	R001275	Level Wind Plate	
13	R001314	R001314	Clutch Knob	
14	P7160901AJ	P7160901AJ	Clutch Spring and Washer Kit	
15	R001283	R001291	120T Gear Kit	
16	R001282	R001290	Gear Kit	
17	R001285	R001293	Shaft Kit	
18	R001281	R001289	Bearing Kit	
19	R001286	R001294	Fastener Kit	
	The following repair kits are also available			
20	P91007	P91007	Drum Shaft and Gear Kit	3
21	n/a	P91008	Intermediate Shaft and Gear Kit	3
22	P91010	P91009	Rear Shaft and Gear Kit	3

- Notes
1. Fasteners are included with kit.
  2. Fasteners and washers not index on illustration are part of the fastener kit (item 19).
  3. The shaft and gear kits (items 20,21,22) contain the respective shaft, gears, bearings and associated hardware

## WARRANTY

Carefree of Colorado (hereafter referred to as Carefree) warrants to the FIRST retail Purchaser that the Powerwinch Product described in this manual is free of defects in material and workmanship within the terms and conditions as set forth below. Carefree's obligation under this warranty is limited to the repair or replacement, at Carefree's option, of any defective component within the stated warranty period. THIS WARRANTY IS NOT TRANSFERABLE.

### 1. DURATION

- a) 1 year on parts and labor.
- b) Carefree will pay the transportation charges for return shipment to the purchaser of any product received for legitimate warranty repair.

Warranty duration is not extended by the length of time the product is not in use or the time that the purchaser is deprived the use of the product. The duration of coverage is determined by the date of the original product purchase, not the date of repairs.

### 2. WHAT IS COVERED UNDER THIS WARRANTY

Defects in the manufacturer's material and workmanship of product under normal use, and which occur within the duration of the warranty period.

### 3. WHAT IS NOT COVERED UNDER THIS WARRANTY

- a) Improper installation and/or any consequent damage or failure that results from improper installation of the product.
- b) Normal wear.
- c) Conditions that are not related to the material or workmanship of the product: including any failure that results from an accident, wind, rain, or other acts of God.
- d) Purchaser's abuse, including but not limited to neglect; failure to operate, use or maintain the product in accordance with the instructions provided with the product.
- e) Any component not sold or manufactured by Carefree.
- f) Any failure that results from the use of another manufacturer's product with a Carefree product that is not specifically approved by Carefree.
- g) Any incidental, indirect, or consequential loss, damage or expense that may result from any defect, failure or malfunction of the product.
- h) The removal or alteration of any product component or device. In the event of such removal or alteration, this warranty is void.
- i) Any expense related to delivery or pick-up of product to/from the service dealer.

### 4. RESPONSIBILITIES OF THE PURCHASER

IN ORDER FOR THE WARRANTY TO BE HONORED, THE PURCHASER MUST HAVE PROOF OF PURCHASE. FAILURE TO PROVIDE THE REQUIRED DOCUMENTATION MAY DELAY OR VOID ANY WARRANTY CLAIM.

- a) Retain dated proof of purchase for the product, and provide it as requested.
- b) Perform "Periodic Maintenance" as specified in Owner's Manual.
- c) Use reasonable care in maintenance, operation, use and storage of the product in accordance with the instructions contained in the owner's manual.

**THIS WARRANTY GIVES THE OWNER SPECIFIC LEGAL RIGHTS. THE LAWS OF CERTAIN JURISDICTIONS MAY GRANT THE OWNER ADDITIONAL RIGHTS AND PRIVILEGES.** Except as set forth above; Carefree makes no warranty, whether statutory or otherwise, including without limitation, any warranty of merchantability or fitness for a particular purpose. Carefree shall have no liability except to repair, replace or adjust defective products and parts. Carefree specifically excludes any liability, whether in contract, tort or otherwise, for personal injury, property damage, economic or consequential losses. Carefree has not authorized any person or company to alter the terms of this warranty.

It is Carefree of Colorado's policy and practice to continuously improve the company's products and services. Therefore, Carefree reserves the right to make changes in design and components, without notice, whenever it is believed the quality of the product will be improved, but without incurring any obligation to incorporate such improvements in any product that has been shipped or in service.