



**NO-
SLIP**

Traction System™

INSTALLATION GUIDE

8221013A

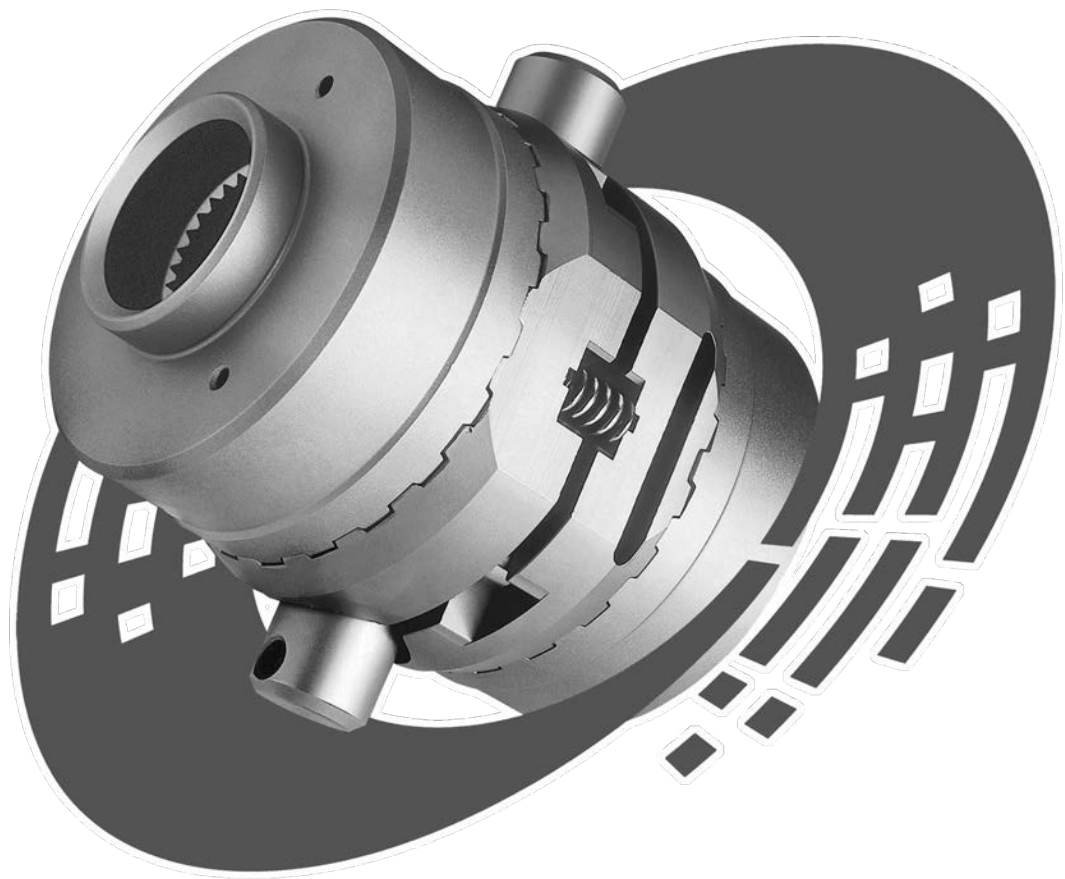



Traction System™

Installation Guide

Contents Page

Open Differential Part Identification & Terminology.....	2
Powertrax No-Slip Differential Exploded View.....	3
Vehicle Preparation for Installation (steps 1 to 5).....	4
Removal of Open Differential Parts (steps 6 to 10).....	5
Preparation of Parts to be Installed (steps 11 to 13).....	7
Assembly (steps 14 to 39).....	8
Verification of Proper Assembly Test (steps 40 to 44).....	17
Finish Installation (steps 45 to 49).....	18

OPEN DIFFERENTIAL

PART IDENTIFICATION/TERMINOLOGY

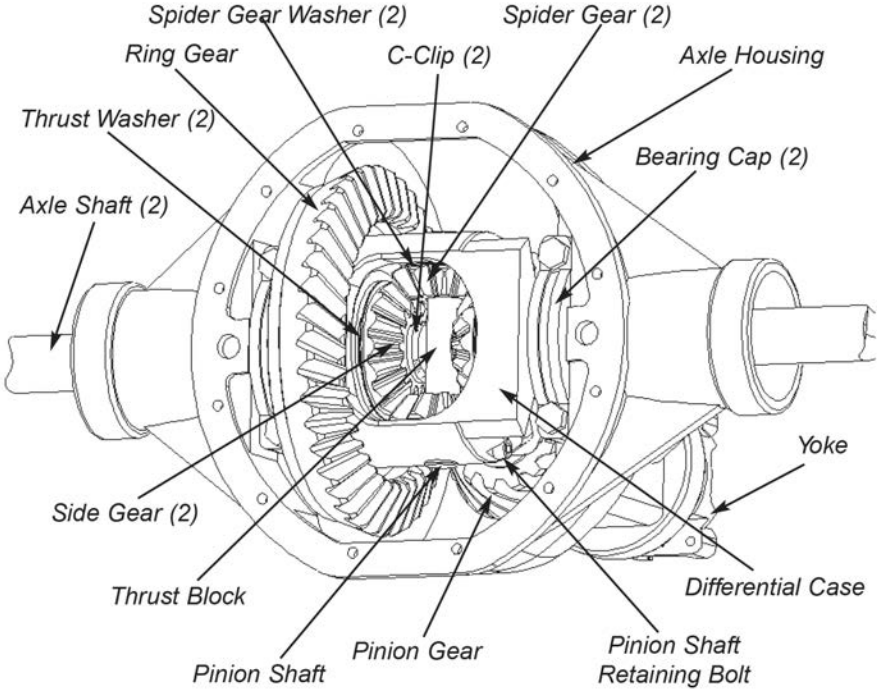

EXPLODED VIEW

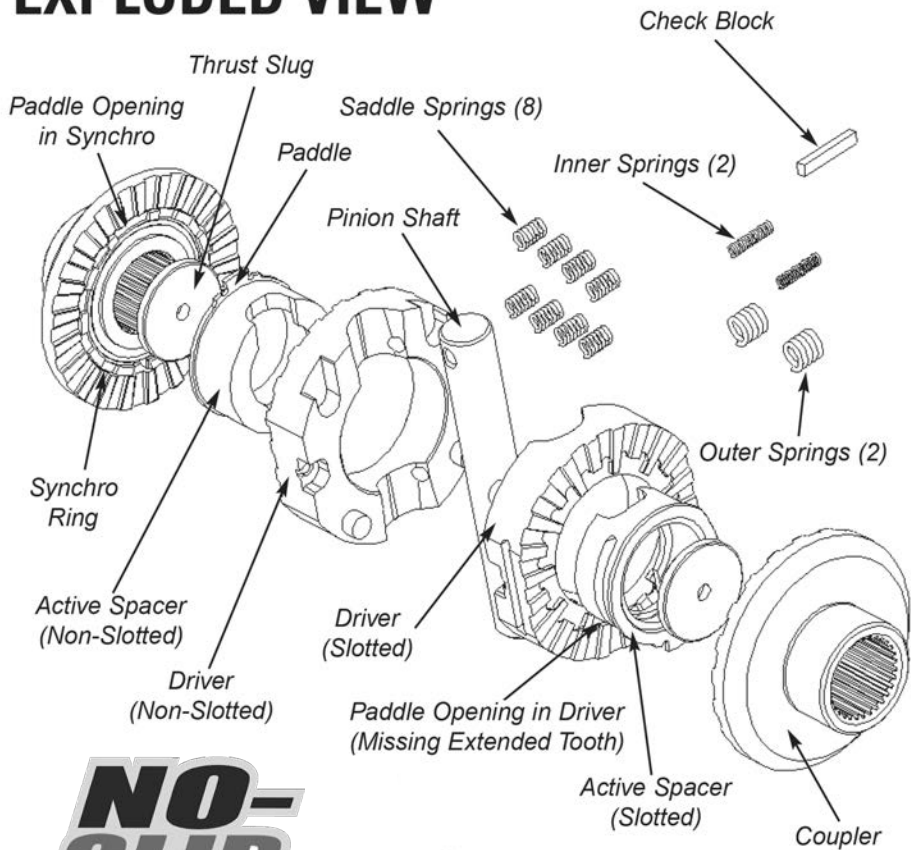

NO-SLIP
Traction System



1. Put transmission in gear (or park), and turn off engine.



2. Set parking brake.



3. Safeguard the vehicle from rolling.



4. Safely raise vehicle and apply jack stands.

5. Put transmission in neutral and release parking brake.



6. Remove Differential cover and drain fluid. Clean the diff cover and housing sealing surface.

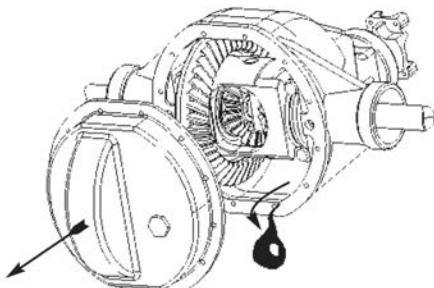

7. Expose pinion shaft;remove retaining bolt and shaft. Remove thrust block.

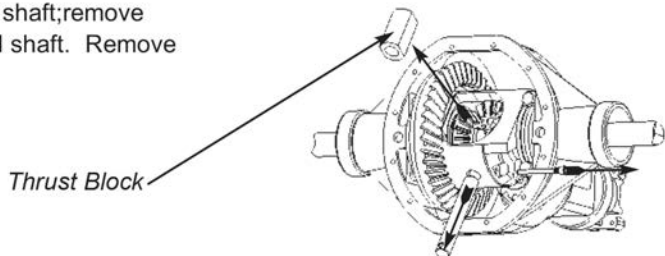

8. Push both axles inward and remove both c-clips. Remove o-rings from c-clip grooves on axle shafts if present.

Note: It may be necessary to remove wheels and disc brake calipers.

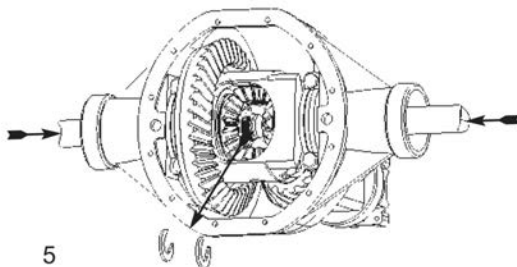

9. Remove both spider gears and their thrust washers.

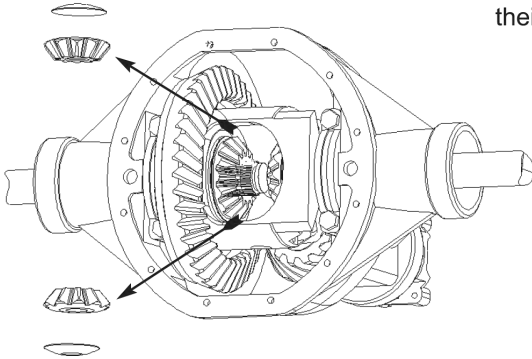

10. Pull axle shafts out approximately 6". Remove side gears and thrust washers.

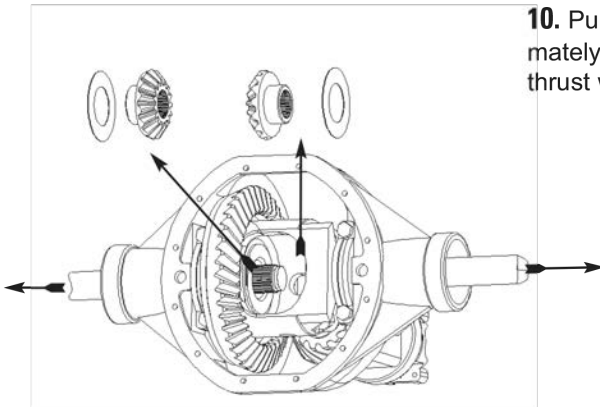

11. Verify gaps in coupler teeth are aligned with gaps in synchro ring. Place coupler in a vise and use an active spacer to align them if necessary.

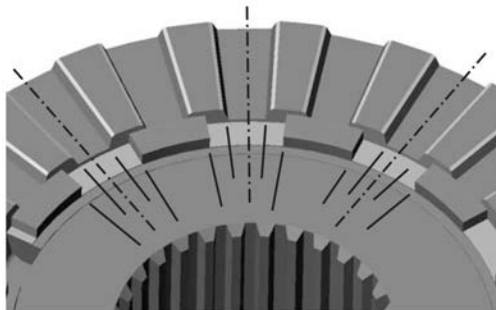

12. Apply wheel bearing grease to driver teeth and spacer.



13. Apply wheel bearing grease to saddle springs and seat in holes.

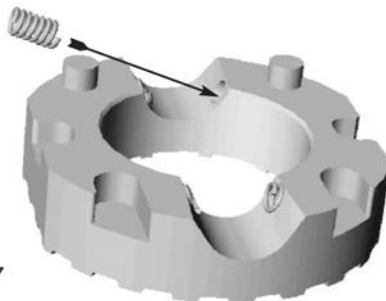

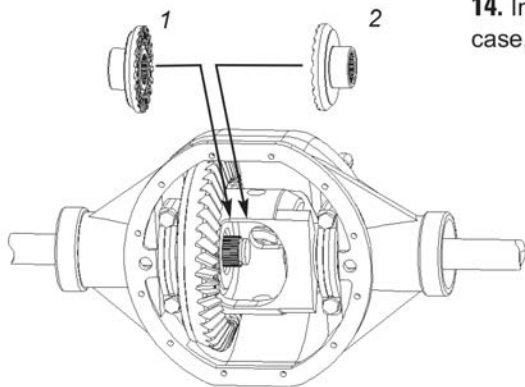

14. Install couplers inside differential case, ring gear side first.

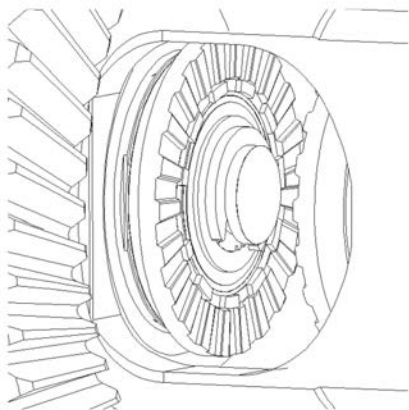

15. Install c-clip on ring gear side axle shaft only.

16. Make sure paddle opening (widest gap) in ring gear side synchro ring is facing out towards you.

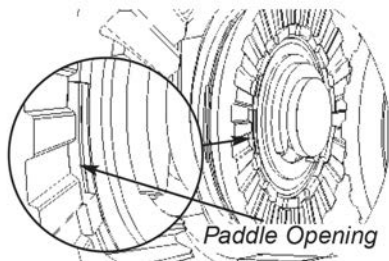

17. Insert the thrust slug into the non-slotted spacer. Insert the non-slotted spacer/thrust slug into the non-slotted driver. Seat the spacer paddle at the paddle opening in driver (missing extended tooth).

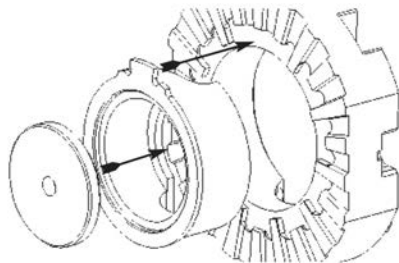

18. Insert driver/spacer as shown, making sure spacer paddle is facing out towards you.

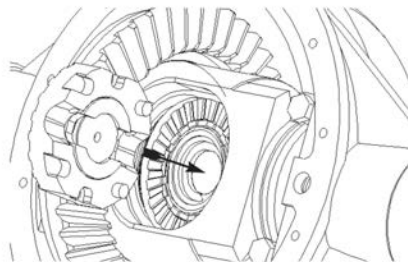

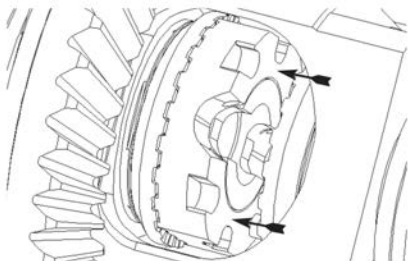

19. Verify spacer paddle is aligned with paddle opening in synchro ring and press driver/spacer down onto coupler. Driver teeth should be fully engaged all the way around.

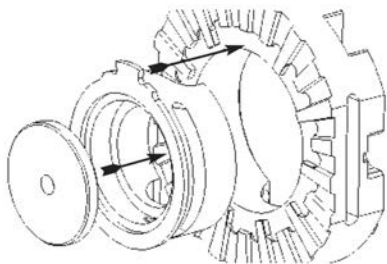

20. Insert the thrust slug into the slotted spacer. Insert the slotted spacer/thrust slug into the slotted driver. Seat the spacer paddle at the paddle opening in driver (missing extended tooth).

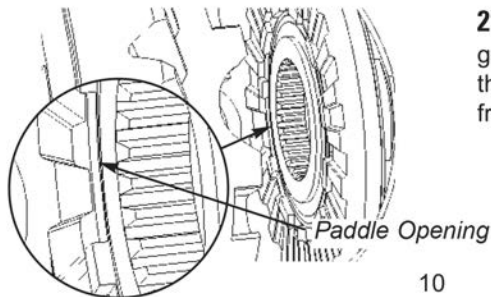

21. Verify paddle opening (widest gap) in other synchro ring is facing the back of the differential, away from you.

22. Install slotted driver/spacer making sure that paddle is pointing away from you toward rear of differential.

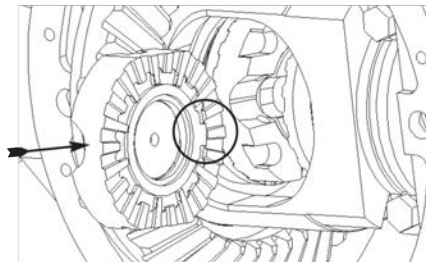

23. Verify spacer paddle is aligned with the paddle opening in synchro ring and press down on driver/spacer to seat on coupler; driver teeth should be fully engaged all the way around.

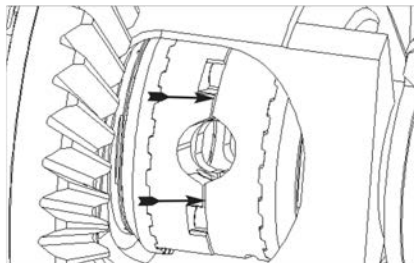

24. Wedge both drivers in engagement with couplers. Rotate driver's side wheel forward 1/4 turn to reveal spring slot.

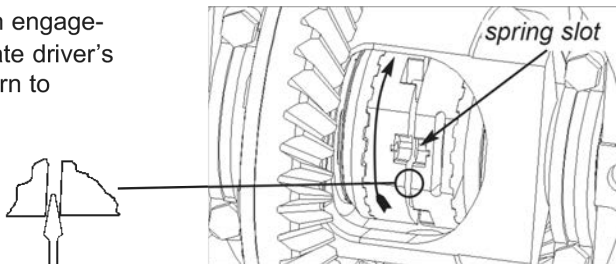



25. Place the two inner springs inside the two outer springs.

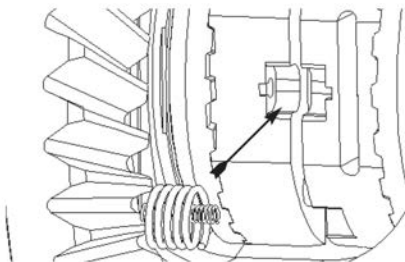

26. Compress inner spring and install spring assembly into spring slot.

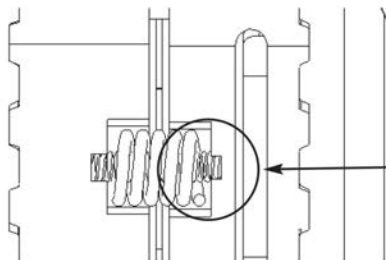

27. Visually inspect notches in spring slot to make sure inner spring is fully seated.

28. Keeping both drivers wedged in engagement with couplers, rotate driver's side wheel forward 1/2 turn to reveal spring slot on other side.

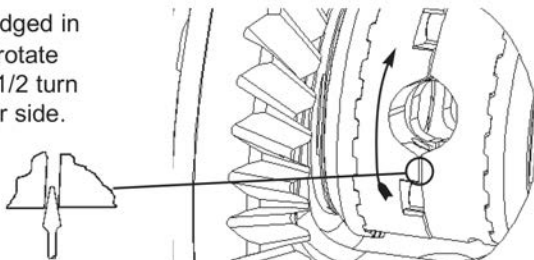

29. Compress inner spring and install the second spring assembly into the second spring slot.

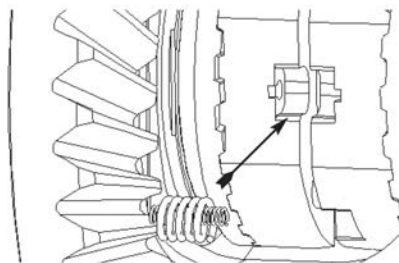

30. Visually inspect notches in spring slot to make sure inner spring is fully seated.

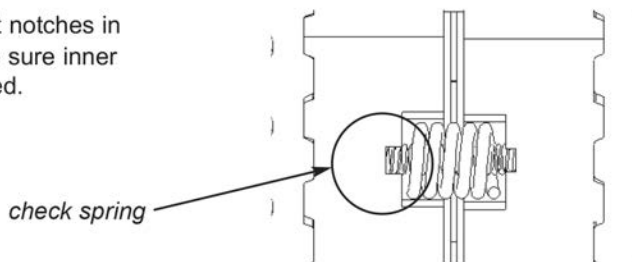

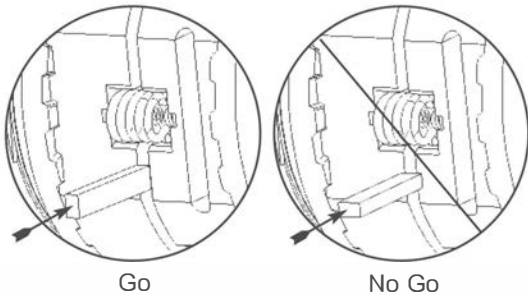

31. Check the gap between drivers using check block. The narrow side of the block should fit between the drivers, but the wider side should not fit.

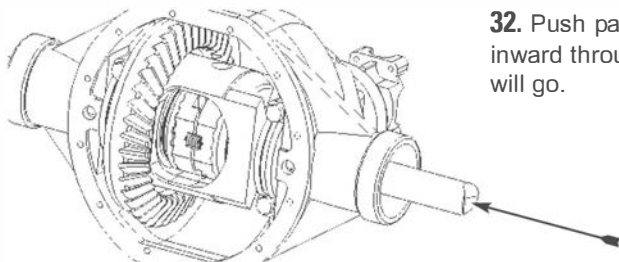

32. Push passenger side axle shaft inward through coupler as far as it will go.

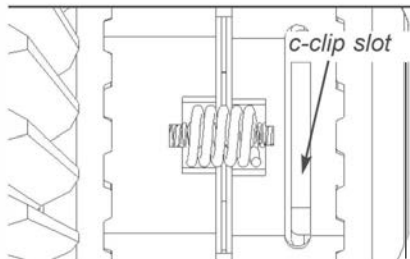

33. Making sure drivers stay engaged with couplers, carefully rotate wheels until c-clip slot is accessible. Verify c-clip groove on axle is accessible through c-clip slots on driver and spacer.

34. Insert 2nd c-clip through c-clip slot in driver onto axle shaft; pull axle shaft out to seat c-clip.

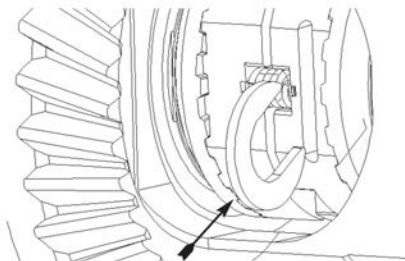

35. Making sure drivers stay engaged with couplers, carefully rotate both wheels backwards 1/4 turn to expose pinion shaft opening.

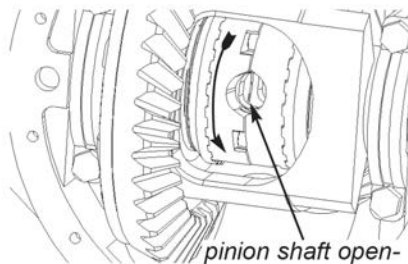

36. Feel through pinion shaft opening and verify both spacers and drivers are fully seated onto couplers. Press down on thrust slugs so that they are seated against the axle ends. Verify all 8 saddle springs are fully seated in holes.

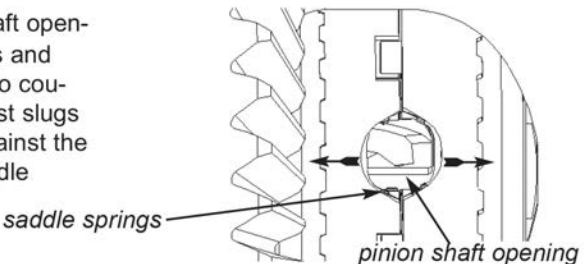

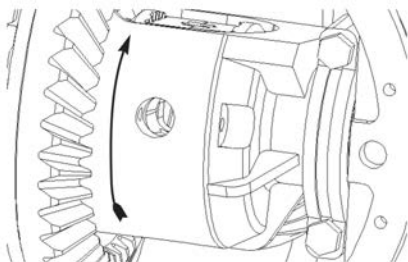

37. Keeping couplers and drivers stationary, rotate case 1/4 turn forward to align pinion shaft opening with driver saddles.

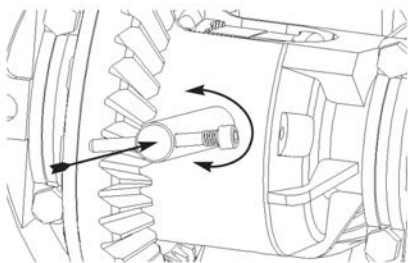

38. Using the retaining bolt as a handle, insert the shaft into the differential. Press hard while twisting to pass shaft by springs.

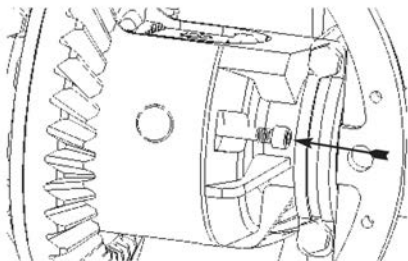

39. Insert retaining bolt into case/shaft. Tighten retaining bolt firmly.



40. Put transmission in gear (or park).

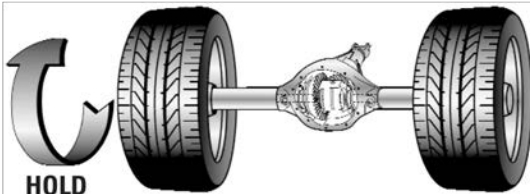

41. Turn driver's side wheel forward and hold against driveline for steps 42 & 43.

42. Passenger side wheel should not be able to rotate in the same direction.

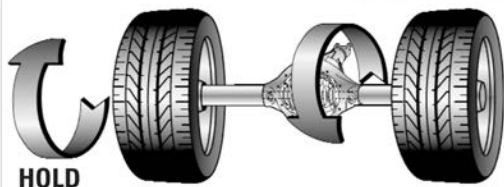
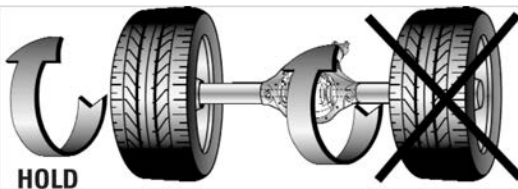

43. After sharply turning the passenger side wheel in the opposite direction (to disengage the unit), the wheel should rotate freely.

44. Repeat the test for both wheels in both directions.

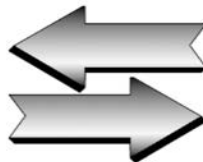



45. Install differential cover with gasket sealant.



46. Add Richmond Synthetic Gear Oil (75W-140) available at your Authorized Richmond Distributor.



47. Set parking brake.



48. Be sure transmission is in gear or park.

49. Remove jack stands, lower vehicle, then remove blocks.

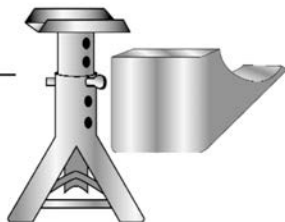

IMPORTANT INFORMATION





WARNING

Please Read Carefully



CAUTION

The following  and  information is supplied to you for your protection and to provide you with many years of trouble free and safe operation of your Richmond Gear product.

Read **ALL** instructions prior to operating transmission and/or ring and pinion. Injury to personnel, transmission or ring and pinion failure may be caused by improper installation, maintenance or operation.



DANGER

- **It is dangerous to get under a jacked-up vehicle.** The vehicle could slip off the jack and fall on you. You could be crushed. Never place any part of your body under a vehicle that is on a jack. Never start or run the engine while the vehicle is on a jack. **If you need to get under a raised vehicle, take it to a service center where it can be raised on a lift.**



WARNING

- Hot oil can cause severe burns. Use extreme care when removing lubrication plugs and when working close to a unit that has been in operation.
- Check lube level between scheduled lube changes to insure that proper lube level is maintained. Inspect vent plug to insure it is clean and operating. Inspect the tightness of mounting bolts, misalignment of connecting shafts, lube leakage, excessive heating, or any unusual noise or vibration.
- Serious personal injury may occur as a result of improperly performed maintenance, adjustments or repairs.
- Do not attempt any of the maintenance, checks or repairs described on the following pages if you are not fully familiar with these or other procedures with respect to the transmission, or are uncertain as to how to proceed. Have the necessary work done by a properly equipped and qualified workshop.
- Always be extremely careful when working on the transmission. Always follow commonly accepted safety practices and general common sense. Never risk personal injury.



CAUTION

- Do not operate the transmission or ring and pinion without proper lube and correct amount.

- For safe operation and to maintain the unit warranty, when changing a factory installed fastener for any reason, it becomes the responsibility of the person making the change to properly account for fastener grade, thread engagement, load, tightening torque and the means of torque retention.
- Mounting bolts should be periodically checked to ensure that the unit is firmly anchored for proper operation.
- These instructions are not intended to cover all details or variations in equipment, nor provide for every possible contingency to be met in connection with selection, installation, operation, and maintenance. Should further information be desired or should particular problems arise which are not covered sufficiently for the Buyer's purpose, the matter should be referred to Richmond Gear.

In the event of the resale of any of the goods, in whatever form, Resellers/Buyers will include the following language in a conspicuous place and in a conspicuous manner in a written agreement covering such sale:

The manufacturer makes no warranties or representations, express or implied, by operation of law or otherwise, as to the merchantability or fitness for a particular purpose of the goods sold hereunder. Buyer acknowledges that it alone has determined that the goods purchased hereunder will suitably meet the requirements of their intended use. In no event will the manufacturer be liable for consequential, incidental or other damages. Even if the repair or replacement remedy shall be deemed to have failed of its essential purpose under Section 2-719 of the Uniform Commercial Code, the manufacturer shall have no liability to Buyer for consequential damages.

Resellers/Buyers agree to also include this entire document including the danger, warnings and cautions above in a conspicuous place and in a conspicuous manner in writing to instruct users on the safe usage of the product.

This information should be read together with all other printed information supplied by Richmond Gear.