

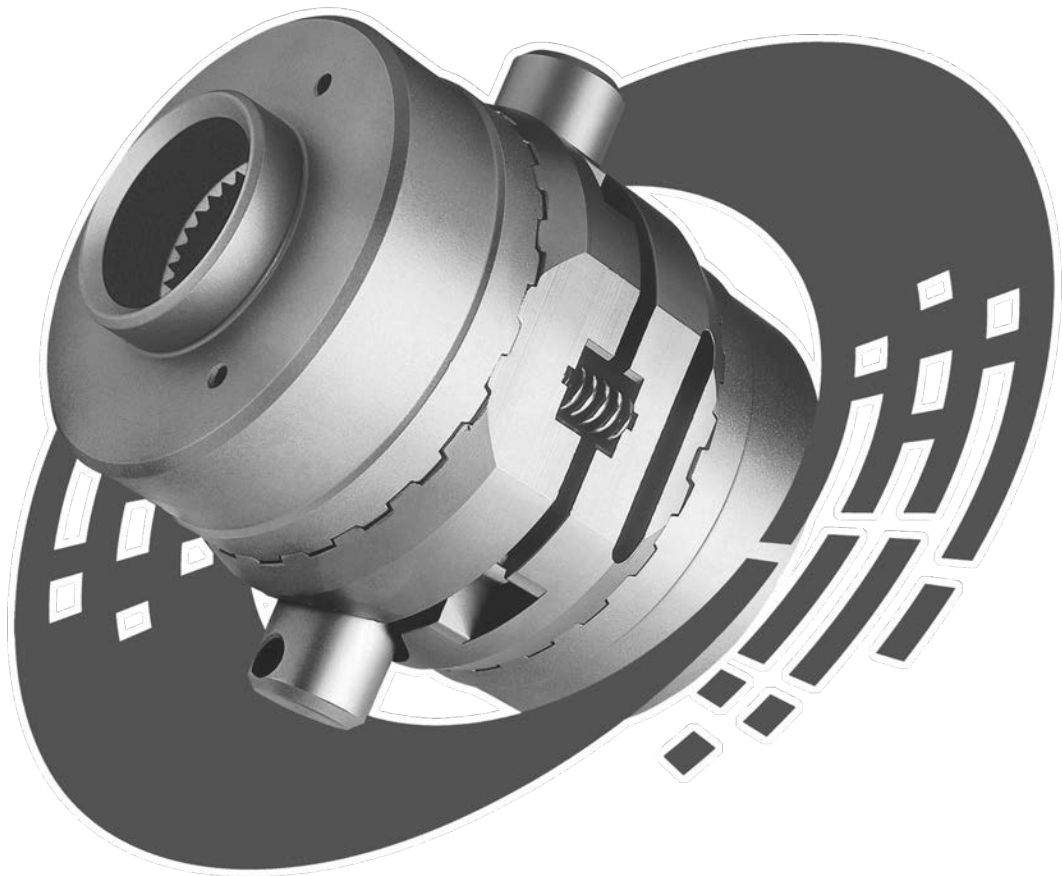

NO-
SLIP
Traction System™

INSTALLATION GUIDE

8221010A





Installation Guide

<u>Contents</u>	<u>Page</u>
Open Differential Part Identification & Terminology.....	2
Powertrax No-Slip Differential Exploded View.....	3
Vehicle Preparation for Installation (steps 1 to 5).....	4
Removal of Open Differential Parts (steps 6 to 16).....	5
Preparation of Parts to be Installed (steps 17 to 19).....	9
Assembly (steps 20 to 36).....	10
Verification of Proper Assembly Test (steps 37 to 41).....	16
Finish Installation (steps 42 to 45).....	17

OPEN DIFFERENTIAL

PART IDENTIFICATION/TERMINOLOGY

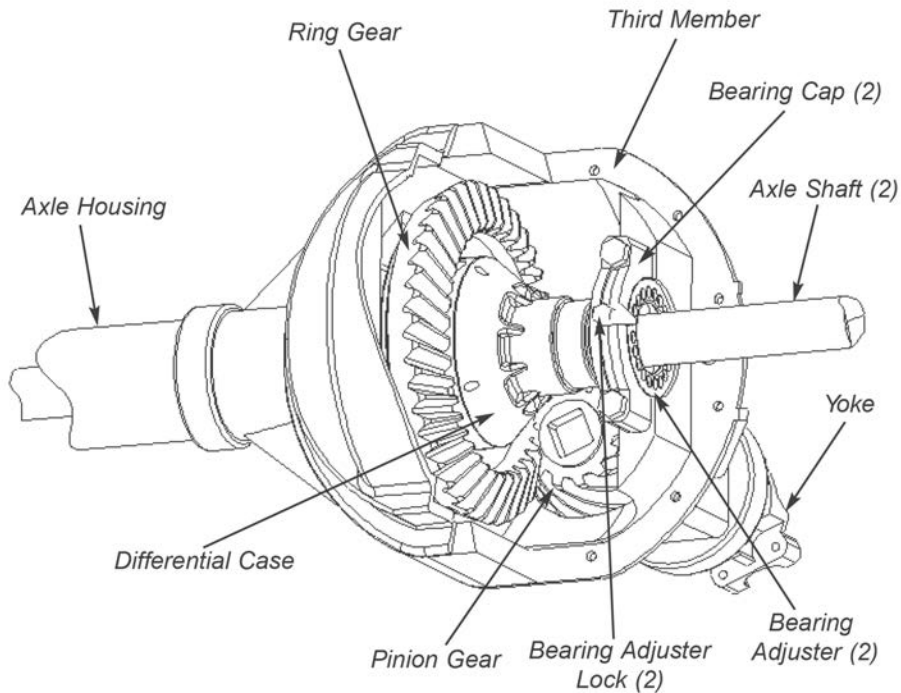

EXPLODED VIEW

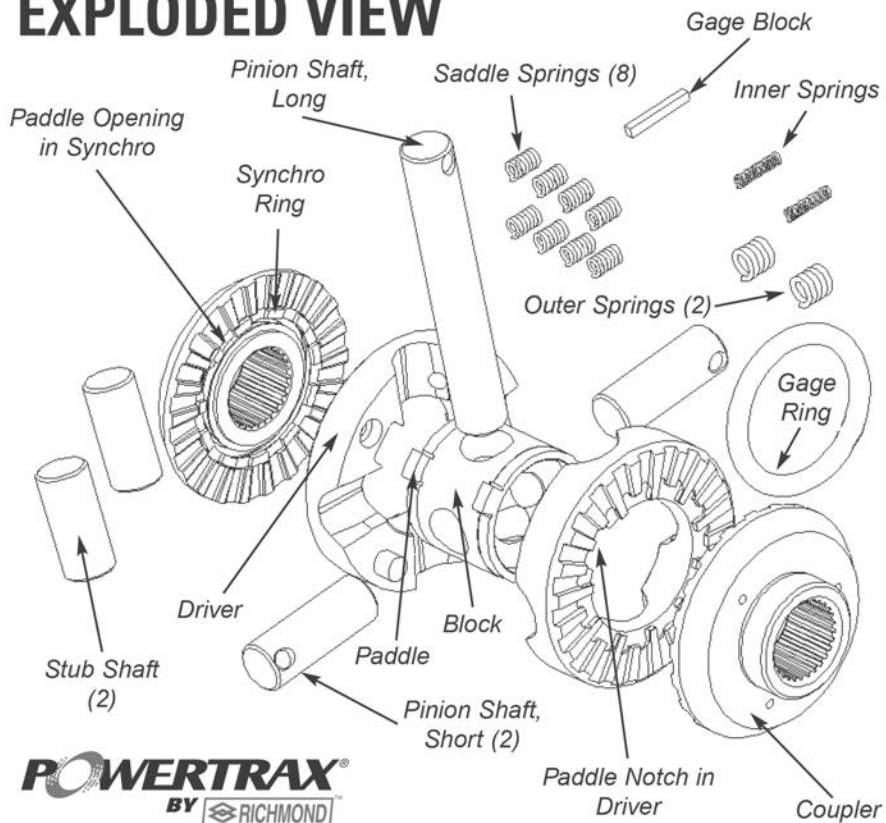



1. Put transmission in gear (or park), and turn off engine.



2. Set parking brake.



3. Safeguard the vehicle from rolling.



4. Safely raise vehicle and apply jack stands.

5. Put transmission in neutral and release parking brake.



6. Remove axle shafts and drive-shaft from axle housing.

Note: In some cases, this may require you to disconnect your brake lines and other items. Please consult your vehicle's repair manual for specific instructions on this step.

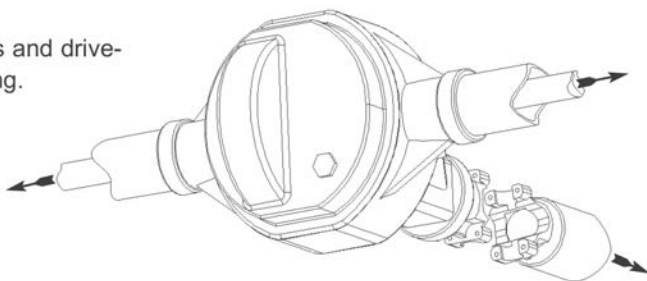

7. Remove complete 3rd member from axle housing.

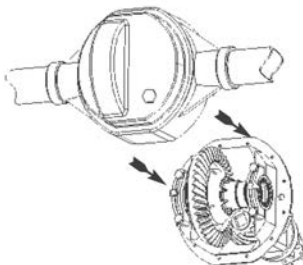

8. Mark the position and orientation of the bearing caps to the third member and bearing adjusters to the adjuster locks. *These parts are not interchangeable and must be reinstalled in their original positions.*

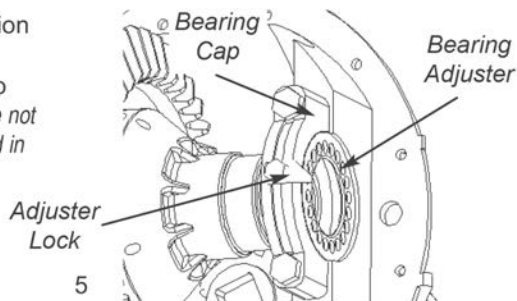

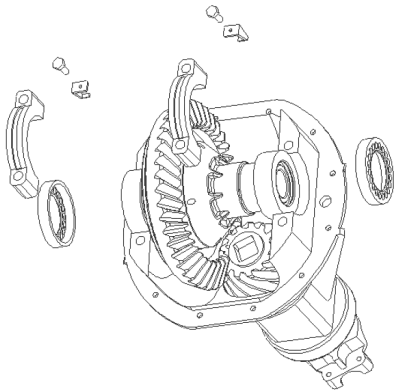

9. Remove adjuster locks, bearing caps, and bearing adjusters from the third member. *These parts should have been marked in Step 8 as they are not interchangeable and must be reinstalled in their original positions.*

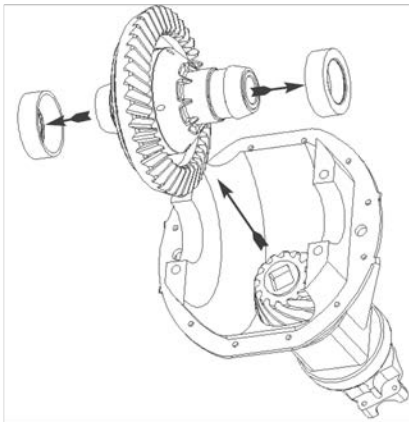

10. Pull out the differential case from the third member. Remove the bearing races from the bearings and mark them. *The bearing races must be reinstalled on the same bearings they were originally on to avoid bearing failure.*

11. Mark the position of the ring gear to the two halves of the differential case and remove the ring gear. *The ring gear must be reinstalled in its original position.*

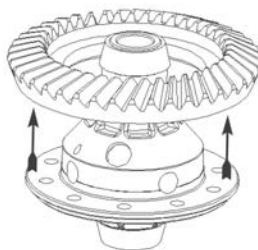

12. Remove the smaller half (cap) of the differential case. *The case halves should have been marked in Step 11 as they must be reinstalled in their original position.*

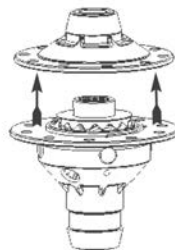

13. Remove the sidegear and thrust washer.

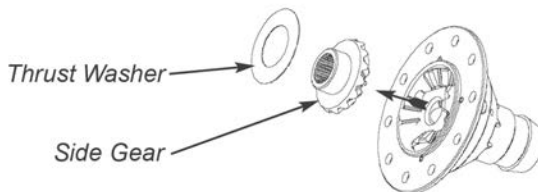

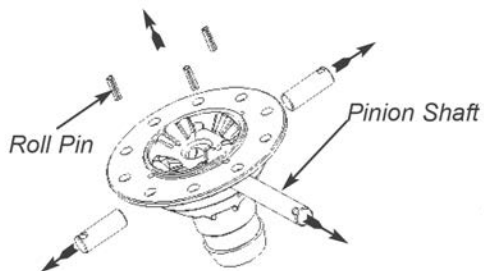

14. Remove roll pins and pinion shafts.

Note: 4-Pinion differential shown. 2-Pinion differentials have only one roll pin and pinion shaft.

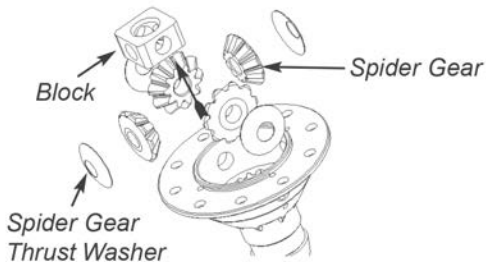

15. Remove spider gears, spider gear thrust washers, and block.

Note: 4-Pinion differential shown. 2-Pinion differentials have only two spider gears and two spider gear thrust washers.

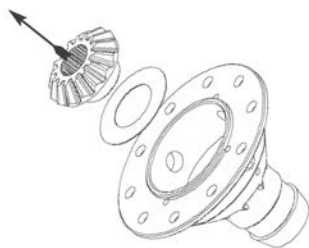

16. Remove the second sidegear and thrust washer.

17. Verify gaps in coupler teeth are aligned with gaps in synchro ring. Place coupler in a vise and use the pinion shaft block to align them if necessary.

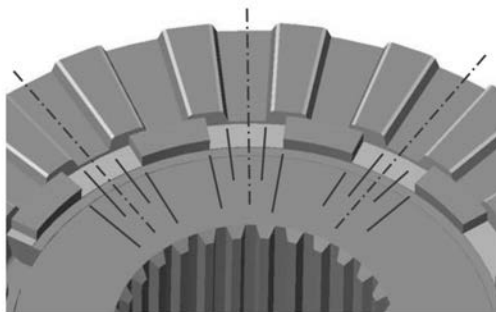

18. Apply wheel bearing grease to driver teeth.



19. Apply wheel bearing grease to saddle springs and seat in holes.

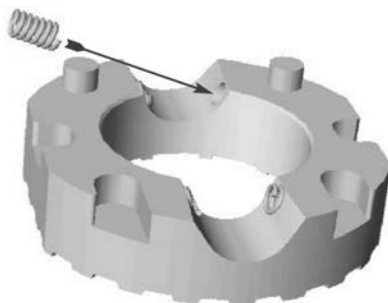

20. Install a coupler into the case.

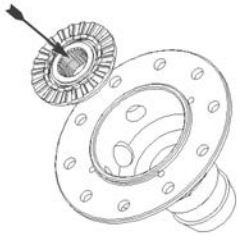

21. Insert the block onto the coupler making sure the block's paddle is aligned with the paddle opening (widest gap) in the synchro ring.

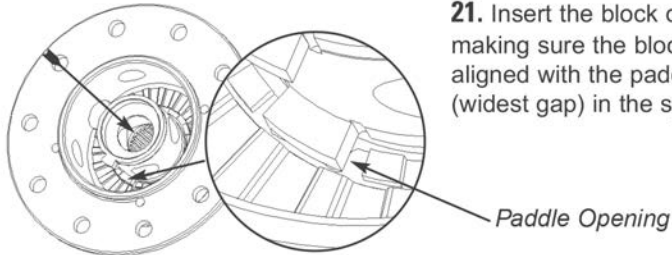

22. Install a driver onto the coupler, making sure the notch in the driver is aligned with the block's paddle. *The driver and coupler teeth should be fully engaged.*

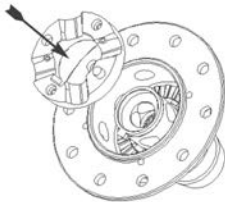

23. In order to check the clearance inside the differential case, temporarily set the second coupler onto the block, and place the gage ring and cap onto the coupler as shown. There should be a gap between the two halves of the differential case.

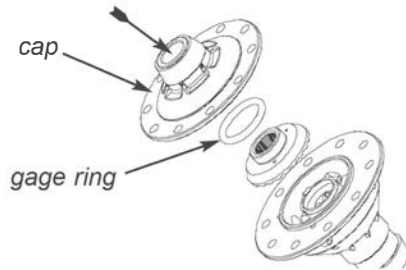

24. Check the gap in the differential case using the gage block. The narrow side of the gage block should fit in the gap, but the wider side should not fit.

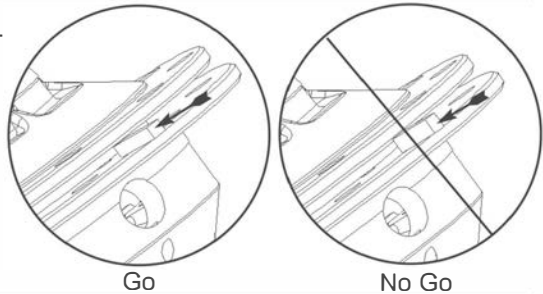

25. If the gap is correct, remove the cap, gage ring, and coupler to proceed.



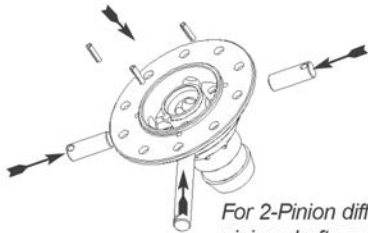

For 2-Pinion differentials, use the two stub shafts instead of the small pinion shafts and install them before inserting the long pinion shaft.

26. Make sure the saddle springs in the driver are in line with the long pinion shaft. Twist the long pinion shaft while pushing it into the case to get it past the saddle springs. Insert the small pinion shafts and drive roll pins into case/shafts.



27. Place the two inner springs inside the two outer springs.



28. Place the two spring assemblies into the spring holes (holes with a step) in the driver.

29. Install the second driver into the differential case making sure the notch in the driver is aligned with the block's paddle.

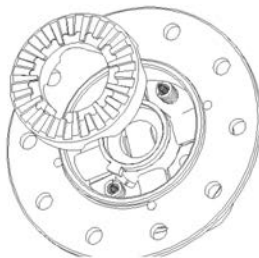

30. Install the second coupler into the differential case. Make sure paddle opening (widest gap) in synchro ring is aligned with the block's paddle. *The driver and coupler teeth should be fully engaged.*

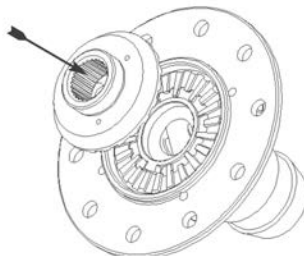

31. Install the cap onto the differential case. *Make sure the two case halves line up to their original positions.*

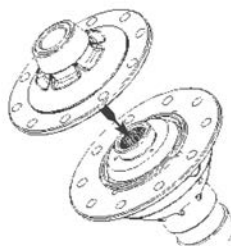

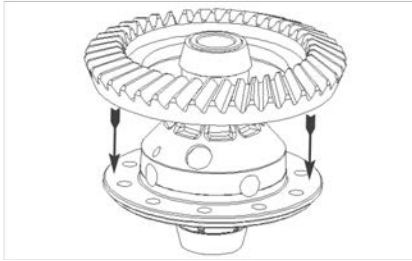

32. Reinstall the ring gear back onto the case. *Make sure the mark on the ring gear lines up with the mark on the two halves of the case.*

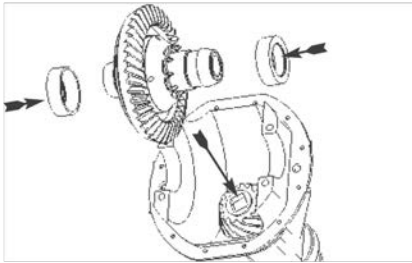

33. Reinstall each bearing race *on its original bearing* and install the assembly in the third member.

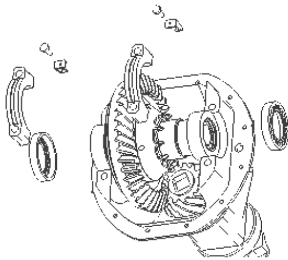

34. Reinstall the bearing caps *in their original positions*. Install the bearing adjusters back *in their original positions*. Tighten bearing caps down to required torque and reinstall bearing adjuster locks.

35. Bolt third member back to housing.

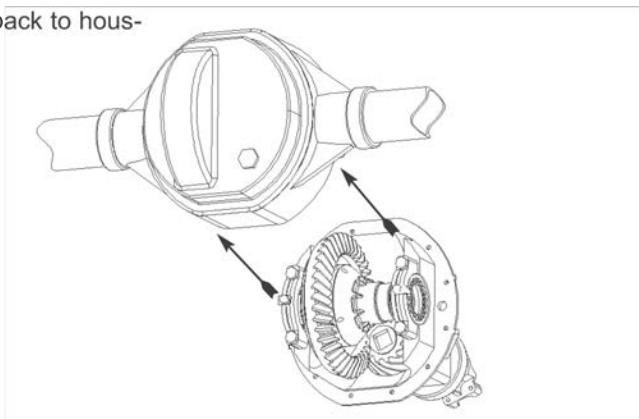

36. Reinstall axle shafts and drive-shaft.

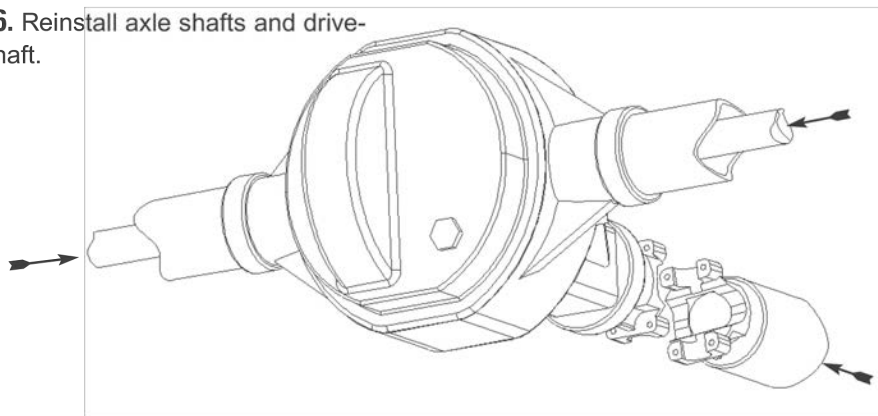



37. Put transmission in gear (or park).

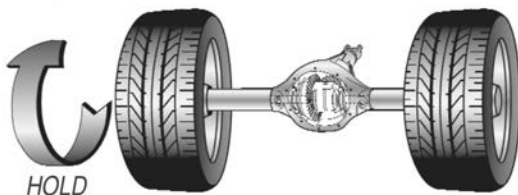

38. Turn driver's side wheel forward and hold against driveline for steps 39 & 40.

39. Passenger side wheel should not be able to rotate in the same direction.

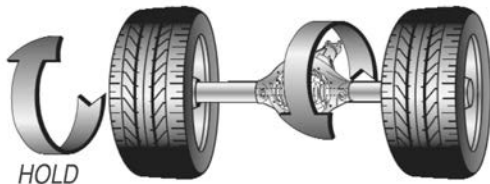
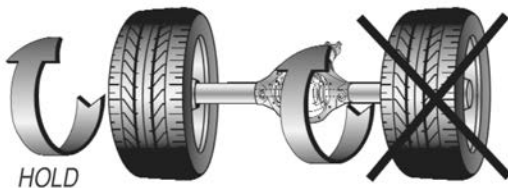

40. After sharply turning the passenger side wheel in the opposite direction (to disengage the unit), the wheel should rotate freely.

41. Repeat the test for both wheels in both directions.

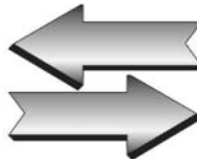



42. Add Richmond Gear Oil (75-140) available at your authorized Richmond Distributor.



43. Set parking brake.



44. Be sure transmission is in gear or park.

45. Remove jack stands, lower vehicle, then remove blocks.

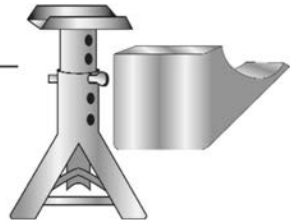



IMPORTANT INFORMATION



Please Read Carefully



The following  and  information is supplied to you for your protection and to provide you with many years of trouble free and safe operation of your Richmond Gear product.

Read **ALL** instructions prior to operating transmission and/or ring and pinion. Injury to personnel, transmission or ring and pinion failure may be caused by improper installation, maintenance or operation.



- **It is dangerous to get under a jacked-up vehicle.** The vehicle could slip off the jack and fall on you. You could be crushed. Never place any part of your body under a vehicle that is on a jack. Never start or run the engine while the vehicle is on a jack. **If you need to get under a raised vehicle, take it to a service center where it can be raised on a lift.**



- Hot oil can cause severe burns. Use extreme care when removing lubrication plugs and when working close to a unit that has been in operation.
- Check lube level between scheduled lube changes to insure that proper lube level is maintained. Inspect vent plug to insure it is clean and operating. Inspect the tightness of mounting bolts, misalignment of connecting shafts, lube leakage, excessive heating, or any unusual noise or vibration.
- Serious personal injury may occur as a result of improperly performed maintenance, adjustments or repairs.
- Do not attempt any of the maintenance, checks or repairs described on the following pages if you are not fully familiar with these or other procedures with respect to the transmission, or are uncertain as to how to proceed. Have the necessary work done by a properly equipped and qualified workshop.
- Always be extremely careful when working on the transmission. Always follow commonly accepted safety practices and general common sense. Never risk personal injury.



- Do not operate the transmission or ring and pinion without proper lube and correct amount.

- For safe operation and to maintain the unit warranty, when changing a factory installed fastener for any reason, it becomes the responsibility of the person making the change to properly account for fastener grade, thread engagement, load, tightening torque and the means of torque retention.
- Mounting bolts should be periodically checked to ensure that the unit is firmly anchored for proper operation.
- These instructions are not intended to cover all details or variations in equipment, nor provide for every possible contingency to be met in connection with selection, installation, operation, and maintenance. Should further information be desired or should particular problems arise which are not covered sufficiently for the Buyer's purpose, the matter should be referred to Richmond Gear.

In the event of the resale of any of the goods, in whatever form, Resellers/Buyers will include the following language in a conspicuous place and in a conspicuous manner in a written agreement covering such sale:

The manufacturer makes no warranties or representations, express or implied, by operation of law or otherwise, as to the merchantability or fitness for a particular purpose of the goods sold hereunder. Buyer acknowledges that it alone has determined that the goods purchased hereunder will suitably meet the requirements of their intended use. In no event will the manufacturer be liable for consequential, incidental or other damages. Even if the repair or replacement remedy shall be deemed to have failed of its essential purpose under Section 2-719 of the Uniform Commercial Code, the manufacturer shall have no liability to Buyer for consequential damages.

Resellers/Buyers agree to also include this entire document including the danger, warnings and cautions above in a conspicuous place and in a conspicuous manner in writing to instruct users on the safe usage of the product.

This information should be read together with all other printed information supplied by Richmond Gear.