

# Flip-Over™

## Installation Instructions

### Model 216 Dodge Classic

Fits 1994- 2001  
Long & Short Bed - 1/2, 3/4 & 1 Ton

Fits 2002  
Long and Short Bed- 3/4 & 1 Ton



## MODEL 216

### FOR THE SAFEST INSTALLATION

**WARNING** Most pick up trucks have **FUEL LINES** and/or **BRAKE LINES** and/or **ELECTRICAL WIRING** positioned along the truck frame rails where your hitch will install. **BEFORE INSTALLATION** identify and examine the location of fuel lines, brake lines and electrical wires. Be sure you will not damage fuel lines, brake lines or electrical wiring when positioning hitch components, drilling holes or tightening fasteners. **Be Certain To Avoid Fuel Tanks When Drilling Holes.**

- Wear Safety Glasses, Gloves and Particle Mask for protection while installing a Flip-Over gooseneck hitch.
- ALWAYS correctly chock tires prior to raising truck with jacking device. For protection in case of jacking device failure ALWAYS use Jack Stands when working under or around a truck which has been raised by a jacking device.
- Be certain the exhaust system is cool prior to installation to avoid possible burns from hot tail pipe and muffler.
- Torque ALL fasteners used in the Flip-Over gooseneck hitch installation as specified in these Installation Instructions.

### INSTALLATION PROCEDURE **NOTE: Does Not Fit 2002 Ram 1500 Trucks (Use Model 219)**

**WARNING: Verify adequate [trailer swing](#) clearance between trailer nose and cab of truck, and trailer and rear of truck.**

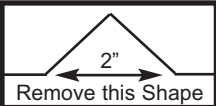
1. Mark and center punch a location for **SHORT BED TRUCKS** at 44" or for **LONG BED TRUCKS** at 48" from the rear lip of the truck bed (tailgate end) centered between the wheel wells. Use a 3-1/2" hole saw to cut a hole in the bed floor centered at this location. Clean all saw tailings from the bed area before proceeding. Remove the spare tire.
2. If so equipped, cut the **Heat Shield** off where it bends upward to pass over the muffler hanger/shock absorber mount, remove the three 3/8" sheet metal screws, and discard the rear section of the heat shield.
3. Some **Short Bed** trucks have sheet metal brackets spot welded outside the frame rails at the bed cross member forward of the axle. It may be necessary to remove these brackets to mount the Frame Plates. It is often possible to distort these brackets sufficiently to install the Frame Plates. (These brackets are used for bed alignment during truck manufacture.)
4. On **Four Wheel Drive** trucks it is necessary to remove the driver side plastic fender liner if so equipped. After hitch installation is complete re-install the fender liner using pop rivets or nuts and bolts (not provided) and cut a hole in the fender liner with the 3 1/2" hole saw to allow access to the Actuating Rod.
5. To install the Cross Members it may be necessary to cut a notch in the lip above the frame where the inner fender and bed floor join. Cut and remove a notch as shown in the illustration 4" ahead of the axle where the hitch will install. Pass the Front Cross Member 1" X 2" bar (2) over the frame with the bar oriented with the threaded holes nearest the bottom side. Center the Cross Member across the frame rails ahead of the hole against the bed floor sill cross member.
6. Slide the Rear Cross Member (1), the angle, across the frame rails similarly, with the plain side (2" leg) up and with the slotted side facing forward. Position the Rear Cross Member about 6" rearward of the 3-1/2" hole in the bed floor.
7. Raise the Center Assembly (3) with the release mechanism facing the driver side into position between the Cross Members, Fasten the front threaded bar to the center section with 1/2" bolts putting washers over oval holes. Position the protruding tube in the channel web into the 3-1/2" hole. Use an overhead lifting device, or a saw horse in the bed of the truck, and cable or rope to hold the Center Assembly firmly against the underside of the bed floor. Insure that the top of the Center Assembly channel is flush with the bottom of the bed floor.

## INSTALLATION PROCEDURE - CONTINUED

8. Slide the Rear Cross Member forward and fasten it to the Center Assembly with 1/2" X 1-1/4" bolts with washers on the slotted holes and 1/2" nuts. Tighten the fittings in the Front Cross Member. Leave the fittings in the Rear Cross Member very loose at this time. Square the assembled Cross Members and Center Assembly across the frame.

9. Identify the driver side Frame Plate (4, with labels) and passenger side Frame Plate (5). Position the Frame Plate extension tabs between the Cross Members. Fasten to the Front Cross Member using a flat washer and 1/2" nut on the bent tang of the Frame Plate. Fasten to the Rear Cross Member by passing a 1/2" X 1-1/4" bolt with a flat washer from the Frame Plate and securing with a flat washer and 1/2" nut. Leave these fittings loose at this time.

**NOTE:** On trucks equipped with **OVERLOAD SPRINGS** it is necessary to cut 3" off of the rearward end of the Frame Plates

10. Fasten the Frame Plates to the frame by aligning two of the the slots in the Frame Plate with existing holes in the truck frame. Pass 1/2" X 1-1/4" bolts with flat washers from inside the frame and secure with 1/2" flat washers and nuts.

11. **Torque** 1/2" fasteners to **65 foot pounds** in the following sequence: First the Cross Members to Center Assembly, then to the Frame Plates to the Cross Members, and finally the Frame Plates to the truck frame.

12. From the driver side, pass the Actuating Rod (6) through the 1/2" hole (NOT the slotted hole) between the Frame Plate extensions and into the linkage coupler. Align the Actuating Rod so the set screw seats in the hole provided in the rod, and tighten to 7 foot pounds. Be certain the Actuating Rod rotates freely and be certain it moves in and out freely.

13. Drill four 1/2" holes for the Safety Chain Brackets from under the truck bed. Drill through the two pairs of holes in the Center Assembly that are **closest to the hitch ball**. Place a U-bolt in each pair of holes from the top side of the bed. From under the bed place a spring and 1/2" nut on each U-bolt leg. Tighten each nut until thread extends through the nut.

14. Retract the Retaining Pin by rotating the Actuating Rod 90 degrees counter clockwise. Place the Flip-Over ball in the Socket. Rotate the Actuating Rod 90 degrees clockwise to engage the Retaining Pin.

15. Keep the base of the Flip-Over ball lightly lubricated with lithium grease. Keep the trailer coupler and the Flip-Over ball lightly lubricated with lithium grease

16. Please read the **SAFE TOWING INSTRUCTIONS** on the Flip-Over WARRANTY sheet.

### HARDWARE PROVIDED

- 16 - 1/2" X 1-1/4" Grd. 8 Bolts
- 14 - 1/2" Lock Nuts
- 14 - 1/2" Flat washers
- 2 - U-Bolts
- 4 - 9/16" X 3" Springs

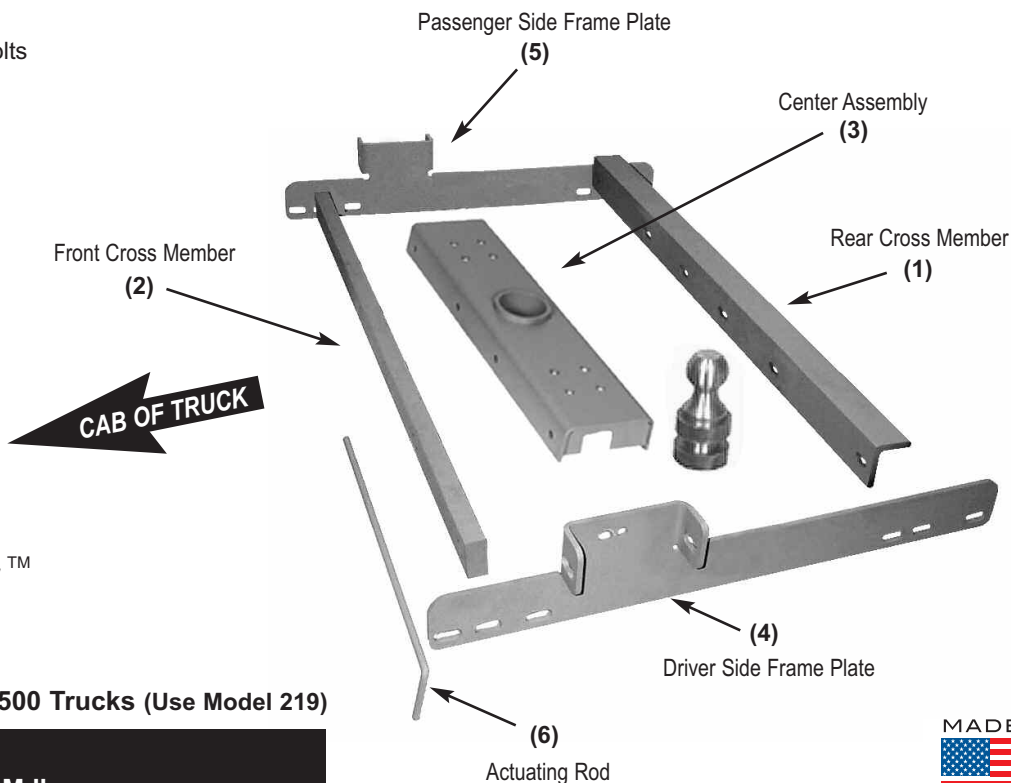

Does Not Fit 2002 Ram 1500 Trucks (Use Model 219)

**Model Number 216**  
**Gross Trailer Weight: 30M lbs.**  
**Gross Trailer Tongue Weight: 7.5M lbs.**

