

Flip-Over™

Installation Instructions

Model 211
Ford Super Duty
Fits 1999 - 2007
Long & Short Bed - 3/4 & 1 Ton
2WD Only



Model 211 11-11 FOR THE SAFEST INSTALLATION

WARNING Most pick up trucks have **FUEL LINES** and/or **BRAKE LINES** and/or **ELECTRICAL WIRING** positioned along the truck frame rails where your Flip-Over hitch will install. **BEFORE INSTALLATION** identify and examine the location of fuel lines, brake lines and electrical wires. Be sure you will not damage fuel lines, brake lines or electrical wiring when positioning the hitch components, drilling holes or tightening fasteners. **Be Certain To Avoid Fuel Tanks When Drilling Holes.**

- Wear Safety Glasses, Gloves and Particle Mask for protection while installing a Flip-Over gooseneck hitch.
- ALWAYS correctly chock tires prior to raising truck with jacking device. For protection in case of jacking device failure ALWAYS use Jack Stands when working under or around a truck which has been raised by a jacking device.
- Be certain the exhaust system is cool prior to installation to avoid possible burns from hot tail pipe and muffler.
- Torque ALL fasteners used in the Flip-Over [gooseneck hitch](#) installation as specified in these Installation Instructions.

INSTALLATION PROCEDURE

WARNING: Verify adequate trailer swing clearance between trailer nose and cab of truck, and trailer and rear of truck.

1. Locating the 3-1/2" Hole in the Truck Bed Floor:

Mark and center punch a location 49-7/8" from the rear lip of the truck bed floor centered between the wheel wells. Use a 3-1/2" hole saw to cut a hole in the bed floor centered at the correct location. File or sand the edges of the hole to remove any burrs. Before proceeding, remove all saw tailings from the bed area.

2. Remove the spare tire. If using a vehicle hoist, raise the truck at this time. If using a jacking device Chock the front tires to prevent the truck from rolling. Jacking against the rear bumper or frame, lift the rear of the truck approximately 10". It is not necessary to lift the rear tires off the ground. Properly position jack stands under the rear frame of the truck to protect against jack failure.

On some Diesel Trucks use the provided bracket and 5/16" X3/4" bolts and nuts to lower the REAR tailpipe hanger 2".

3. The heat shield located above the tail pipe at the rear axle must be removed. Peel off ceramic shields. Replace the forward screws removed on older trucks.

4. Identify the Rear Cross Member (1), the angle with the deepest notches. With the plain side (2" leg) up and with the slotted side (2-1/2") facing the front of the truck, slide the Cross Member across the frame rails from the driver side wheel well forward of the rear axle. Slide the Cross Member rearward onto the highest part of the frame rails. Position the Cross Member approximately square across the frame rails and about 6" behind the hole in the bed floor.

5. Slide the Front Cross Member (2) across the frame rails similarly, with the plain side (2" leg) up and with the slotted side facing rearward. Position the Forward Cross Member about 3" forward of the hole in the bed floor. **NOTE:** The Front Cross Member must be modified for optional 47" 4X4 hole location. Cut the notches in the Front Cross Member as deep as the notches in the Rear Cross Member.

6. Position the Center Assembly (3) between the Cross Members with the pin retractor facing the driver side and inserting the 3-1/2" tube in the hole cut in the bed floor. Secure it to an overhead lifting device or a saw horse in the truck bed to hold it firmly against the underside of the bed floor. Fasten the Center Assembly to the Cross Members with eight 1/2" X 1-1/4" bolts and lock nuts, placing flat washers over the slotted holes. Do not fully tighten at this time.

INSTALLATION PROCEDURE - CONTINUED

- Remove the Emergency Brake Cable Bracket from the frame located on the driver side. Knock the mounting stud out of the frame.
- Square the assembled Cross Members and Center Assembly across the frame. Identify the driver side (4, with labels) and passenger side (5) Frame Plates. Place a 5/16" Carriage Bolt in the driver side Frame Plate to use for the Emergency Brake Cable Bracket. Mount the Frame Plates on the outside of the truck frame rails by passing a 3/4" X 2" bolt from inside the truck frame through the forward slotted hole in the truck frame. Insert two 1/4" spacer washers between the outside of the truck frame and the Frame Plate, and complete the fastening with a flat washer and a 3/4" nut outside the Frame Plate. Do not fully tighten at this time. This will position the Frame Plate extensions between the Cross Members. Pass 1/2" X 1-1/4" bolts with flat washers from the slotted holes in the Frame Plate extensions. Secure with 1/2" nuts. Do not fully tighten at this time.

Place a 3/4" X 2" bolt in the 3"X 5" Plate washer - With the Plate washer held in its vertical position, pass bolt from inside the truck frame rail through the large hole in the frame and the rear hole in the Frame Plate. Complete this connection using a flat washer and 3/4" nut outside the Frame Plate. With both Frame Plates installed, again square the assembly across the truck frame.

Torque Specifications: Torque all 3/4" bolts to 70 ft. lbs and 1/2" bolts to 65 ft lbs.

- From the driver side, pass the Actuating Rod (6) through the 1/2" hole between the Frame Plate extensions and into the linkage coupler. Align the Actuating Rod so the set screw seats in the hole provided in the rod, and tighten to 7 foot pounds. Be certain the Actuating Rod rotates freely and be certain it moves in and out freely.
- Place the Emergency Brake Cable Bracket on the 5/16" carriage bolt in the Frame Plate and secure with the 5/16" nut.
- Drill four 1/2" holes for the Safety Chain Brackets from under the truck bed. Drill through the **OUTER** four 9/16" holes in the Ball Assembly through the truck bed floor. Remove all tailings. Place a U-bolt in each pair of holes from the top side of the bed. From under the bed place a spring and 1/2" lock nut on each U-bolt leg. Tighten each nut until thread extends through the nut.
- Retract the Retaining Pin by rotating the Actuating Rod 90 degrees counter clockwise. Place the Flip-Over ball in the Socket. Rotate the Actuating Rod 90 degrees clockwise to engage the Retaining Pin.
- Keep the base of the Flip-Over ball lightly lubricated with lithium grease.
- Please read the **SAFE TOWING INSTRUCTIONS** on the Flip-Over WARRANTY sheet.



HARDWARE PROVIDED

- 12 - 1/2" X 1-1/4" Grd. 8 Bolts
- 16 - 1/2" Lock Nuts
- 16 - 1/2" Flat Washers
- 4 - 3/4" X 2" Grd. 5 Bolts
- 4 - 3/4" Nuts
- 4 - 3/4" Flat Washers
- 2 - 1/4" X 3" X 5" Spacers
- 4 - 1/4" Thick 3/4" Spacers
- 1 - 5/16" Carriage Bolt
- 2 - 5/16" X 3/4" Bolts
- 2 - 5/16" Lock Nuts
- 2 - U-Bolts
- 4 - 9/16" X 3" Springs
- 1 - Tailpipe Lowering Bracket

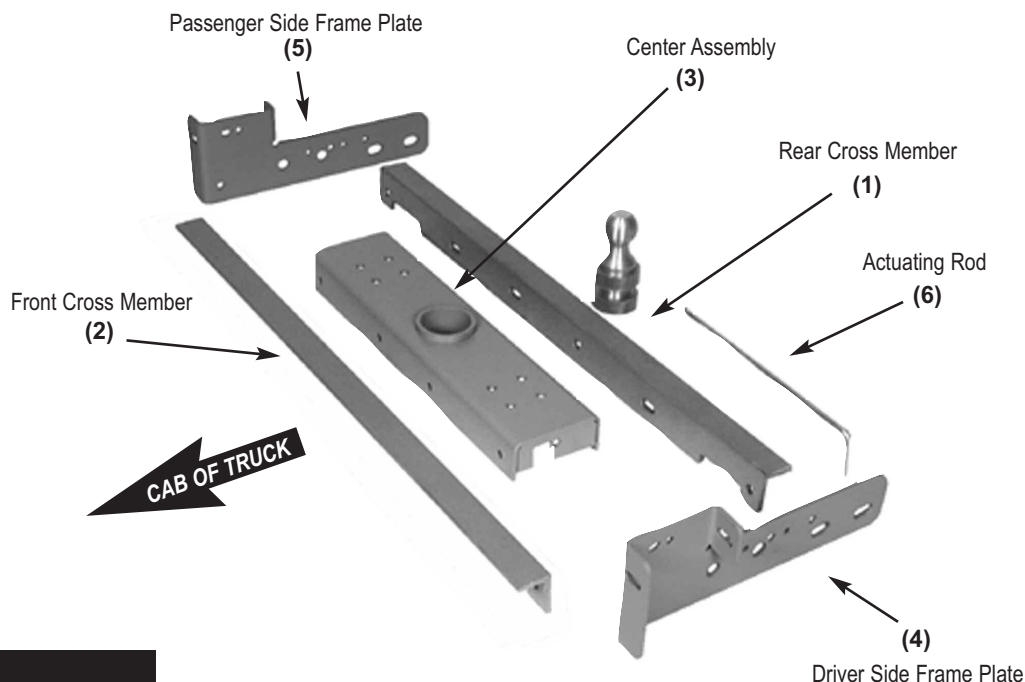

Flip-Over™

Model Number 211
Gross Trailer Weight: 30M lbs.
Gross Trailer Tongue Weight: 7.5M lbs.