



Installation Instructions

Model 207 Chevrolet / GMC

Fits 2007- 2011
1500 Series Only



Model 207 2-2010 FOR THE SAFEST INSTALLATION

WARNING Most pick up trucks have **FUEL LINES** and/or **BRAKE LINES** and/or **ELECTRICAL WIRING** positioned along the truck frame rails where your Flip-Over hitch will install. **BEFORE INSTALLATION** identify and examine the location of fuel lines, brake lines and electrical wires. Be sure you will not damage fuel lines, brake lines or electrical wiring when positioning the hitch components, drilling holes or tightening fasteners.

Be Certain To Avoid Fuel Tanks When Drilling Holes.

- Wear Safety Glasses, Gloves and Particle Mask for protection while installing a FlipOver gooseneck hitch.
- ALWAYS correctly chock tires prior to raising truck with jacking device. For protection in case of jacking device failure ALWAYS use Jack Stands when working under or around a truck which has been raised by a jacking device.
- Be certain the exhaust system is cool prior to installation to avoid possible burns from hot tail pipe and muffler.
- Torque ALL fasteners used in the Flip-Over gooseneck hitch installation as specified in these Installation Instructions.

INSTALLATION PROCEDURE

WARNING: Verify adequate trailer swing clearance between trailer nose and cab of truck.

1. Mark and center punch a location from the rear lip of the truck bed centered between the wheel wells for the **specific truck** the hitch is being installed in, as stated below:

Short Bed Trucks 44 1/2"

Long Bed Trucks 48 1/2"

Center a hole in this location using a 3 1/2" hole saw. Smooth the hole with a file and clean all saw tailings from the bed area before proceeding.

2. Remove the spare tire. If using a vehicle hoist, raise the truck at this time. If using a jacking device, chock the front tires to prevent the truck from rolling. Jacking against the rear bumper or frame, lift the rear of the truck approximately 10". It is not necessary to lift the rear tires off the ground. Properly position jack stands under the rear frame of the truck to protect against jack failure.

3. Remove the entire exhaust heat shield or cut and remove the portion between the bed cross members where the hitch will install. Replace any screws used to secure any sections of heat shield not removed.

4. Identify the Rear Cross Member 1" X 2" bar. Pass it through the driver side wheel well across the top of the truck frame with the **threaded holes nearest the bottom**. Center the Cross Member across the frame rails 3" behind the 3 1/2" hole.

5. To install the Front Cross Angle it is necessary to cut a notch in the lip above the frame where the inner fender and bed floor join. Cut and remove a notch as shown in the illustration 4" ahead of the truck bed cross member ahead of the axle where the hitch will install. Pass the Front Cross Member over the frame through the notch and position across the frame rails with the plain side forward and with the hole side facing the rear of the truck as in the picture on the back page. Use an adjustable wrench to stand the cross angle up with the notches on the truck frame. Center the Cross Member across the frame rails and 6" ahead of the 3 1/2" hole.

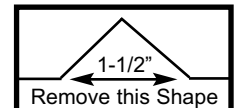

6. Fasten the Center Assembly to the Front Cross Member with 1-1/4" bolts. Slide the Rear Cross Member forward and fasten it to the Center Assembly with 1-1/4" bolts with washers on the slotted holes and 1/2" nuts. Do not fully tighten these fittings at this time. Square the assembled Cross Members and Center Assembly across the frame from to back and side to side.

INSTALLATION PROCEDURE - CONTINUED

7. Identify the driver side (with labels) and passenger side Frame Plates. Fasten to the front and rear crossmembers with 1 1/4" bolts using flat washers over the oval holes and lock nuts. **Do not fully tighten these fittings at this time.**
8. Secure the Frame Plates to the frame with the 4 5/8" u-bolts.
9. Insert the short end (with nut) of the **angle nut bracket** thru the 3/4" slotted hole on the inside of the truck frame. Secure with 1/2" bolt.
10. **CAUTION: Use this sequence for tightening Frame Plate fasteners:** 1. Snug the center section to the cross rails. 2. Snug the Cross rails to the side plates. 3. Snug the frame plate u-bolt and the 1/2" x 1 1/4" bolt. Using the same sequence, torque the 1/2" bolts to **65 Foot Pounds** and the U-Bolts to **50 ft. lbs.** . **Use a Torque Wrench. Do not overtighten.**
11. Drill four 1/2" holes for the Safety Chain Brackets from under the truck bed. Drill through the two pairs of holes in the Center Assembly that are **nearest to the hitch ball**. Place a U-bolt in each pair of holes from the top side of the bed. From under the bed place a spring and 1/2" nut on each U-bolt leg. Tighten each nut until thread extends through the nut.
12. From the drivers side, pass the Actuating Rod thru the hole between the Frame Plate extensions and into the linkage coupler. Align the Actuating Rod so the set screw seats in the hole provided in the rod, and tighten to 15 foot pounds. You may need to remove some of the lip above where the Actuating Rod installs to allow free travel.
13. Retract the Retaining Pin by rotating the Actuating Rod 90 degrees counter clockwise. Place the Flip-Over ball in the Socket. Rotate the Actuating Rod 90 degrees clockwise to engage the Retaining Pin.
14. Keep the base of the Flip-Over ball lightly lubricated with lithium grease.
15. Please read the **SAFE TOWING INSTRUCTIONS** on the Flip-Over WARRANTY sheet.

IMPORTANT! The solid Cross Bar and Cross Angle must both rest on the truck frame.



HARDWARE PROVIDED

- 14 - 1/2" X 1-1/4" Grd. 8 Bolts
- 16 - 4 1/2" Lock Nuts
- 12 - 1/2" Flat Washers
- 2 - Angled Nut Holders
- 2 - 4 5/8" U-Bolts
- 2 - Safety Chain U-Bolts
- 4 - Springs

Torque Specifications

- 1/2" Gr 8 Bolts - 65 ft. lbs
- 5" U-Bolts - 50 ft. lbs

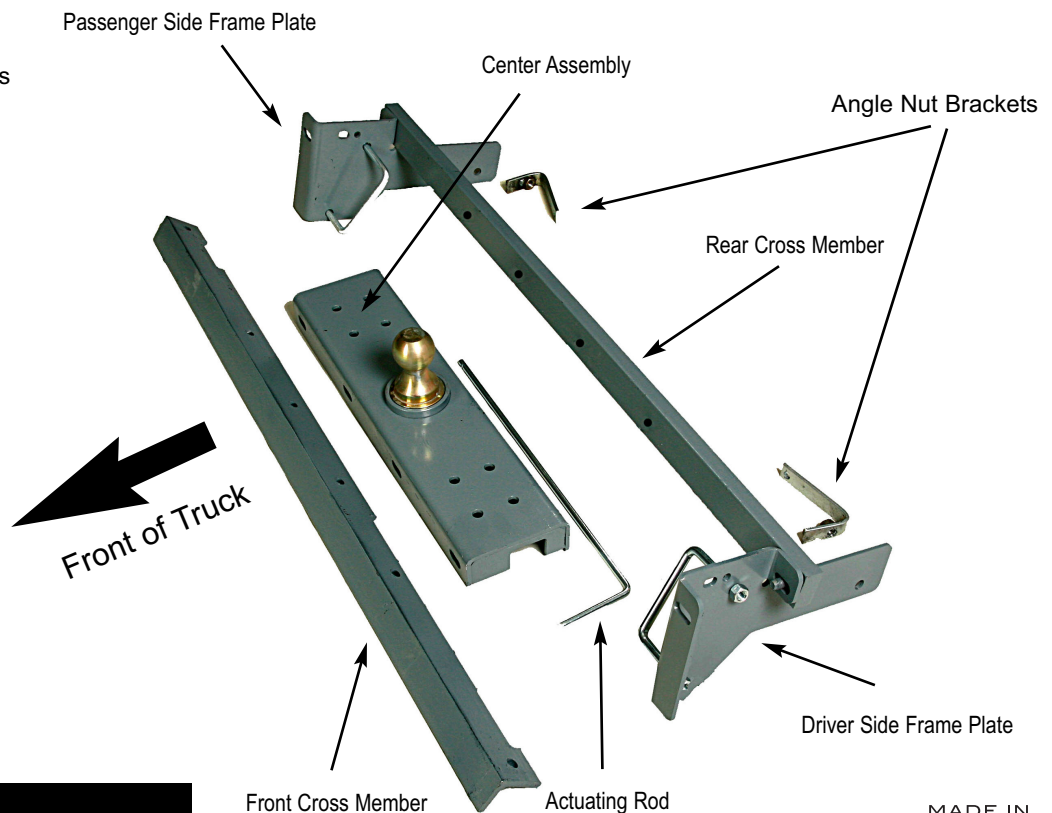

Flip-Over™

Model Number 207
Gross Trailer Weight: 30M lbs.
Gross Trailer Tongue Weight: 7.5M lbs.

MADE IN

U. S. A.