

## Installation Instructions

**Model 110**  
**Ford Classic Style**  
Fits 0980 - 1998  
Long & Short Bed -1/2, 3/4 & 1 Ton



**PopUp**<sup>®</sup>  
Towing Products

## MODEL 110 10-2010 FOR THE SAFEST INSTALLATION

**WARNING** Most pick up trucks have **FUEL LINES** and/or **BRAKE LINES** and/or **ELECTRICAL WIRING** positioned along the truck frame rails where your PopUp hitch will install. **BEFORE INSTALLATION** identify and examine the location of fuel lines, brake lines and electrical wires. Be sure you will not damage fuel lines, brake lines or electrical wiring when positioning PopUp hitch components, drilling holes or tightening fasteners. **Be Certain To Avoid Fuel Tanks When Drilling Holes.**

- Wear Safety Glasses, Gloves and Particle Mask for protection while installing a PopUp [gooseneck hitch](#).
- ALWAYS correctly chock tires prior to raising truck with jacking device. For protection in case of jacking device failure ALWAYS use Jack Stands when working under or around a truck which has been raised by a jacking device.
- Be certain the exhaust system is cool prior to installation to avoid possible burns from hot tail pipe and muffler.
- Torque ALL fasteners used in the PopUp gooseneck hitch installation as specified in these Installation Instructions.

## INSTALLATION PROCEDURE

**CAUTION:** If larger after-market wheels and/or tires have been installed verify adequate Actuating Rod clearance.

**CAUTION:** Verify adequate clearance between trailer and both cab of tow vehicle and rear of tow vehicle. Compensate for trailer swing during turning.

**TO INSTALL IN 1/2 TON TRUCKS:** Cut notches in front and rear Cross Members 1/2" deeper, bend Actuating Rod as shown in illustration on reverse side, and trim lip formed where fender well and bed floor join for adequate Actuating Rod clearance.

1. Mark and center punch a location **50-7/16"** from the rear lip of the truck bed floor centered between the wheel wells. Use a 3" hole saw to cut a hole in the bed floor centered at this location. Remove all saw tailings from the bed area before proceeding.

2. Remove the spare tire. If using a vehicle hoist, raise the truck at this time. If using a jacking device Chock the front tires to prevent the truck from rolling. Jacking against the rear bumper or frame, lift the rear of the truck approximately 10". It is not necessary to lift the rear tires off the ground. Properly position jack stands under the rear frame of the truck to protect against jack failure.

3. Remove the heat shield located above the tail pipe.

**Power Stroke Diesel** requires loosening the tail pipe bracket forward of the rear axle to hold the tail pipe low enough to install hitch. After installing ,place a 1/4" shim in the tail pipe bracket and tighten.

4. Identify the Rear Cross Member (1), the angle with the deepest notches. With the plain side (2" leg) up and with the slotted side (2-1/2") facing the front of the truck, slide the Cross Member across the frame rails from the driver side wheel well forward of the rear axle. Slide the Cross Member rearward onto the highest part of the frame rails. Position the Cross Member approximately square across the frame rails and about 6" behind the hole in the bed floor.

5. Slide the Front Cross Member (2) across the frame rails similarly, with the plain side (2" leg) up and with the slotted side facing rearward. Position the Forward Cross Member about 3" forward of the hole in the bed floor.

6. Screw the 3/8" eye bolt into the top of the ball. Position the Center Assembly between the Cross Members with the hole for the pull rod facing the drivers side and inserting the 3" tube in the hole cut in the bed floor. Secure it to an overhead lifting device attached to the eye bolt to hold it firmly against the underside of the bed floor. Fasten the Center Assembly to the Cross Members with eight 1/2" X 1-1/4" bolts and lock nuts. Do not fully tighten at this time.

7. Square the assembled Cross Members and Ball Assembly across the frame. Identify the driver side (4, with labels) and passenger side (5) Frame Plates.. Mount the Frame Plates on the outside of the truck frame rails by passing a 3/4" bolt with flat washer from inside the truck frame through the large hole in the truck frame. Insert two 1/4" spacer washers between the outside of the truck frame and the Frame Plate, and complete the fastening with a 3/4" nut and flat washer outside the Frame Plate. **Do not fully tighten at this time.**

8. Fasten the Cross Angles to the frame plates with 1/2" x 1 1/4" bolts with flat washers over the slotted holes in the frame plates. **Do not fully tighten at this time.**

(over)

## INSTALLATION PROCEDURE - CONTINUED

9. Use a 1/2" drill bit to center a location in the frame rail at the slotted hole in the Frame Plate. Drill a 1/4" pilot hole and complete with a 1/2" drill bit. Pass a 1 1/4" bolt from inside the frame rail and fasten with a flat washer and nut.
10. Drill four 1/2" holes for the Safety Chain Brackets from under the truck bed. Drill through the **OUTER** four 9/16" holes in the Ball Assembly through the truck bed floor. Remove all tailings. Place a U-bolt in each pair of holes from the top side of the bed. From under the bed place a spring and 1/2" lock nut on each U-bolt leg. Tighten each nut until thread extends through the nut.
11. Place the Emergency Brake Cable Bracket on the 5/16" carriage bolt in the Frame Plate and secure with the 5/16" nut.
12. From the driver side, pass the Actuating Rod (6) through the 1/2" hole between the Frame Plate extensions and through the slotted hole in the end of the Ball Assembly and into the coupler at the small end of the slide. Align the Actuating Rod so the set screw seats in the hole provided in the rod, and tighten to 7 foot pounds.

**Torque 3/4" bolts to 70 foot pounds and 1/2" fasteners to 65 foot pounds.**

## IMPORTANT!

The final step is to raise the ball and check the position of the slide from under the truck.

When the ball is fully raised, the Roll Pin Stop should be against the ball tube. This allows the Detent Ball to lock the slide in place and positions the ball over the flat surface at top of the slide.

In this position it is impossible for the ball to retract without manually pushing in the handle.

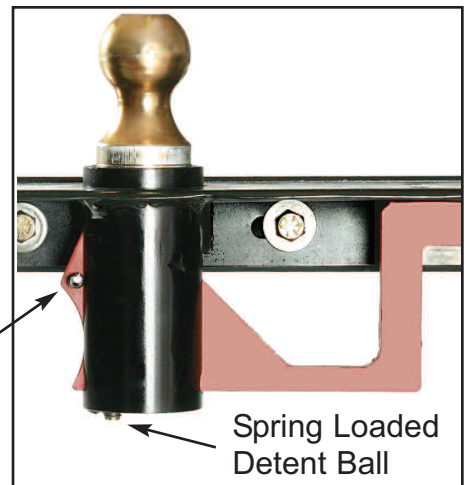

Read the **SAFE TOWING INSTRUCTIONS** on the **PopUp Warranty** sheet.



When installing in 1/2 Ton Truck bend Actuating Rod as shown.

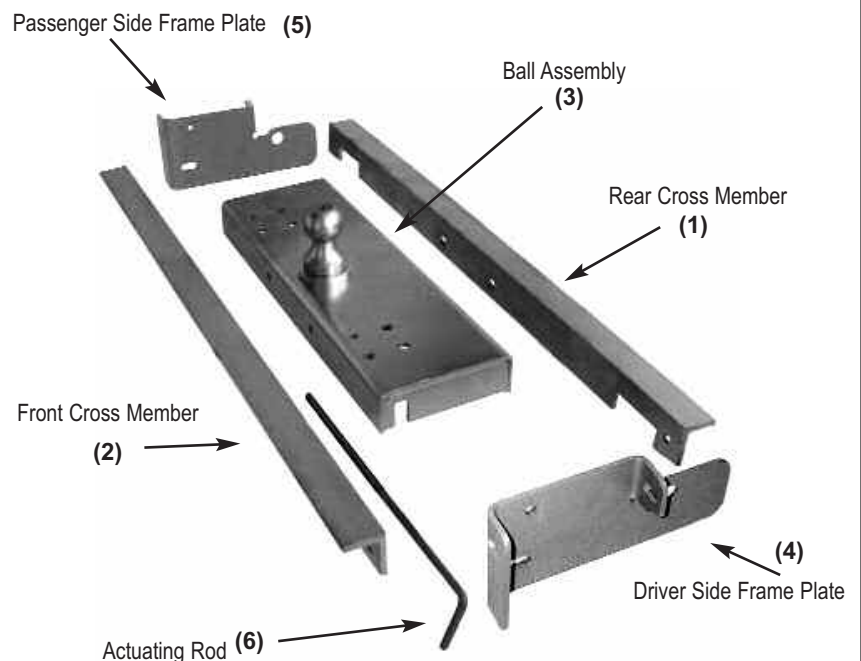

**Model Number 110**  
**Gross Trailer Weight: 30M lbs.**  
**Gross Trailer Tongue Weight: 7.5M lbs.**

# IMPORTANT!

Before installing the actuating rod place the indicator / lock collar on the rod toward the bend for the handle.

As a last step firmly pull the handle to raise the ball, verify that the Roll Pin Stop is against the ball tube. Then slide the indicator / lock collar against the outside of the frame plate and secure it in this position using a 1/8" allen wrench.

With the indicator / lock collar in place raise the actuator rod slightly and push in to lower the ball. To raise the ball raise the handle and pull the actuator rod out till the indicator / lock collar clears the frame plate. This gives a positive indication that the ball is fully raised and is ready for towing.

**Pop up**<sup>®</sup> Towing Products

Indicator /  
Lock Collar

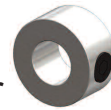

Frame  
Plate

