



Installation Instructions

Model 107
Chevrolet / GMC
Fits 2007 - 2011
Does Not Fit 2012
1500 Series Only



Model 107 11-2011 FOR THE SAFEST INSTALLATION

WARNING Most pick up trucks have **FUEL LINES** and/or **BRAKE LINES** and/or **ELECTRICAL WIRING** positioned along the truck frame rails where your PopUp hitch will install. **BEFORE INSTALLATION** identify and examine the location of fuel lines, brake lines and electrical wires. Be sure you will not damage fuel lines, brake lines or electrical wiring when positioning the hitch components, drilling holes or tightening fasteners.

Be Certain To Avoid Fuel Tanks When Drilling Holes.

- Wear Safety Glasses, Gloves and Particle Mask for protection while installing a PopUp [gooseneck hitch](#).
- ALWAYS correctly chock tires prior to raising truck with jacking device. For protection in case of jacking device failure ALWAYS use Jack Stands when working under or around a truck which has been raised by a jacking device.
- Be certain the exhaust system is cool prior to installation to avoid possible burns from hot tail pipe and muffler.
- Torque ALL fasteners used in the PopUp gooseneck hitch installation as specified in these Installation Instructions.

INSTALLATION PROCEDURE

WARNING: Verify adequate trailer swing clearance between trailer nose and cab of truck.

1. Mark and center punch a location from the rear lip of the truck bed centered between the wheel wells for the **specific truck** the hitch is being installed in, as stated below:

Short Bed Trucks 44"

Long Bed Trucks 48"

Center a hole in this location using a 3" hole saw. Smooth the hole with a file and clean all saw tailings from the bed area before proceeding.

2. Remove the spare tire. If using a vehicle hoist, raise the truck at this time. If using a jacking device, chock the front tires to prevent the truck from rolling. Jacking against the rear bumper or frame, lift the rear of the truck approximately 10". It is not necessary to lift the rear tires off the ground. Properly position jack stands under the rear frame of the truck to protect against jack failure.

3. Remove the entire exhaust heat shield or cut and remove the portion between the bed cross members where the hitch will install. Replace any screws used to secure any sections of heat shield not removed.

4. Identify the Rear Cross Member 1" X 2" bar. Pass it through the driver side wheel well across the top of the frame rails with the threaded holes nearest the bottom side. Center the Cross Member across the frame rails 3" behind the 3" hole.

5. To install the Front Cross Member it is necessary to cut a notch in the lip above the frame where the inner fender and bed floor join. Cut and remove a notch as shown in the illustration 4" ahead of the truck bed cross member ahead of the axle where the hitch will install. Pass the Front Cross Member over the frame through the notch and position across the frame rails with the plain side forward and with the hole side facing the rear of the truck. Use an adjustable wrench to stand the cross angle up with the notches on the truck frame. Center the Cross Member across the frame rails and 6" ahead of the 3" hole.

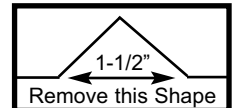

6. Orient the Center Section so the end of the slide that attaches to the pull rod is facing the drivers side of the truck, raise the Ball Assembly into position between the Cross Members with the protruding tube fitting in the 3" hole. With the provided eye bolt threaded into the top of the ball, use an overhead lifting device, or a saw horse in the bed of the truck, and cable or rope to hold the Center Assembly firmly against the underside of the bed floor.

INSTALLATION PROCEDURE - CONTINUED

7. Fasten the Center Assembly to the Front and Rear Crossmembers using flat washers and 1 1/4" bolts and lock nuts. **Pull the slack out of the bolts but do not tighten at this time.** Square the assembled Cross Members and Center Assembly across the frame.

8. Identify the driver side (with labels) and passenger side Frame Plates. Fasten to the cross bar and angle with flat washers and 1 1/4" bolts and lock nuts. **Do not tighten at this time.**

9. Secure the Frame Plates to the frame with the 4 5/8" u-bolts, one on each side. Insert the short end (with nut) of the **angle nut bracket** thru the 3/4" slotted hole on the inside of the truck frame. Secure with 1/2" bolt.

10. **Torque 1/2" fasteners to 65 foot pounds** in the following sequence: First the Cross Members to Center Assembly, then the Cross Members to the Frame Plates, and last the Frame Plates to the truck frame.

11. Drill four 1/2" holes for the Safety Chain Brackets from under the truck bed. Drill through the two pairs of holes in the Center Assembly that are **nearest to the hitch ball**. Place a U-bolt in each pair of holes from the top side of the bed. From under the bed place a spring and 1/2" nut on each U-bolt leg. Tighten each nut until thread extends through the nut.

12. From the drivers side, pass the Actuating Rod through the upper slotted hole between the Frame Plate extensions and into end of the slide. Align the Actuating Rod so the set screw seats in the hole provided in the rod, and tighten to 15 foot pounds.

IMPORTANT! The Solid Rear Cross Bar and Cross Angle must both rest on the truck frame.

IMPORTANT!

The final step is to raise the ball and check the position of the slide from under the truck.

When the ball is fully raised, the Roll Pin Stop should be against the ball tube. This allows the Detent Ball to lock the slide in place and positions the ball over the flat surface at top of the slide.

In this position it is impossible for the ball to retract without manually pushing in the handle.

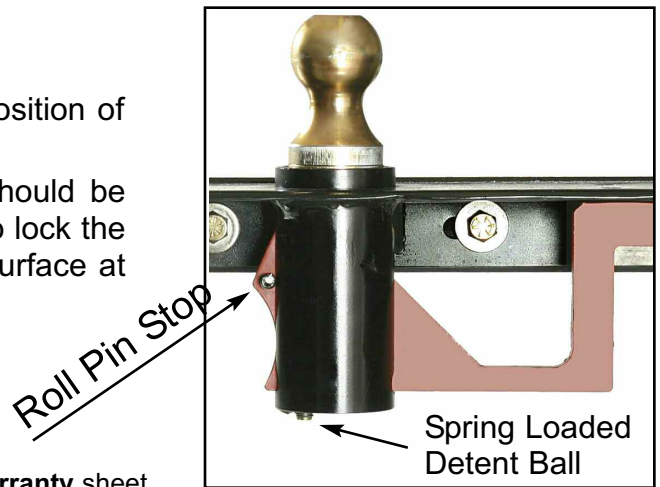

Read the **SAFE TOWING INSTRUCTIONS** on the **PopUp Warranty** sheet.

HARDWARE PROVIDED

- 14 - 1/2" X 1-1/4" Grd. 8 Bolts
- 14 - 1/2" Lock Nuts
- 12 - 1/2" Flat Washers
- 2 - Angled Nut Holders
- 2 - 4 5/8" U-Bolts
- 2 - Safety Chain U-Bolts
- 1 - Eye Bolt
- 1 - Plastic Cap
- 4 - Springs

Torque Specifications

- 1/2" Gr 8 Bolts - 65 ft. lbs
- 5" U-Bolts - 50 ft. lbs

PopUp[®]
Towing Products

Model Number 107
Gross Trailer Weight: 30M lbs.
Gross Trailer Tongue Weight: 7.5M lbs.

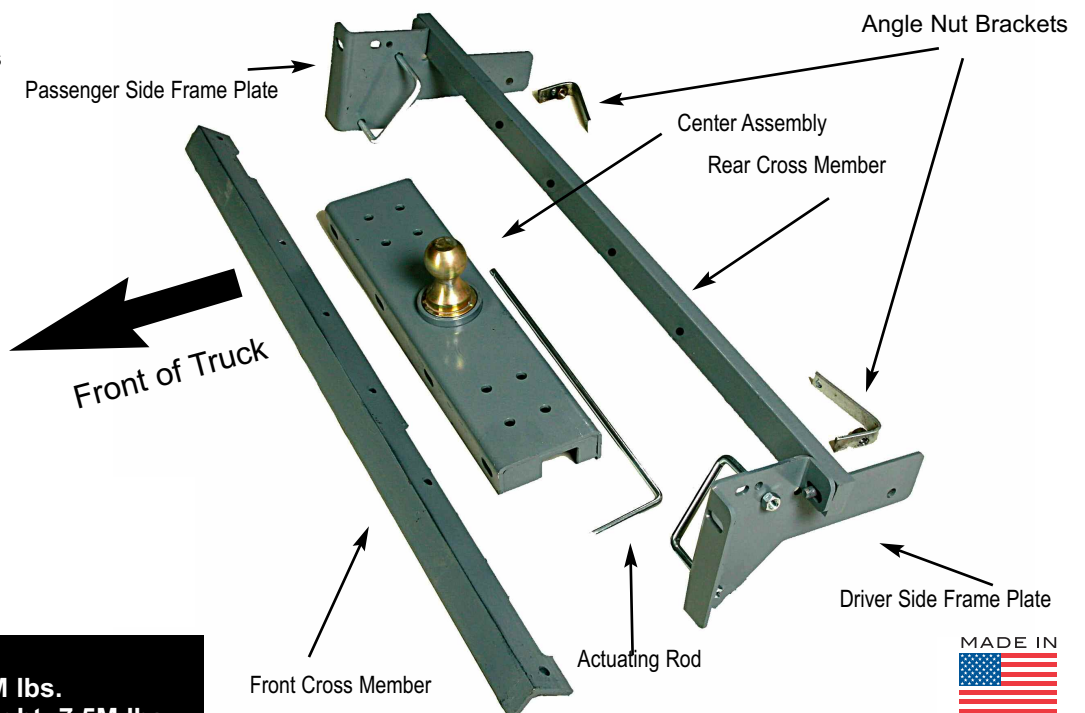

MADE IN

U. S. A.

IMPORTANT!

Before installing the actuating rod place the indicator / lock collar on the rod toward the bend for the handle.

As a last step firmly pull the handle to raise the ball, verify that the Roll Pin Stop is against the ball tube. Then slide the indicator / lock collar against the outside of the frame plate and secure it in this position using a 1/8" allen wrench.

With the indicator / lock collar in place raise the actuator rod slightly and push in to lower the ball. To raise the ball raise the handle and pull the actuator rod out till the indicator / lock collar clears the frame plate. This gives a positive indication that the ball is fully raised and is ready for towing.

Pop up[®] Towing Products

Indicator /
Lock Collar

