

## Installation Instructions

# RV4 & RV4XL

9" offset adapter  
Fits standard OEM pin box



Revised 1/12/16



### CAUTION:

**CAUTION:** Verify the quality of all existing welds in the king pin box assembly.

**CAUTION:** Verify adequate trailer swing clearance between trailer nose and cab of truck, and trailer and rear of truck.

## Model RV4 & RV4XL

### **WARNING: Verify adequate trailer swing clearance between trailer nose and cab of truck, and trailer and rear of truck**

#### **Use of Adapters is NOT RECOMMENDED on cushioned king pin boxes.**

1. Remove lube plate if so equipped and thoroughly de-grease the king pin and the bottom of the king pin plate before proceeding. Position the large hole in the RV4 over your king pin and against your king pin plate with the gooseneck coupler facing forward. With the RV4 square to the king pin box secure in position with vise clamps..
2. Position the King Pin Clamp on the king pin with the four cup point set bolts down and with the two 3/4" holes accessible through the large holes in the side of the RV4. Insert two 3/4" bolts and snug. Square the King Pin Clamp to the RV4 and **torque bolts to 240 ft. lbs.**
3. Alternately tighten the four Cup Point Set Bolts in the King Pin Clamp against the king pin box. **Torque to 85 ft. lbs.**
4. **It is necessary to bolt the RV4 to the king pin box:**

**Bolting to a 10" X 10" or larger king pin plate, that is at least 1/4" thick:** Install the eight 3/8" bolts provided in the four holes closest to the corners of the king pin plate. Bolts should also be installed in the four center holes on all four sides of the king pin plate if fitting them is possible.

If you have access inside the king pin box, drill 3/8" holes and use washers and nuts to fit the 3/8" bolts. **Torque to 28 ft.lbs.** If the king pin box is sealed, mark the hole centers, drill 5/16" holes and tap to 3/8"-16. Fit the 3/8" bolts. **Torque to 20 ft. lbs.**

**Under-Size King Pin Plate:** A king pin plate that is smaller than 10" X 10" requires welding for a safe installation. When it is not possible to bolt through the perimeter mounting holes, have a qualified welder apply a stitch-weld where the king pin plate and RV4 meet. (Example: A 9" deep and 12" wide plate can use 3/8" bolts in the side holes but requires a stitch-weld across the front and back perimeter.)

**Light Gauge King Pin Plate:** A king pin plate less than 1/4" thick should not be drilled and tapped for installing the 3/8" perimeter mounting bolts. For these installations, use heavy washers with nuts on the top side of the king pin plate. If access inside the king pin box is not possible, have a qualified welder apply a stitch-weld around the perimeter where the king pin plate and RV4 meet.

Model Number RV4 & RV4XL  
Gross Trailer Weight: 24,000 lbs.  
Gross Trailer Tongue Weight: 6,000 lbs.

5. Attach the coupler release cable to the coupler lever with a cable clamp. Route the cable up and rearward through eye-bolts to near the trailer jack switch or handle. Secure the cable to an eyebolt near the trailer jack switch or handle with a cable clamp in such a way that the coupler can be un-latched by pulling on the cable while standing at the trailer jack switch or handle. Coupler will latch remotely when lowered onto gooseneck ball. Lubricate the inside of the coupler with a thin film of lithium grease.

6. Install High Test safety chains (not provided with adapter) to the trailer. Safety chains must be attached to the trailer at a point at least as strong as the chain. Do not weld safety chains to the trailer because welding will weaken the welded chain link and the link or weld may fail in an accident. **Always use safety chains when towing with an RV4 Fifth Wheel Adapter.**

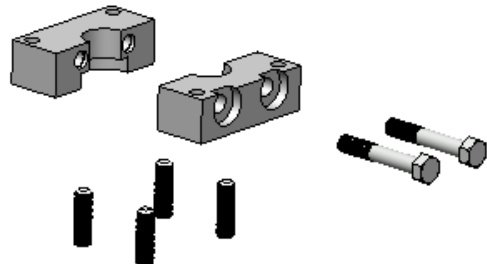
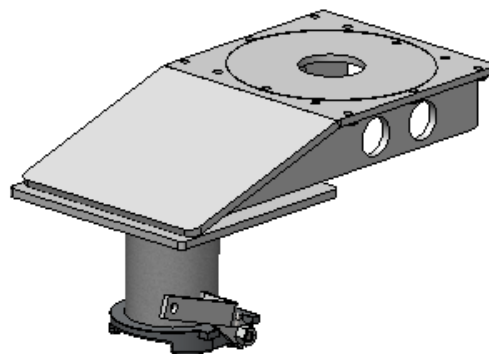
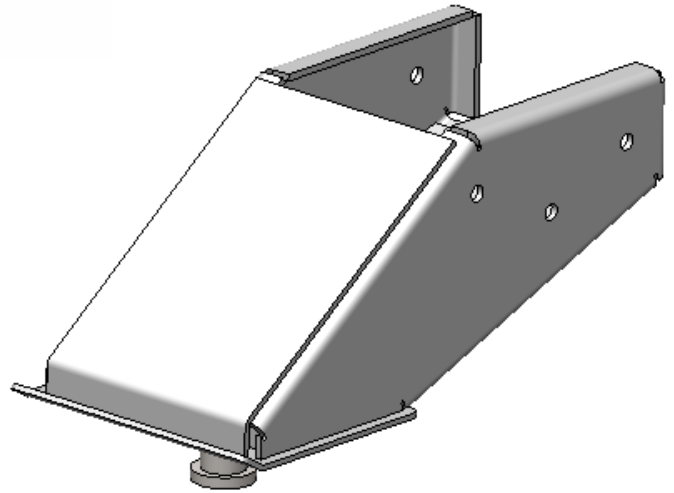

### Hardware Provided

- 2 - 3/4" x 10 x 3 1/4"
- 4 - 3/4" x 10 x 2 1/2" set bolts
- 8 - 3/8" lock nuts
- 8 - 3/8" x 1/2" bolts
- 8 - 3/8" flat washers
- 1 - Clamp block

Model Number RV4 & RV4XL  
Gross Trailer Weight: 24,000 lbs.  
Gross Trailer Tongue Weight: 6,000 lbs.