



Installation Instructions

PopUp Model 128 Chevrolet / GMC

Fits 1999 - 2006 (1/2 ton)

Fits 2001 - 2010 (3/4 ton)

Fits 2007-2010 (1 ton)



FOR THE SAFEST INSTALLATION

11/15

WARNING Most pick up trucks have **FUEL LINES** and/or **BRAKE LINES** and/or **ELECTRICAL WIRING** positioned along the truck framerrails where your under-bed hitch will install. **BEFORE INSTALLATION** identify and examine the location of fuel lines, brake lines and electrical wires. Be sure you will not damage fuel lines, brake lines or electrical wiring when positioning the hitch components, drilling holes or tightening fasteners. **Be Certain To Avoid Fuel Tanks When Drilling Holes.**

- Wear Safety Glasses, Gloves and Particle Mask for protection while installing a under-bed gooseneck hitch.
- ALWAYS correctly chock tires prior to raising truck with jacking device. For protection ALWAYS use jack stands when working under or around a truck which has been raised by a jacking device.
- Be certain the exhaust system is cool prior to installation to avoid possible burns from hot tail pipe and muffler.
- Torque ALL fasteners used in the under-bed gooseneck hitch installation as specified in these Installation Instructions.
- **READ ALL SAFETY AND WARNINGS ON THE LAST PAGE OF THE PROVIDED INSTRUCTIONS.**

INSTALLATION PROCEDURE

WARNING: Verify adequate trailer swing clearance between trailer nose and cab of truck, and trailer and rear of truck. READ spray in bed liner warning on last page.

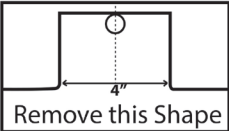
1. Mark and center punch a location from the rear lip of the truck bed (where the tailgate hinges) centered between the wheel wells for the specific truck the hitch is being installed in, as stated below: **Short Bed Trucks 43-3/4"**
Long Bed Trucks (8' Bed) 49" Center a hole in this location using a **3" hole saw**. Smooth the hole with a file and clean all saw tailings from the bed area before proceeding.
2. Remove the spare tire if more room is needed. If using a vehicle hoist, raise the truck at this time. If using a jacking device, always chock the front tires to prevent the truck from rolling. Jacking against the rear bumper or frame, lift the rear of the truck approximately 10". **It is not necessary to lift the rear tires off the ground.** Properly position jack stands under the rear frame of the truck to protect against jack failure.
3. Remove the entire exhaust heat shield or cut and remove the portion between the bed cross members where the hitch will install. Replace any screws used to secure any sections of heat shield not removed. Cut 1" off of the top of the rearward 4" of the metal shield that protects the fuel tank. This will provide clearance for the Center Assembly.
4. Pass the Rear Cross Member 1" X 2" bar across the top of the frame rails. Using an adjustable wrench, turn the bar up with the threaded holes nearest the bottom side. Center the Cross Member across the frame rails 3" behind the 3" hole.
5. Cut and remove a notch in the fender lip as shown here, 4" ahead of the truck bed sill located forward of the axle. Pass the Front Angle Cross Member over the frame through the notch with the plain side forward and with the hole side facing the rear of the truck. Center the Cross Member across the frame rails approximately 6" ahead of the 3" hole.

Remove this Shape
6. Raise the Center Assembly into position under the truck bed with the end of the slide that attaches to the actuating rod toward the drivers side and the protruding tube passing into the 3" hole. Use an overhead lifting device, or a saw horse in the bed of the truck, with a cable or strap attached to the 3/8" eye bolt screwed into the threaded hole in the top of the ball. Hold the Center Assembly firmly against the underside of the bed floor. **Do not pull it up so tight that it bows the truck bed.**
7. Fasten the Center Assembly to the Front and Rear Cross Member using flat washers and 1 1/4" bolts. **Pull the slack out of the bolts but do not tighten at this time.** Square the assembled Cross Members and Center Assembly across the frame.
8. Fasten the Frame Plate tangs to the Crossmembers using 1 1/4" bolts with flat washers and lock nuts. **Pull the slack out of the bolts but do not tighten at this time.**

INSTALLATION PROCEDURE- CONTINUED

9. Fasten the Frame Plates to the frame by passing a 3/4" bolt with a flat washer through the slotted hole from inside the frame using a flat washer and nut **do not tighten at this time**. Trucks equipped with factory installed brake control, have a sensor blocking the slotted hole. Either relocate the sensor or drill a 1/2" hole using the Optional Rear Hole in the frame plate as a guide and install a 1 1/4" bolt and locking nut in that hole. If drilling the optional hole, make that your final step after tightening all the other fasteners so the frame plate won't shift positions while drilling. **NOTE:** Most installers prefer to remove one of the bolts holding the sensor and turn the sensor out of the way and re-tighten the other bolt. Pass the 8 5/16" wide u-bolt from inside the truck frame thru the round holes in the frame plate above and below the truck frame. **Pull out the slack using flat washers and lock nuts.** **CAUTION:** Avoid fuel tank, brake lines and/or wiring.
10. Square the hitch across the frame. **Tighten the bolts in the following sequence.** **First** tighten the bolts holding the Center Section to the Cross Bar and Angle. Important: **Next**, release the Center Section from the overhead lifting device. Check to ascertain that the cross angle and bar are resting securely on the frame. **Next** tighten the Frame Plates to the frame, **then** Cross Members to the Frame Plates, Follow the **torque specifications** listed below.
11. Drill four 1/2" holes for the Safety Chain Brackets from under the truck bed. Drill through the two pairs of holes in the Center Assembly that are nearest to the hitch ball. Place a U-bolt in each pair of holes from the top side of the bed. From under the bed place a spring and 1/2" nut on each U-bolt leg. **Tighten each nut until thread extends through the nut.**
12. From the driver side, pass the Actuating Rod through the the slotted hole between the Frame Plate extensions and into the mating hole at the end of the slide assembly. Align the Actuating Rod so the set screw seats in the hole provided in the rod, and tighten to **torque specifications**. Be certain the Actuating Rod moves in and out freely.
13. The final step is to raise the ball and check the position of the slide from under the truck. When the ball is fully raised, the Roll Pin Stop should be against the ball tube. This allows the Detent Ball to lock the slide in place and positions the ball over the flat surface at top of the slide. In this position it is impossible for the ball to retract without manually pushing in the handle.
14. Please read the **SAFE TOWING INSTRUCTIONS** on the WARRANTY sheet.

Torque Specifications:

1/2" Gr 8 Bolts - 119 ft. lbs
3/4" Gr Bolts - 155 ft. lbs
5" U-bolts - 50 ft. lbs.
Actuating rod set screw - 15 ft. lbs.
Frame plate U-Bolts - Tighten until the tabs bend in **slightly**.

Hardware Provided

14 - 1/2" X 1-1/4" Grd. 8 Bolts
12 - 1/2" Lock Nuts
14 - 1/2" Flat Washers
2 - 8 - 5/16" U-Bolts
2 - 3/4" X 2" Bolts
2 - 3/4" Lock Nuts
4 - 3/4" Flat Washers
2 - U-Bolts w/springs
1 - 3/8" Eye Bolt
1 - Plastic Cap
2 - Frame U-Bolts
4 - 1/2" Lock Nuts
4 - 1/2" Washers

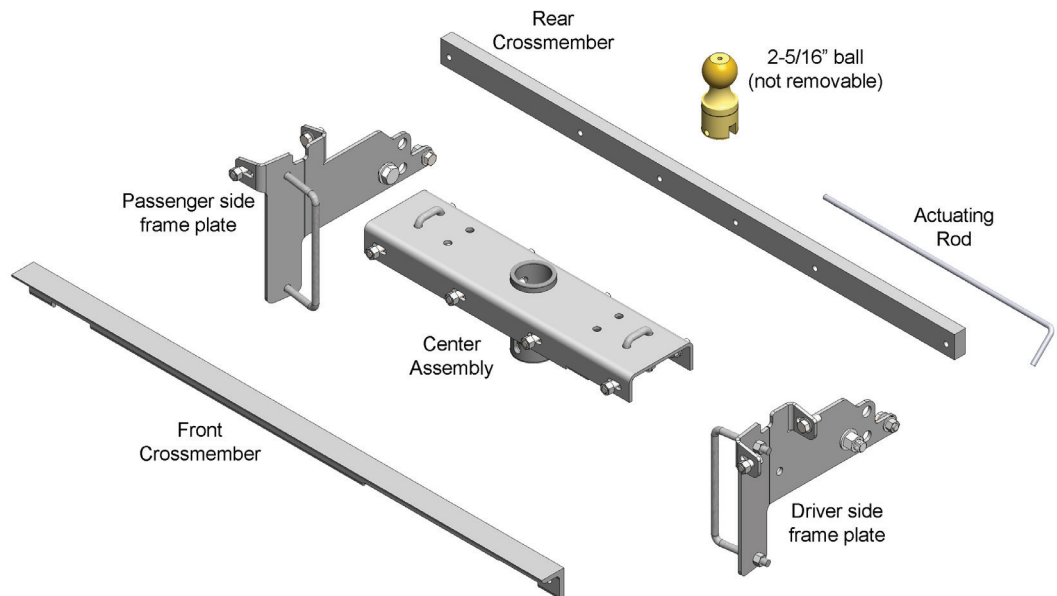

Model Number 128
Gross Trailer Weight: 30M lbs.
Gross Trailer Tongue Weight: 7.5M lbs.

Popup[®]



READ ALL SAFETY AND WARNINGS BEFORE STARTING THE INSTALL

WARNING AND SAFETY INFORMATION, READ ENTIRELY BEFORE INSTALLATION.

Read all installation and operating instructions along with all labels before using this product.

PopUp Towing's under-bed hitches are standard with a 2-5/16" ball. Make sure the coupler on the trailer is designed for 2-5/16" ball. Using a larger size coupler could cause loss of attachment and cause serious injury.

Do not modify this product in any manner. Doing so could alter the integrity and proper use of the product causing serious damage or injury.

Do not exceed tow or tongue rating of coupler, tow or tongue rating of the hitch, or tow or weight ratings of the truck or trailer. See vehicle and trailer manufacturer information for proper ratings. Exceeding these ratings may cause damage to truck and/or trailer, or possible bodily injury.

Adding components such as a PopUp Towing under-bed gooseneck hitch to the chassis of any vehicle can be hazardous. There is potential for unexpected combustion of fuel, electric shock, burns, shifting or falling of unstable vehicle, damage to vehicle, injury from tool usage and many other hazards. This installation must be completed by someone who is aware of the hazards involved.

Always be sure the ball is properly latched into place while in the up or down position. Before hauling heavy loads make sure that your hitch will clear the truck's differential before hauling a load.

Cab clearance can be an issue with short bed trucks and limits towing on certain trailers. Failure to insure that there is adequate clearance before towing, may result in property damage, or serious injury.

IMPORTANT: The hitch is designed to install only at the location described in the included instructions. Failure to place the ball hole precisely may result in property damage or difficulty during installation.

Failure to follow the bolt tightening sequence and torque settings listed above may result in the hitch being misaligned which could affect the performance of the hitch, or result in property or bodily damage.

PopUp Towing Products assumes no responsibility for injury to self, or damage that may occur during installation. As always its best to have this product installed by an experienced installer.

CAUTION: If your truck is equipped with a spray in bed liner that covers the rear lip of the truck bed, make sure and add the thickness of the bed liner to the hole location measurement before drilling the hole.