

# POWER TAILGATE LOCK

## Instructions

Model PL 8521 for the TOYOTA TACOMA with and w/o camera , '05 and up

### Layout :

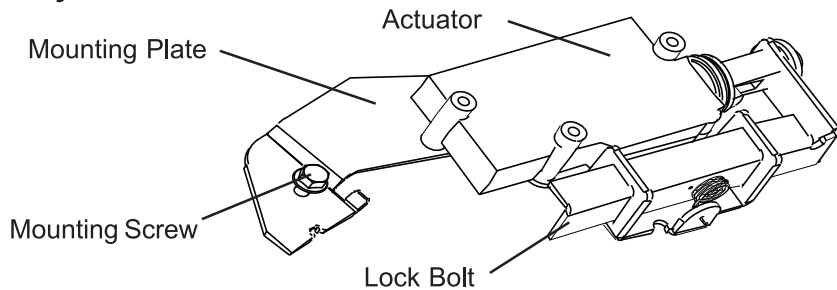

### Parts Included:

Power Tailgate Lock Unit  
Short Wiring Cable  
Long Wiring Cable  
Cable Ties  
Blue Connector Tap

### Tools Required:

10 MM Socket  
T-30 Torx driver  
Pliers

### Installation:

1. Lower the tailgate and remove the access panel using a T-30 Torx driver to undo the 15 bolts.
2. Release the driver's side rod end and the mounting screw on the driver's side with a 10 MM socket .
3. Place the POWER LOCK inside the tailgate on the driver's side as shown below.
4. Insert and tighten the mounting bolt with a 10 MM socket to secure the POWER LOCK. Re-connect the rod end.

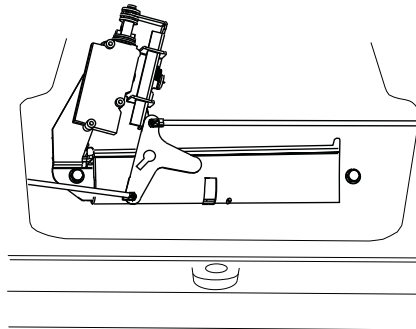

5. **Wiring:** Feed the round bullet connectors on the end of the short wiring cable into a drain hole at the bottom of the tailgate and up the tailgate to the handle opening. Connect them to the wires of the POWER LOCK. Feed the other end into the gap between the bumper and the truck bed and connect it to the long wire harness. Locate the connector so that you can reach it to remove the tailgate. Coil and tie the extra length of the short wiring harness inside the tailgate. Don't attach it to the truck.
6. Route the long wire harness along the frame rail on the driver's side of the truck and up the firewall inside the engine compartment to the grommet of the wire harness on the driver's side of the firewall..
7. Pull the wires through the grommet into the cab.
8. **2005-2007: 2 door models** - remove the driver's side kick panel inside the cab and locate the wire harness leading to the driver's side door. Locate the Blue/Pink and the Blue/White wires. Attach the two blue wire taps to them and squeeze them shut with a pair of pliers.  
**4 door models** - run the wires up and into the driver's side rear step plate and into the 'B' pillar. Wire colors are as above.  
**2008 models** - locations are as above, however wire colors are **Blue/pink striped** and **Blue/red striped**.  
**2010 & Up** - locations are as above, however wire colors are **Blue/red** and **blue/black**.
9. Connect the long wiring harness to the blue wire taps and test the system. Lock and unlock the doors using the power door lock switch. The locking bolt of the power tailgate lock should slide below the flange of the scissor link and lock and unlock it. Reverse the wiring if the operation is out of phase.
10. Coil and tie the excess wiring harness and attach the harness to the underside of the truck with the cable ties. Make sure it isn't chafing on the springs or shocks and isn't touching any part of the exhaust system.
11. Perform a final check to see that the POWER LOCK is functioning properly and replace the access panel and the kick plate to complete the installation.

## LIMITED WARRANTY TERMS AND CONDITIONS

- (1) **Installation.** Pop & Lock™, LLC (and Pop & Lock™ Corporation) is not responsible for installing the Pop & Lock™ or for the harm suffered by any person as a result installing it.
- (2) **Warranties.**
- a. Customer acknowledges that it is unreasonable to believe that any device whatever will prevent a theft in the case of every attempt and that the most that can be expected from a so-called anti-theft or security device is that it will deter many thieves.
  - b. **POP & LOCK™ LLC. (and Pop & Lock™ Corporation) MAKES, AND CUSTOMER RECEIVES, NO WARRANTY, EXPRESSED OR IMPLIED, EXCEPT THE WARRANTIES OF TITLE TO THE POP & LOCK™ AND THEIR MERCHANTABILITY, PARTICULARLY NO WARRANTY OF FITNESS FOR A PARTICULAR USE OR PURPOSE OR AGAINST INFRINGEMENT.**
  - c. As Customer's only remedy, Pop & Lock™, LLC (and Pop & Lock™ Corporation) will repair or replace, at its option and without charge, any lock that is defective in material or workmanship when received by Customer and is returned to Pop & Lock™ LLC (and Pop & Lock™ Corporation), FOB Pop & Lock™ Corporation's offices, within one (1) year after it's receipt by the Customer. Pop & Lock LLC will ship all replacement, or repaired, Locks to Customer, FOB Pop & Lock™'s shipping point.
  - d. Factory support is only available for Pop & Lock™ products purchased as **new** through an Authorized Pop & Lock™ dealer.  
***Please Note: Pop & Lock™ Products purchased on auction sites such as Ebay, Amazon and Craigslist, to name a few, will not be covered under factory warranty under any circumstance. Pop & Lock™, LLC (and Pop & Lock™ Corporation) is unable to verify whether products sold through Auction Sites are new, used, or refurbished, and as such, Pop & Lock, LLC (and Pop & Lock™ Corporation) is unable to warranty such purchases. Pop & Lock, LLC advises using extreme caution when buying through auction sites as you'll be doing so at your own risk.***
- (3) **No Liability.** Pop & Lock™ Corporation is not liable for any loss or damage claimed by Customer or any third person to have been suffered or incurred as a result or, or related to, the Locks purchased under this Agreement, regardless of the circumstances or form of action, except any bodily injury or death for which Pop & Lock™ is liable under products-liability law. Without limiting the generality of the foregoing, in no event will Pop & Lock™ LLC be liable to Customer for any indirect, special, or consequential damages, regardless of the circumstances or the cause of action, particularly not for the value of a vehicle, or any other money damages in the event that a tailgate is stolen either notwithstanding the use of a Pop & Lock™ or when it has been returned for repair or replacement.