

POWER TAILGATE LOCK

Instructions Model PL8340

DODGE RAM 1500, 2002 to 2008

DODGE RAM 2500 and 3500, 2003 to 2009

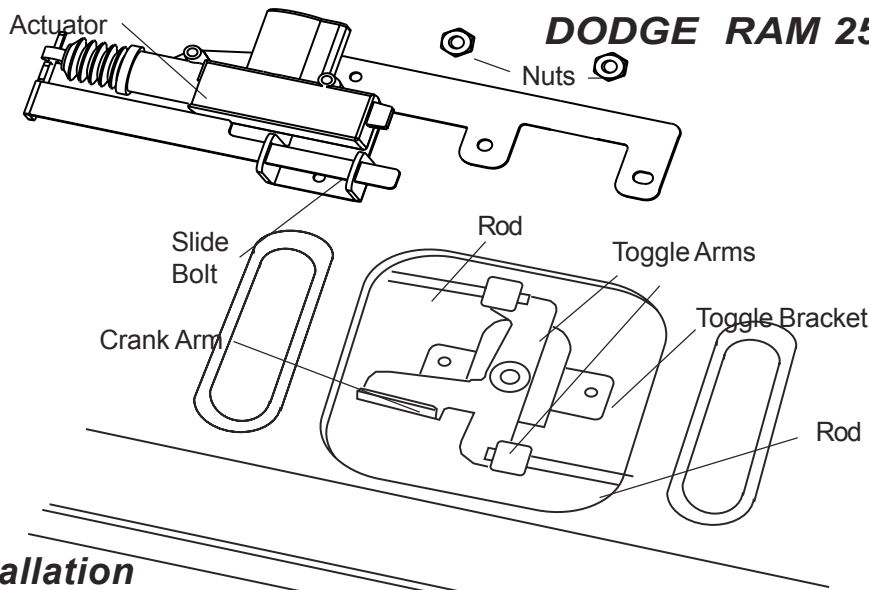

Parts Included:

Power Tailgate Lock Unit
Short Wiring Cable
Long Wiring Cable
Relay Harness
Cable Ties
Blue Connector Taps

Tools Required:

Number 30 Torx Driver
8 mm Socket
Pliers
Small Screwdriver

Installation

1. Test the system by connecting the POWER LOCK to the short and the long wiring harness and take it forward into the cab to test wire it.
2. **WIRING:** Remove the driver's side kick panel and locate the wiring harness leading to the driver's side door. Locate the **tan/pink striped** and the **Tan/2 Orange stripes** wires located along the firewall and the parking brake. Attach the two blue wire taps to them and squeeze them shut with a pair of pliers.

NOTE: '04 Models - wires are **tan/light green striped** and **light green** located in the drivers step plate and kick panel.

'05 to '09 Models - wires are **tan/2 green stripes** and **solid green** or **light green**, or **tan/pink stripe** and **tan/2 orange stripes**.

3. Connect the long wiring harness to the blue wire taps and test the system. Lock and unlock the doors using the power door lock switch. You can now unplug the wires from the blue leads.
4. Lower the tailgate, remove the access panel that is held on by 10 screws.
5. Release the rod ends from the toggle arms, remove the two nuts holding the toggle bracket.
6. Place the POWER LOCK inside the tailgate with the actuator on the driver's side on top of the toggle bracket and secure it with two nuts as shown. The slide bolt should slide below the crank arm in the locked or contracted position.
7. Connect the rod ends into the toggle arms.
8. Feed the round bullet connectors on the end of the short wiring cable into a drain hole at the bottom of the tailgate and up the tailgate to the handle opening. Connect them to the wires of the power tailgate lock.
9. Route the end of the short cable from the tailgate between the bumper and the truck bed.
10. Connect the short wire harness to the long wire harness. Locate the connector so that you can reach it to remove the tailgate. Coil and tie the extra length of the short wiring harness inside the tailgate. Do not attach it to the truck.
11. Route the long wire harness along the frame rail and the existing wiring on the driver's side of the truck. Use cable ties to attach the harness to the existing wiring underneath the truck. Follow the existing wiring under the cab and up to the firewall.
12. Attach the Relay Harness to the firewall close to the battery using tie-wraps. Connect the long harness from Step 11 to the **green** and **blue** wires of the Relay Harness. Route the **grey** and **purple** wires of the Relay Harness to the grommet at the hood release cable.
13. Pull the wires from step 12 through the grommet and connect them to the blue connectors you attached to the wiring in Step 3. Next, connect the **red** wire to the **positive** terminal and the **black** wire to the **negative** terminal of the battery.
14. CLOSE THE TAILGATE. Perform a final check and reverse the wires at the blue connectors

POP & LOCK®

LIMITED WARRANTY TERMS AND CONDITIONS

- (1) **Installation.** Pop & Lock™, LLC (and Pop & Lock™ Corporation) is not responsible for installing the Pop & Lock™ or for the harm suffered by any person as a result installing it.
- (2) **Warranties.**
- a. Customer acknowledges that it is unreasonable to believe that any device whatever will prevent a theft in the case of every attempt and that the most that can be expected from a so-called anti-theft or security device is that it will deter many thieves.
 - b. **POP & LOCK™ LLC. (and Pop & Lock™ Corporation) MAKES, AND CUSTOMER RECEIVES, NO WARRANTY, EXPRESSED OR IMPLIED, EXCEPT THE WARRANTIES OF TITLE TO THE POP & LOCK™ AND THEIR MERCHANTABILITY, PARTICULARLY NO WARRANTY OF FITNESS FOR A PARTICULAR USE OR PURPOSE OR AGAINST INFRINGEMENT.**
 - c. As Customer's only remedy, Pop & Lock™, LLC (and Pop & Lock™ Corporation) will repair or replace, at its option and without charge, any lock that is defective in material or workmanship when received by Customer and is returned to Pop & Lock™ LLC (and Pop & Lock™ Corporation), FOB Pop & Lock™ Corporation's offices, within one (1) year after it's receipt by the Customer. Pop & Lock LLC will ship all replacement, or repaired, Locks to Customer, FOB Pop & Lock™'s shipping point.
 - d. Factory support is only available for Pop & Lock™ products purchased as new through an Authorized Pop & Lock™ dealer.
Please Note: Pop & Lock™ Products purchased on auction sites such as Ebay, Amazon and Craigslist, to name a few, will not be covered under factory warranty under any circumstance. Pop & Lock™, LLC (and Pop & Lock™ Corporation) is unable to verify whether products sold through Auction Sites are new, used, or refurbished, and as such, Pop & Lock, LLC (and Pop & Lock™ Corporation) is unable to warranty such purchases. Pop & Lock, LLC advises using extreme caution when buying through auction sites as you'll be doing so at your own risk.
- (3) **No Liability.** Pop & Lock™ Corporation is not liable for any loss or damage claimed by Customer or any third person to have been suffered or incurred as a result or, or related to, the Locks purchased under this Agreement, regardless of the circumstances or form of action, except any bodily injury or death for which Pop & Lock™ is liable under products-liability law. Without limiting the generality of the foregoing, in no event will Pop & Lock™ LLC be liable to Customer for any indirect, special, or consequential damages, regardless of the circumstances or the cause of action, particularly not for the value of a vehicle, or any other money damages in the event that a tailgate is stolen either notwithstanding the use of a Pop & Lock™ or when it has been returned for repair or replacement.