

POWER TAILGATE LOCK

Instructions

Model PL 8200 for FORD F150/F250-350 , '87- '96/'98
FORD RANGER , '93 and up
MAZDA B Series , '94 and up

Layout - Rear View:

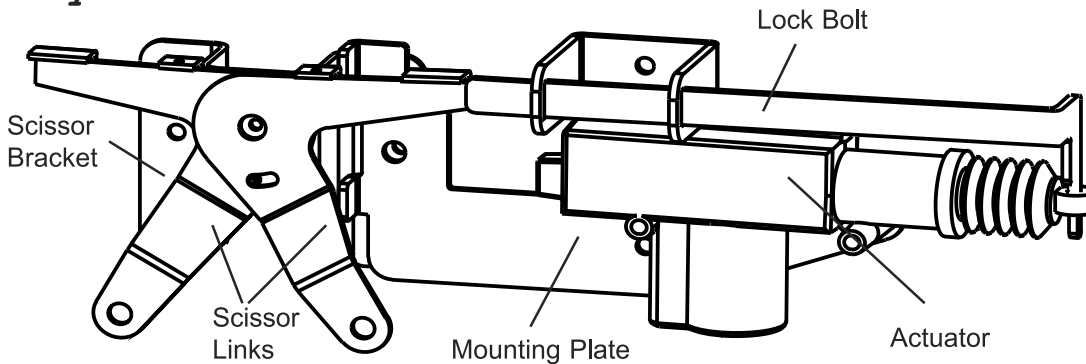

Parts Included:

Power Tailgate Lock Unit
Short Wiring Cable
Long Wiring Cable
Cable Ties
Blue Connector Taps

Tools Required:

T-30 Torx Driver
10 MM Sockethead
Phillips Screwdriver
Pliers

Installation:

1. Lower the tailgate and remove the access panel with a Torx T-30 screwdriver.
2. Release the rod ends from the scissor links, remove the two 10 MM nuts holding the scissor bracket and remove it and the handle.
3. Test the system by bolting the POWER LOCK to the handle and the scissors bracket with the two nuts, connect it to the short and the long wiring harness and take it forward into the cab to test wire it.
4. Remove the kick panel and locate the wiring harness. Locate the appropriate wires according to the following table and attach the two blue wire taps to them and squeeze them shut with a pair of pliers

1994-1996 Ford Ranger and Ford F-Series trucks and all trucks with keyless entry

Remove the passenger's side kick panel and find the wire harness with the **pink w/red** wire and the **pink w/black** wire.

All other Ford Ranger up to 2009 and Ford F-Series Trucks up to 1998

Remove the passenger's side kick panel and find the wire harness with the **pink w/orange** wire and the **pink w/black** wire.

Ford Ranger 2010 & Up

Remove the passenger's side kick panel and find the wire harness with the **white w/purple** wire and the **grey w/purple** wire.

NOTE: All 4 door models (Supercab, Super Crew, Sport Trac) have the connection point in the driver's side rear door step plate and B-pillar. The wire colors remain the same.

5. Connect the long wiring harness to the blue wire taps and test the system. Lock and unlock the doors using the power door lock switch. The locking mechanism of the power tailgate lock should lock and unlock the driver's side scissor link.. Reverse the wiring if the operation is out of phase. You can now unplug the wires from the blue leads.
6. Reinstall all the components into the tailgate. Connect the rod ends into the scissor links.
7. Feed the round bullet connectors on the end of the short wiring cable into a drain hole at the bottom of the tailgate and up the tailgate to the handle opening. Connect them to the wires of the power tailgate lock.
8. Route the end of the short cable from the tailgate between the bumper and the truck bed.
9. Connect the short wire harness to the long wire harness. Locate the connector so that you can reach it to remove the tailgate. Coil and tie the extra length of the short wiring harness inside the tailgate. Don't attach it to the truck.
10. Route the long wire harness along the frame rail and the existing wiring on the driver's side of the truck. Use cable ties to attach the harness to the existing wiring underneath the truck. Follow the existing wiring under the cab and up the firewall to the grommet at the hood-release cable.
11. Pull the wires through the grommet and lead them to the blue connectors you attached to the wiring in Step 4. The system is now fully installed. Perform a final check and reverse the wires if necessary.

POP & LOCK[®]

LIMITED WARRANTY TERMS AND CONDITIONS

- (1) **Installation.** Pop & Lock™, LLC (and Pop & Lock™ Corporation) is not responsible for installing the Pop & Lock™ or for the harm suffered by any person as a result installing it.
- (2) **Warranties.**
 - a. Customer acknowledges that it is unreasonable to believe that any device whatever will prevent a theft in the case of every attempt and that the most that can be expected from a so-called anti-theft or security device is that it will deter many thieves.
 - b. **POP & LOCK™ LLC. (and Pop & Lock™ Corporation) MAKES, AND CUSTOMER RECEIVES, NO WARRANTY, EXPRESSED OR IMPLIED, EXCEPT THE WARRANTIES OF TITLE TO THE POP & LOCK™ AND THEIR MERCHANTABILITY, PARTICULARLY NO WARRANTY OF FITNESS FOR A PARTICULAR USE OR PURPOSE OR AGAINST INFRINGEMENT.**
 - c. As Customer's only remedy, Pop & Lock™, LLC (and Pop & Lock™ Corporation) will repair or replace, at its option and without charge, any lock that is defective in material or workmanship when received by Customer and is returned to Pop & Lock™ LLC (and Pop & Lock™ Corporation), FOB Pop & Lock™ Corporation's offices, within one (1) year after it's receipt by the Customer. Pop & Lock LLC will ship all replacement, or repaired, Locks to Customer, FOB Pop & Lock™'s shipping point.
 - d. Factory support is only available for Pop & Lock™ products purchased as **new** through an Authorized Pop & Lock™ dealer.
Please Note: Pop & Lock™ Products purchased on auction sites such as Ebay, Amazon and Craigslist, to name a few, will not be covered under factory warranty under any circumstance. Pop & Lock™, LLC (and Pop & Lock™ Corporation) is unable to verify whether products sold through Auction Sites are new, used, or refurbished, and as such, Pop & Lock, LLC (and Pop & Lock™ Corporation) is unable to warranty such purchases. Pop & Lock, LLC advises using extreme caution when buying through auction sites as you'll be doing so at your own risk.
- (3) **No Liability.** Pop & Lock™ Corporation is not liable for any loss or damage claimed by Customer or any third person to have been suffered or incurred as a result or, or related to, the Locks purchased under this Agreement, regardless of the circumstances or form of action, except any bodily injury or death for which Pop & Lock™ is liable under products-liability law. Without limiting the generality of the foregoing, in no event will Pop & Lock™ LLC be liable to Customer for any indirect, special, or consequential damages, regardless of the circumstances or the cause of action, particularly not for the value of a vehicle, or any other money damages in the event that a tailgate is stolen either notwithstanding the use of a Pop & Lock™ or when it has been returned for repair or replacement.