

POWER TAILGATE LOCK

Instructions

Model PL 8110 for CHEVY SILVERADO/GMC SIERRA, 1999-2007 Classic

Layout - Rear View:

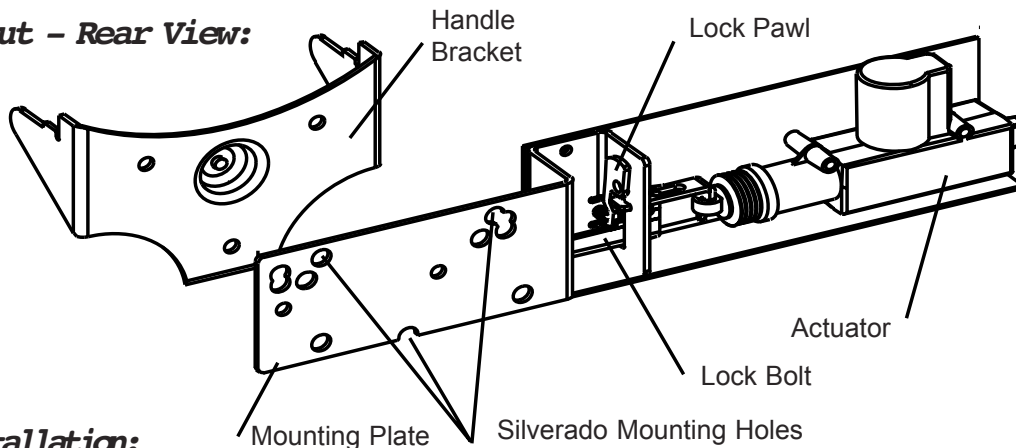

Parts Included:

Power Tailgate Lock Unit
Short Wiring Cable
Long Wiring Cable
Cable Ties
Blue Connector Taps

Tools Required:

13 MM Socket
Pliers

Installation:

1. Remove the black plastic bezel by first loosening the three 13 mm mounting bolts, then lifting the handle and sliding your hand along the inside top edge of the bezel until you feel the two plastic hooks that are 3 inches apart. Bend the tip of the hooks down until they release their hold on the tailgate. Tilt the bezel out at the top and pull it up to release the bottom hooks.
2. Lower the tailgate – FROM THIS POINT UNTIL COMPLETION DO NOT CLOSE THE TAILGATE.
3. Release the rod ends from the scissor links, remove the three screws holding the handle bracket and lift it out of the tailgate.
 4. Test the system by bolting the POWER LOCK to the handle bracket with two screws as shown, connect it to the short and the long wiring harness and take it forward into the cab to test wire it.
5. **WIRING: Model years 1998-2002:** Open the driver's side door and locate the fuse box at the left edge of the dash panel. Open the fuse box panel and locate the **gray wire** and the **tan wire** leading to a light colored relay. Attach the blue connector taps to them and squeeze them shut with the pliers.

Model years 2003-up: Refer to the enclosed wiring instructions
6. Connect the long wiring harness to the blue wire taps and test the system. Lock and unlock the doors using the power door lock switch. The locking mechanism of the power tailgate lock should lock and unlock the handle. The Lock Pawl should drop into the notch of the Lock Bolt to hold it in the locked position. Reverse the wiring if the operation is out of phase. You can now unplug the wires from the blue connector taps.
7. Feed the round bullet connectors on the end of the short wiring cable into a drain hole at the bottom of the tailgate and up the tailgate to the handle opening. Connect them to the wires of the power tailgate lock.
8. Place the power tailgate lock inside the tailgate with the actuator on the driver's side.
9. Replace the handle in the tailgate. Align the holes of the handle with the specified holes (see photo above), the power lock, and the tailgate and reinstall the three mounting screws.
10. Connect the rod ends into the scissor links and snap the plastic bezel into place.
11. Route the end of the short cable from the tailgate between the bumper and the truck bed.
12. Connect the short wire harness to the long wire harness. Locate the connector so that you can reach it to remove the tailgate. Coil and tie the extra length of the short wiring harness inside the tailgate. Don't attach it to the truck.
13. Route the long wire harness along the frame rail and the existing wiring on the driver's side of the truck. Use cable ties to attach the harness to the existing wiring underneath the truck. Follow the existing wiring under the cab and up the firewall to the grommet at the hood-release cable.
14. Pull the wires through the grommet and lead them to the blue connectors you attached to the wiring in Step 5. The system is now fully installed. CLOSE THE TAILGATE. Perform a final check and reverse the wires if necessary.

PL8110 2003 AND UP ONLY CHEVY & GMC SIERRA REVISED ELECTRICAL CONNECTION INSTRUCTIONS

ATTENTION:

DO NOT REMOVE SWITCH CONTROL PANEL AS THERE IS A SCREW HOLDING IT IN PLACE INSIDE THE DOOR PANEL.

DO NOT TAP INTO TAN & GRAY WIRES UNDER THE DASH AS THEY ARE SPEAKER WIRES.

DISCONNECT BATTERY TERMINAL.

TOOLS NEEDED: 7MM NUT DRIVER; FLAT (STANDARD) SCREW DRIVER; KNIFE, PLIERS



1. REMOVE MANUALLY OPERATED LOCK LEVER.
GENTLY PRY BOTH SIDES OFF. USE CAUTION NOT TO BREAK TABS.
2. REMOVE 7MM BOLT BEHIND LEVER

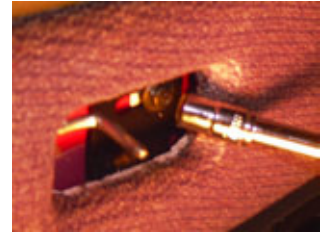

3. REMOVE 7MM BOLT BEHIND THE HANDLE ON THE ARM REST



4. REMOVE PLASTIC COVER FROM AROUND DOOR HANDLE BY GENTLY PRYING IT OFF STARTING FROM LOWER LEFT TO RIGHT

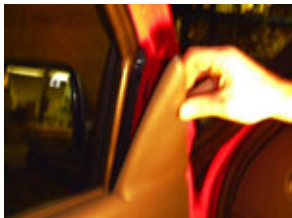

5. REMOVE THE TRIANGULAR PLASTIC PANEL (NEAR SIDE MIRROR; TOP RIGHT OF DOOR PANEL) BY PULLING FROM THE TOP



6. GENTLY LIFT DOOR PANEL STRAIGHT UP FROM THE BOTTOM EDGE AND ARM REST

7. AFTER THE DOOR PANEL IS REMOVED, GENTLY DISCONNECT THE WIRES FROM THE SWITCH PANEL & COURTESY LIGHT

PL8110 REVISED ELECTRICAL CONNECTION INSTRUCTIONS (Cont'd)



8. REMOVE STEP SILL BY GENTLY PRYING UP (LEFT PICTURE)
9. REMOVE KICK PANEL BY GENTLY PULLING STRAIGHT OUT (RIGHT PICTURE)

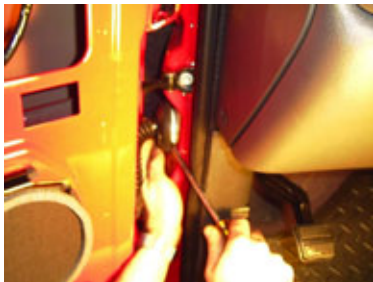
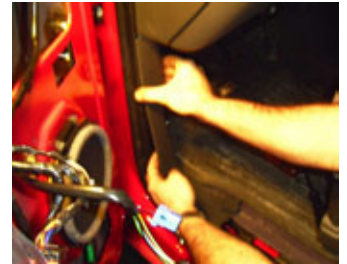

10. PULL THE POP&LOCK WIRING HARNESS INTO THE SILL AND ROUTE INTO THE DRIVERS' SIDE KICK PANEL. RUN THE WIRES FROM THE POP & LOCK THROUGH RUBBER BOOT TO DRIVER SIDE DOOR. RUBBER BOOT IS EASILY REMOVED WITH SCREWDRIVER

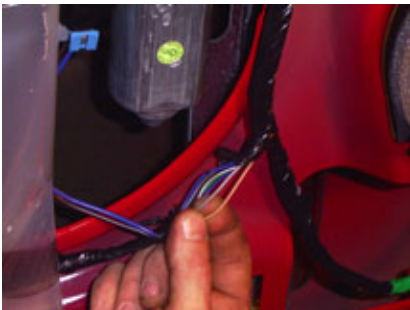

11. LOCATE TAN & GRAY WIRES IN HARNESS DIRECTLY BELOW POWER WINDOW MOTOR. ATTACH THE 2 BLUE WIRE TAPS TO THEM & SQUEEZE THEM SHUT WITH A PAIR OF PLIERS. CONNECT THE LONG WIRING HARNESS TO THE BLUE WIRE TAPS & TEST THE SYSTEM. REVERSE WIRES IF THE OPERATION IS OUT OF PHASE.

12. REASSEMBLE THE DOOR PANEL.

LIMITED WARRANTY TERMS AND CONDITIONS

- (1) **Installation.** Pop & Lock™, LLC (and Pop & Lock™ Corporation) is not responsible for installing the Pop & Lock™ or for the harm suffered by any person as a result installing it.
- (2) **Warranties.**
- a. Customer acknowledges that it is unreasonable to believe that any device whatever will prevent a theft in the case of every attempt and that the most that can be expected from a so-called anti-theft or security device is that it will deter many thieves.
 - b. **POP & LOCK™ LLC. (and Pop & Lock™ Corporation) MAKES, AND CUSTOMER RECEIVES, NO WARRANTY, EXPRESSED OR IMPLIED, EXCEPT THE WARRANTIES OF TITLE TO THE POP & LOCK™ AND THEIR MERCHANTABILITY, PARTICULARLY NO WARRANTY OF FITNESS FOR A PARTICULAR USE OR PURPOSE OR AGAINST INFRINGEMENT.**
 - c. As Customer's only remedy, Pop & Lock™, LLC (and Pop & Lock™ Corporation) will repair or replace, at its option and without charge, any lock that is defective in material or workmanship when received by Customer and is returned to Pop & Lock™ LLC (and Pop & Lock™ Corporation), FOB Pop & Lock™ Corporation's offices, within one (1) year after it's receipt by the Customer. Pop & Lock LLC will ship all replacement, or repaired, Locks to Customer, FOB Pop & Lock™'s shipping point.
 - d. Factory support is only available for Pop & Lock™ products purchased as **new** through an Authorized Pop & Lock™ dealer.
Please Note: Pop & Lock™ Products purchased on auction sites such as Ebay, Amazon and Craigslist, to name a few, will not be covered under factory warranty under any circumstance. Pop & Lock™, LLC (and Pop & Lock™ Corporation) is unable to verify whether products sold through Auction Sites are new, used, or refurbished, and as such, Pop & Lock, LLC (and Pop & Lock™ Corporation) is unable to warranty such purchases. Pop & Lock, LLC advises using extreme caution when buying through auction sites as you'll be doing so at your own risk.
- (3) **No Liability.** Pop & Lock™ Corporation is not liable for any loss or damage claimed by Customer or any third person to have been suffered or incurred as a result or, or related to, the Locks purchased under this Agreement, regardless of the circumstances or form of action, except any bodily injury or death for which Pop & Lock™ is liable under products-liability law. Without limiting the generality of the foregoing, in no event will Pop & Lock™ LLC be liable to Customer for any indirect, special, or consequential damages, regardless of the circumstances or the cause of action, particularly not for the value of a vehicle, or any other money damages in the event that a tailgate is stolen either notwithstanding the use of a Pop & Lock™ or when it has been returned for repair or replacement.