

Contents:

Lock Bracket, 2 keys
EL Bracket, Bolt Assembly
Instructions, Warranty Card

Tools Required:

T-30 Torx Driver, 10 MM Socket
Screw Driver

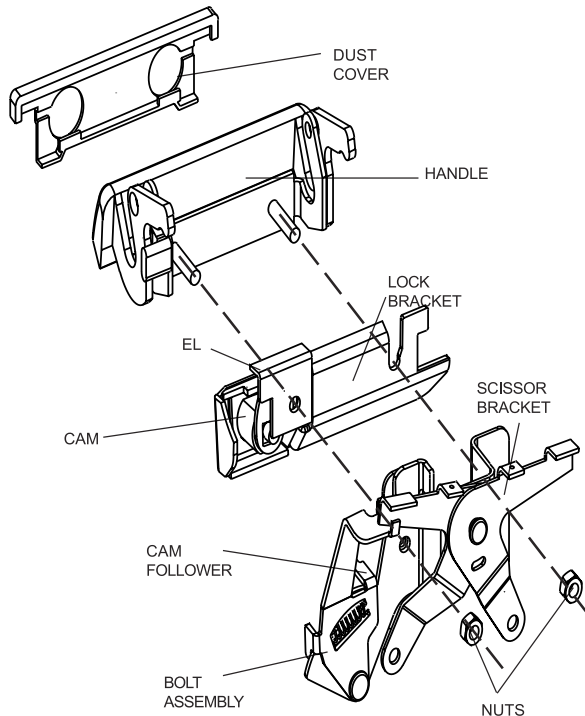

PL2300 fits trucks with a metal tailgate handle. For a plastic handle use PL2310

Installation

1. Lower the tailgate and remove the access panel with a Torx T-30 driver. Bedliner panel may have to be removed.
2. Release the rod ends from the plastic clips of the scissor links by prying the yellow clasps up with a screw driver.
3. Remove the two nuts using a 10MM wrench holding the scissor bracket and remove the scissor bracket and handle.
4. Pry the plastic dust cover from the handle and discard it.
5. Slide the LOCK BRACKET over the driver's side stud on the handle and slide the EL over the passenger's side stud of the handle. Make sure EL bracket is flush beside the lock bracket.
6. Insert them into the tailgate from the outside.
7. Insert the scissor bracket into the tailgate from the inside. Tighten it down loosely with a nut on the driver's side.
8. Turn the lock counter clockwise with the slot in the horizontal position. This is important for the next step.
9. Insert the BOLT ASSEMBLY and position it onto the passenger's side stud on top of the scissor. Secure with the other nut.
10. Turn the key and check that the CAM FOLLOWER is riding on the CAM and is completely opening and closing the BOLT.
11. If necessary, reposition the BOLT ASSEMBLY to make sure the cam follower is positioned properly.
12. Tighten the passenger's side nut.
13. Reinsert the rods. Position them so there is a 1/32 play before they pull the latches. Close the yellow clasps to lock them into place. Check for proper play. Reposition the rods if necessary. Reinstall access panel.

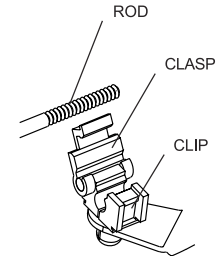

NOTE: POP&LOCK is designed to secure the passenger's side latch. You may experience that the drive side latch can open due to the flex in the handle, but the tailgate will still remain locked.

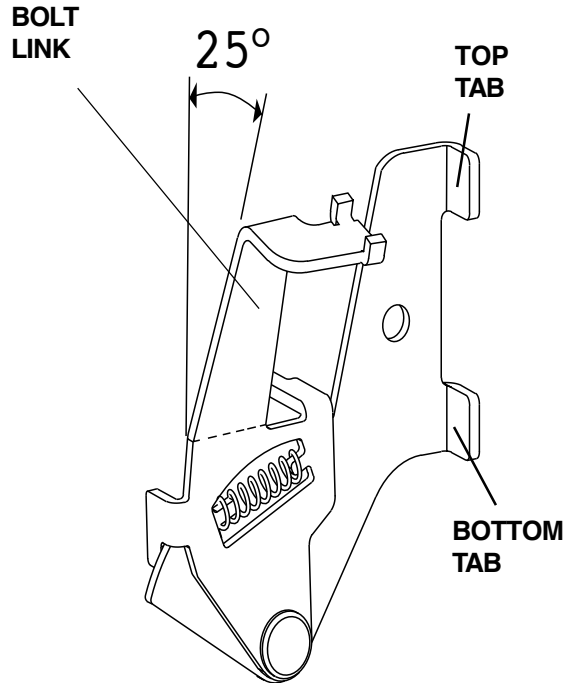

- 1.** If the BOLT LINK doesn't catch the SCISSOR LINK, then the 25° bend angle of the BOLT LINK may have to be adjusted.

Remove the spring from the BOLT ASSEMBLY, hold the BOLT ASSEMBLY in a vise, and bend the BOLT LINK along the dotted line to the desired angle.

- 2.** The amount of engagement of the BOLT LINK with the SCISSOR LINK can be adjusted by bending the TOP TAB out and the BOTTOM TAB in to increase the clearance or the opposite way to decrease the clearance.

LIMITED WARRANTY TERMS AND CONDITIONS

- (1) **Installation.** Pop & Lock™, LLC (and Pop & Lock™ Corporation) is not responsible for installing the Pop & Lock™ or for the harm suffered by any person as a result installing it.
- (2) **Warranties.**
- a. Customer acknowledges that it is unreasonable to believe that any device whatever will prevent a theft in the case of every attempt and that the most that can be expected from a so-called anti-theft or security device is that it will deter many thieves.
 - b. **POP & LOCK™ LLC. (and Pop & Lock™ Corporation) MAKES, AND CUSTOMER RECEIVES, NO WARRANTY, EXPRESSED OR IMPLIED, EXCEPT THE WARRANTIES OF TITLE TO THE POP & LOCK™ AND THEIR MERCHANTABILITY, PARTICULARLY NO WARRANTY OF FITNESS FOR A PARTICULAR USE OR PURPOSE OR AGAINST INFRINGEMENT.**
 - c. As Customer's only remedy, Pop & Lock™, LLC (and Pop & Lock™ Corporation) will repair or replace, at its option and without charge, any lock that is defective in material or workmanship when received by Customer and is returned to Pop & Lock™ LLC (and Pop & Lock™ Corporation), FOB Pop & Lock™ Corporation's offices, within one (1) year after it's receipt by the Customer. Pop & Lock LLC will ship all replacement, or repaired, Locks to Customer, FOB Pop & Lock™'s shipping point.
 - d. Factory support is only available for Pop & Lock™ products purchased as **new** through an Authorized Pop & Lock™ dealer.
Please Note: Pop & Lock™ Products purchased on auction sites such as Ebay, Amazon and Craigslist, to name a few, will not be covered under factory warranty under any circumstance. Pop & Lock™, LLC (and Pop & Lock™ Corporation) is unable to verify whether products sold through Auction Sites are new, used, or refurbished, and as such, Pop & Lock, LLC (and Pop & Lock™ Corporation) is unable to warranty such purchases. Pop & Lock, LLC advises using extreme caution when buying through auction sites as you'll be doing so at your own risk.
- (3) **No Liability.** Pop & Lock™ Corporation is not liable for any loss or damage claimed by Customer or any third person to have been suffered or incurred as a result or, or related to, the Locks purchased under this Agreement, regardless of the circumstances or form of action, except any bodily injury or death for which Pop & Lock™ is liable under products-liability law. Without limiting the generality of the foregoing, in no event will Pop & Lock™ LLC be liable to Customer for any indirect, special, or consequential damages, regardless of the circumstances or the cause of action, particularly not for the value of a vehicle, or any other money damages in the event that a tailgate is stolen either notwithstanding the use of a Pop & Lock™ or when it has been returned for repair or replacement.