



## INSTALLATION INSTRUCTIONS

### Kit Contents

Item #	Quantity Required	Description
1	1	Power Lock Assembly
2	1	Body Wire Harness
3	1	Tailgate Wire Harness
4	1	Customer Care Card
5	1	Hardware Bag
6	1	Plug and Play T-Harness

### Hardware Bag

Item #	Quantity Required	Description
2	25	10" Cable Ties
3	1	Pre-assembled fuse harness (w/ B & G connector attached)
4	1	Bolt
5	2	Wire harness grommets

### Recommended Tools

Installation Tools	
Screw Gun/Drill	Assembly Installation
10 mm socket	Negative Battery Terminal Handle Mounting Bolt
T30 "TORX" socket	Tailgate Service Hole Cover
10 mm wrench	Handle Mounting Bolt
Nylon Removal Tool	Kick Panels, Wire Harness Protector
Torque Wrench	Battery Terminal 48 in-lbs Handle Mounting Bolt 49 in-lbs
Masking Tape	

**Model PL8547TAC**  
**2016 - 2021 Toyota Tacoma**

### Legend



**STOP:** Damage to the vehicle may occur. Do not proceed until process has been complied with.



**OPERATOR SAFETY:** Use caution to avoid risk of injury.



**CRITICAL PROCESS:** Proceed with caution to ensure a quality installation. These points will be audited on a completed vehicle installation.



**TOOLS & EQUIPMENT:** This calls out the specific tools and equipment required for this process.



**SAFETY TORQUE:** This mark indicates that torque is related to safety.

### IMPORTANT WIRE ROUTING NOTE

The Plug & Play T-Harness is specific to the *Tacoma* and cannot be used for any other truck make/model. The Plug & Play T-Harness plugs into the "*IC1 10 connector ONLY*" located on the "*Driver side of the Tacoma.*" Failure to route the long harness to the proper location and proper IC1 10 connector may cause potential damage to your vehicle's electrical system which Pop & Lock is not liable for (see Warranty Terms & Conditions).

## Installation

### INSTALLATION PREPARATION:

Before starting installation

1. Familiarize yourself with the installation instructions.
2. Inspect kit components (Refer to kit contents and hardware bag contents).

### 1. VEHICLE PREPARATION



- A. **"IMPORTANT.....IMPORTANT"**  
**Disconnect and isolate negative battery cable**  
**(Fig. 1-1)**



- a) Do not come in contact with the positive terminal during the removal of the negative cable.



- B. Remove tailgate service hole cover. During disassembly take note of bolt location/size to ensure correct reinstallation. (Fig 1-2) using a T30 "TORX" socket, remove the 16 screws and service hole cover. (**NOTE:** Place the 16 screws to the side, these will be needed to reinstall service cover.) Add masking tape to all openings in tailgate around handle to cover sharp edges as shown in (Fig. 1-2)



- C. Remove and discard passenger side mounting bolt with a 10 mm socket (Fig. 1-4)

**Fig. 1-1**

-  10mm socket or wrench

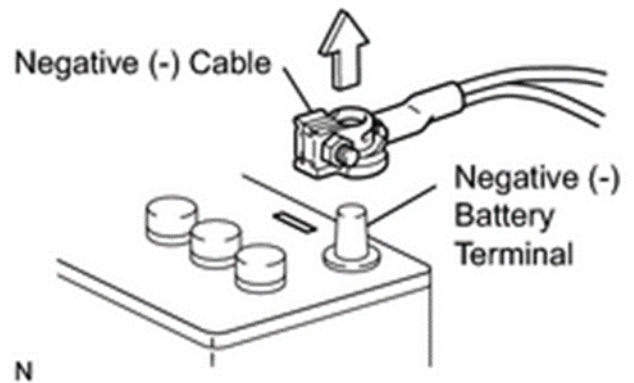

**Fig. 1-2**

-  T30 "TORX" socket

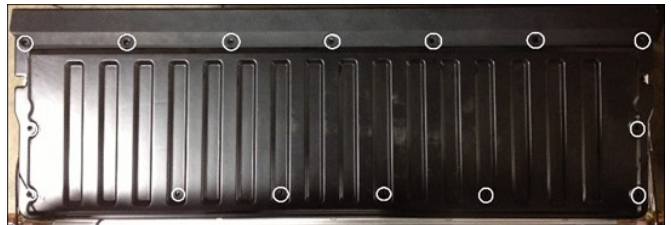

**Fig. 1-4**

-  10 mm socket or wrench

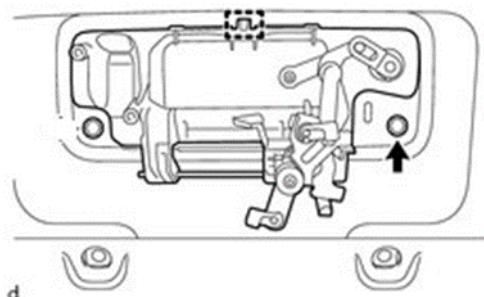

## 2. Power Lock Actuator Assembly



- A. Insert power lock assembly through second hole of sheet metal taking caution not to damage lock rod clip. (Fig. 1-5) Place the power lock assembly on to the handle. One hole in the bracket will align with the mounting bolt removed in the previous step. The other hole will surround a plastic post on the handle (Fig. 1-6A).

- B. Place the provided mounting bolt in the mounting hole of the power lock bracket. (Fig. 1-6B) and verify that the post on the lock pawl protrudes through the slot on the power lock lever arm.



- C. Tighten mounting bolt with 10mm torque wrench (49 in-lbs).



Verify latch rods and clips are still engaged.

**Fig. 1-5**



**Fig. 1-6A**

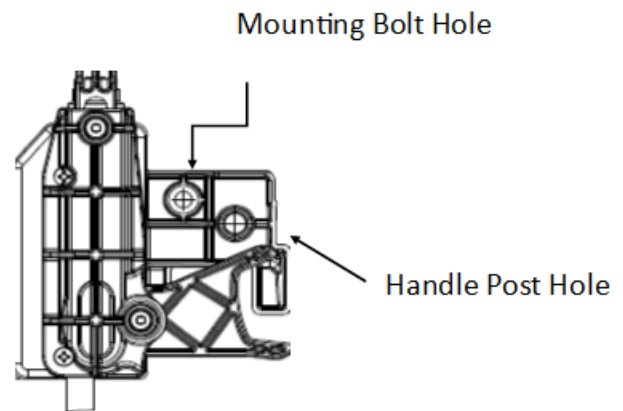

**Fig. 1-6B**



10 mm socket or wrench

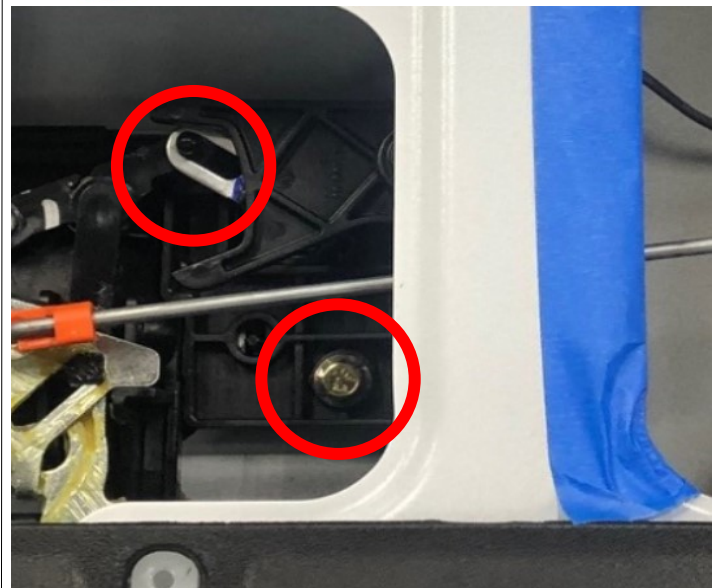



- D. Remove back up wire harness grommet from the cross member of truck bed as well as bottom of tailgate using a nylon pry tool, push in on tabs of grommet to release. Fig. 1-7 Once grommets are removed throw away.



- E. Route the tailgate wiring harness through the back-up camera access hole on both the tailgate as well as the truck bed cross member using a wire puller (Fig. 1-8). The Female connector end should be in tailgate. Pull it through one of the central cut-outs of the longitudinal stiffening panels of the tailgate. Route the power lock wire harness below the OEM camera harness. **NOTE: It is best to pull all the wire from the short harness up through the tailgate leaving only about 2 inches of wire and the Delphi plug exposed behind the truck bed cross member. This will make it easy to unplug for tailgate removal.**



- F. Using provided wire harness grommets around both camera harness and short wire harness aligning the ends of the black shrink tube with both wire harness grommets (one at each end of the black shrink tube). Snap wire harness grommets into access holes on both tailgate and truck bed cross member. **NOTE: When inserting tailgate grommet ensure the locking tab is in the same position as the removed OE grommet.** Secure wire harness to camera cable using (2) cable ties making sure to keep power lock wire harness on the OEM camera harness (Fig. 1-9). Rotate head of zip tie so it faces down.

**Fig. 1-7**



**Fig. 1-8**

Bottom of tailgate



Truck bed cross member

**Fig. 1-9**



- G.** Connect the Female Connector end of the short wire harness to the Male Connector End of actuator on the power lock. Roll up and bundle extra wire with (1) cable tie. Using (2) cable tie secure bundle to tailgate brace. Rotate head of zip tie so it faces down. (Fig. 1-10)

**Fig. 1-10**

- H.** Remove the drivers side scuff plate. (Fig. 1-11)

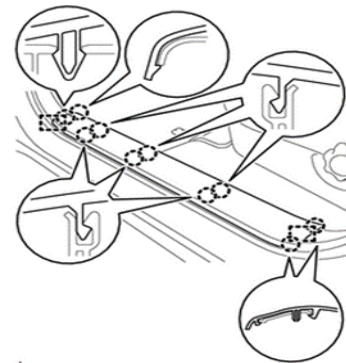

- I.** Remove the driver's side kick panel by removing the nut that holds the kick panel in place. Gently pull the panel towards you carefully not to break any of the plastic. (Fig. 1-12)

**Fig. 1-11****Fig. 1-12**



- J. Remove the drivers side rear scuff panel. Picture is the front scuff plate. Removal procedure is the same. Carefully lift carpet.



- K. Locate the "B" pillar 2" grommet behind the driver seat. Using gasket punch add a small hole in the grommet push end of body wire harness through grommet. Re-install grommet. (Fig. 1-13)

- L. From inside vehicle pull long wire harness through grommet leaving 54 inches of the harness inside of vehicle and route towards the B-pillar under the carpet. When routing the wire under the carpet follow the path pictured. (Fig. 1-14a)

Run the wire along the step sill area up into the driver side kick panel securing under factory white plastic wire holders. Secure to OEM wire harness with two cable ties; one at kick panel and one near B pillar. (Fig. 1-14b)



**\*\*Note\*\*** When securing wiring harness don't attach to the airbag harness (airbag harness identified with a yellow connector)

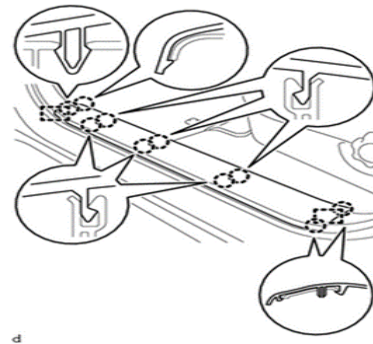

**Fig. 1-13**



**Fig. 1-14a**



**Fig. 1-14b**





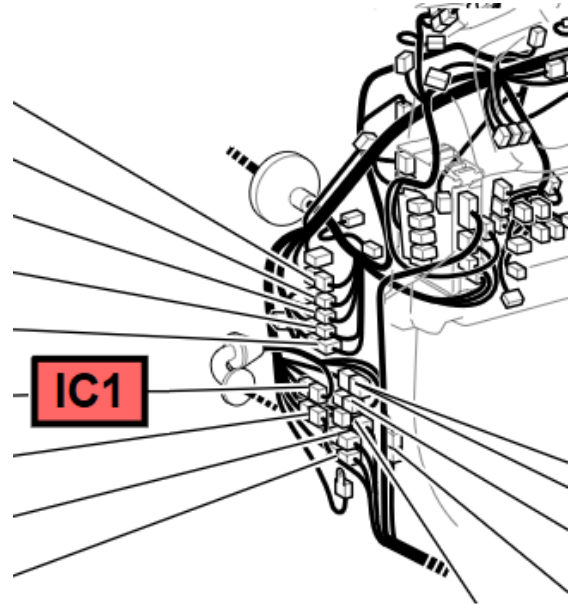
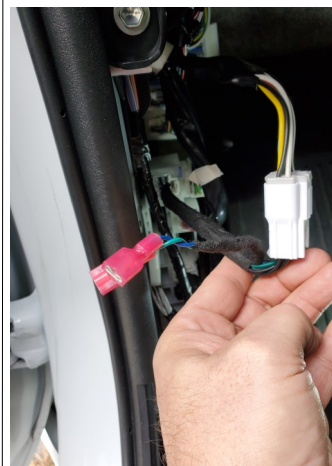

- M.** Locate the IC1 10 pin connector. Fig 1-15a  
Unplug the male factory connector from the female factory connector by pushing in clip on the side of the connector to release, then pull apart. Plug the male end of the Plug and Play T-Harness into the factory female connector. Make sure the clips locks into place. Plug the male factory connector into the female Plug and Play T-Harness. Make sure clips locks into place. Fig 1-15b  
Plug the blue and green wire male quick disconnect connectors from fuse holder harness into the female quick disconnect connectors of the plug and play t-harness. Making sure to match wire colors. Fig 1-15c  
Tuck the extra wire to the side of the factory wire plugs and secure with a cable tie. This will make installation of the kick panel easier later in the install.

**Fig. 1-15a****Fig. 1-15b****Fig. 1-15c**

- N.** Locate male connector housing on fuse harness and insert pins from long wire harness as shown in Fig 1-16.

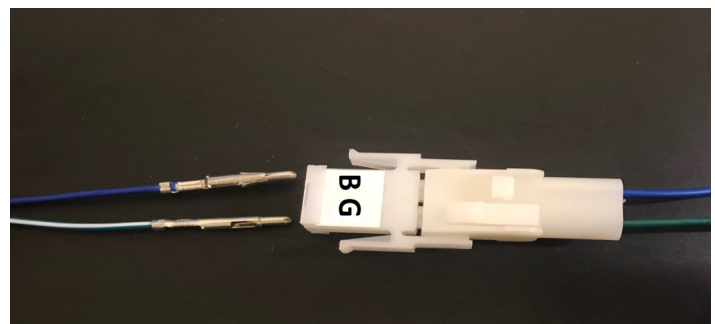
**Fig. 1-16**

- O. Route the power lock long wiring harness along the factory wire harness on the driver side towards the back of the vehicle. Use caution as the vehicle exhaust system may be hot. Secure to factory wire harness every 6 to 9 inches with cable ties. (Fig. 1-17)



**NOTE: Make sure to secure the wire so it does not touch the exhaust or get pinched.**

- P. From under the truck connect the Male end of the long wire harness to the Female end of the short harness. Bundle and secure the long wire harness under the truck bed to the camera wire harness with a cable tie maintaining easy access to the Delphi plug for tailgate removal. (Fig. 1-18) Make sure the tailgate can be open and closed without pinching any part of the connector or the wire.



**NOTE: Do not secure any part of the short harness to the actual truck or tailgate won't be able to be removed.**

**Fig. 1-17**

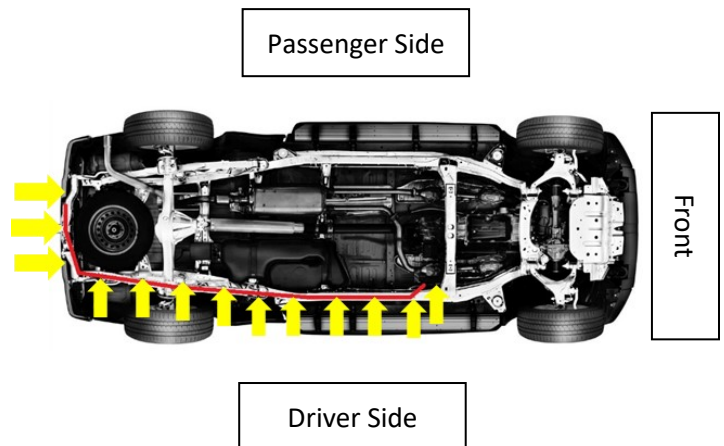

**Fig. 1-18**





## Q. Vehicle Re-Assembly

- a. Reinstall driver side kick panel
- b. Reinstall driver side scuff plate
- c. Reinstall driver side rear scuff plate
- d. Reinstall tailgate service hole cover per Fig. 1-2.
- e. Reconnect the vehicle's negative battery cable.
  - i. Position the negative battery cable at the original factory position.
  - ii. Tighten the nut with 48 in-lbs of torque.
- f. Do not come in contact with the positive terminal during the replacement of the negative cable.



## Accessory Function Test

Note: Close tailgate before beginning function test.

Step	Perform	Look For
1	Press the key FOB lock button.	The handle is locked and does not allow tailgate to open.
2	Press the key FOB unlock button once.	The handle is unlocked and allows the tailgate to open.
3	Press the vehicle lock button on door.	The handle is locked and does not allow tailgate to open.
4	Press the vehicle unlock button on door.	The handle is unlocked and allows the tailgate to open.
5	Lock the tailgate with the key.	The handle is locked and does not allow tailgate to open.
6	Unlock the tailgate with the key.	The handle is unlocked and allows the tailgate to open.
7	Rotate the driver door lock to the unlock position, return to the key-out position and rotate back to the unlock position.	The handle is unlocked and allows the door tailgate to open.
8	Rotate the key in driver door lock to the lock position	The handle is locked and doesn't allow the door tailgate to open.
9	With the vehicle in reverse and viewing the backup monitor, manually actuate power door locks to check for interference on back up monitor.	Interference on monitor.