

Contents:

Lock Assembly, 2 keys and Instructions.

Tools Required:

Philips screwdriver, Ratchet,
10 mm Socket, Ratchet extension.

Step 1: Remove the access panel from the inside of the tailgate. (You may have to remove the bed liner cover if applicable)

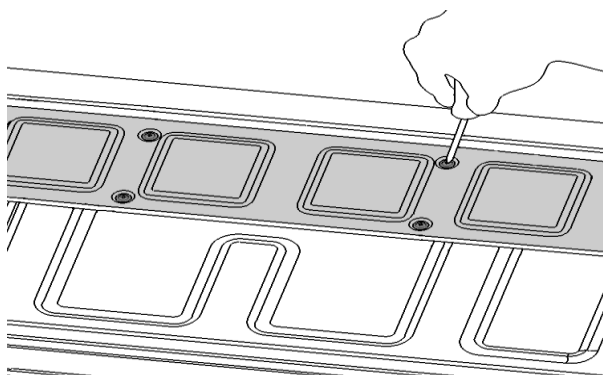

Step 2: Remove the latch rods for the factory handle by rotating of the plastic rod clips and pulling the rods up and out of the clips.

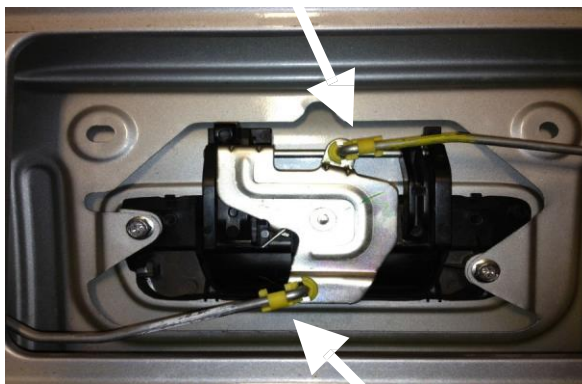

Step 3: Remove the handle mounting bolts from the factory handle.

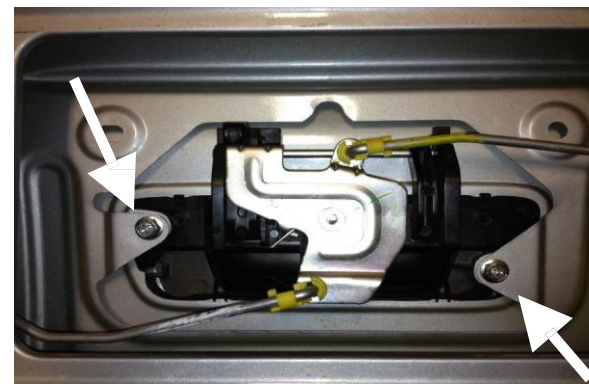

Step 4: Lift the tailgate into the up position but do not fully engage in the latches. While supporting the tailgate with one hand, pull the bottom of the handle out first, then carefully pull out the handle assembly from the top.

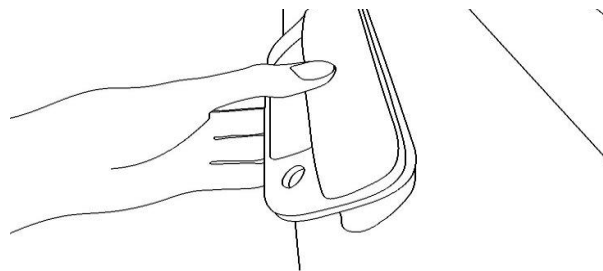

Step 5: Install the Pop & Lock into the tailgate in reverse (step 4-3-2) while making sure that it is in the locked position (fig. 1). Make sure that the bottom small tabs (fig 2) snap onto the tail-gate before tightening the bolts.

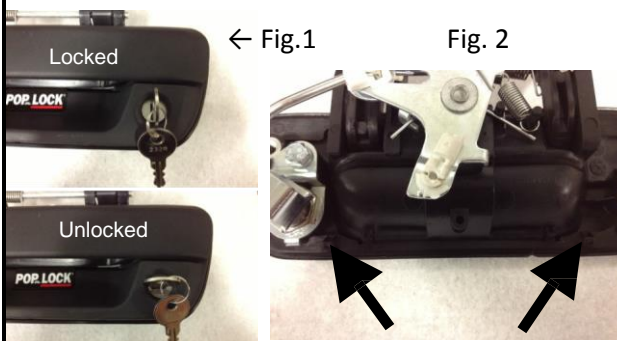

Step 6: Test the lock before installing access panel. Reinstall the access panel (and the bed liner cover if applicable).

