

polkaudio®

the speaker specialists®

PA
D5000.5

**5-CHANNEL
AMPLIFIER**

**OWNER'S
MANUAL**

TABLE OF CONTENTS

- INTRODUCTION** 3
- WHAT'S IN THE BOX** 3
- LISTEN CAREFULLY** 3
- INTERNAL BRIDGING** 3
- TOOLS OF THE TRADE** 4
- END PANEL LAYOUTS** 4 - 5
 - Line Level Inputs/Controls 4 - 5
 - Power Inputs/Speaker Outputs 5
- AMPLIFIER WIRING** 6
 - Power Connections 6
 - Speaker Wiring Diagram 6
 - Bridging 6
- AMPLIFIER INSTALLATION** 6 - 7
 - Mounting Locations 6
 - Passenger Compartment 7
 - Trunk Compartment 7
- INSTALLATION GUIDELINES** 7 - 8
- SET UP AND TROUBLESHOOTING** 8 - 10
 - Testing the System 8
 - Adjusting the Sound of the System 9
 - Troubleshooting Tips 9 - 10
- SPECIFICATIONS** 11

INTRODUCTION

Thank you for your purchase of a Polk Audio PA D Series amplifier. Each PA D Series amplifier is designed to be the leader in its class offering the most power, advanced features, and extreme ease of use. In high-end sound systems or high SPL systems, PA D Series amplifiers will give you years of trouble-free performance.

- **PA D5000.5**—100W X 4, 400W X 1, RMS @ 2 Ohms; 70W X 4, 200W X 1, RMS @ 4 Ohms
200W X 2, RMS bridged @ 4 Ohms; 500W X 1, RMS @ 1 Ohm (sub)

Note: Improper installation will not only limit the performance of your Polk Audio PA D Series amplifier but also potentially compromise the reliability of this amplifier. To ensure proper sonic results and component reliability, please refer to your authorized dealer for installation assistance or advice. If you decide to perform the installation yourself, be sure to read the entire manual before beginning the installation (see Installation Guidelines on page 7).

WHAT'S IN THE BOX

- Polk Audio Amplifier
- Remote Level Control
- Phillips Screws (8)
- Phone Line Cord
- Owner's Manual
- Terminal Block Adaptor
- Online Registration Card

Important Note: If anything is missing or damaged, or if your Polk Audio PA D Series amplifier fails to operate, notify your dealer immediately. We recommend keeping your original carton and packing materials in case you need to ship the unit in the future.

WARNING: LISTEN CAREFULLY

Polk Audio amplifiers, loudspeakers and subwoofers are capable of playing at extremely high volume levels, which could cause serious or permanent hearing damage. Polk Audio accepts no liability for hearing loss, bodily injury or property damage resulting from the misuse of its products. Keep these guidelines in mind and always use your own good judgment when controlling volume.

INTERNAL BRIDGING

Terminals that can be used in bridging mode are identified by the black and outlined boxes above each terminal. The two black boxes and the two outlined boxes work together to create an internally bridged hookup.

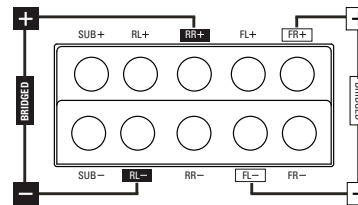

TOOLS OF THE TRADE

Listed next are the majority of the tools required to perform an installation. Having the proper tools will make the installation that much easier.

- Phillips head screwdriver
- Electric drill and 3/16" and 1/8" drill bits
- Permanent ink marker or pencil
- Safety glasses
- Wire strippers and cutters
- Electrical tape
- Amplifier Power Wire
- Solderless, crimp-on connectors and a crimping tool
- Safety glasses
- DMM or VOM
- Nylon tie straps
- Wire crimper
- Grommets for passing wires through metal car walls

END PANEL LAYOUTS

PA D5000.5 Line Level Inputs/Controls

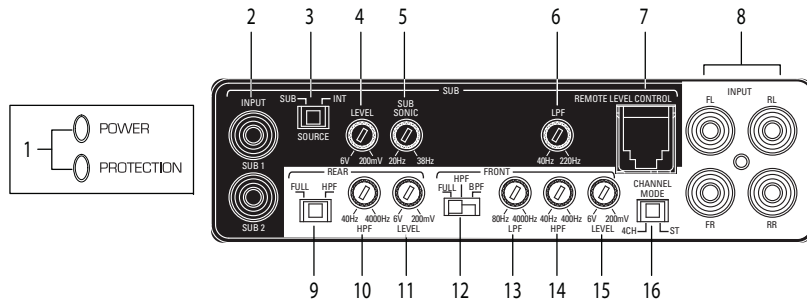

- 1. Status LEDs (on top of amplifier): Power and Protection**—Power will illuminate to indicate the amplifier is on and operating normally; Protection will illuminate if the amplifier shuts down due to short circuit, DC offset, or overheating detected by onboard protection circuitry.

Subwoofer

- 2. Sub 1/Sub2 Inputs**—Line level inputs for subwoofer signal from head unit
- 3. SUB/INT Source Switch**—Set the switch to the SUB position if you are connecting your head unit's subwoofer output to the SUB 1 or SUB 2 inputs. Set the switch to the INT position if you are sending a full range signal to the full range inputs (FL, FR, RL, RR) and not connecting anything to the SUB inputs. In the INT position, the amplifier will filter the bass frequencies from the full range signal and send them to the subwoofer amplifier channel.
- 4. Level Control**—Adjusts the gain of the subwoofer amplifier channel to match the output voltage from your head unit.
- 5. SUB Sonic Filter**—Attenuates the frequencies below the settings on the control.
- 6. LPF Control**—Adjusts the low pass filter frequency to attenuate frequencies above the setting on the control.
- 7. Remote Level Control Jack**—Connects remote bass level control.
- 8. Line Level Front/Rear Inputs**—Accepts line level input from the front and rear channels of a head unit.

Rear Controls

- 9. Rear Full, HPF Switch**—Selects between no filtering or a high pass filter. The FULL setting does not attenuate any frequencies and is for full-range speaker systems. The HPF attenuates low frequencies and is used with mid-range speakers and tweeters.
- 10. Rear HPF Control**—Adjusts the high pass filter frequency to attenuate frequencies below the setting on the control.
- 11. Rear Level Control**—Adjusts the gain of the rear channels to match the output voltage from your head unit.

Front Controls

- 12. Front FULL, HPF, BPF Switch**—Selects full range, high pass filter, or band-pass filter. The FULL setting does not attenuate any frequencies and is for full range speaker systems. The HPF setting attenuates low frequencies and is used with mid-range speakers and tweeters. The BPF setting allows you to use both the high pass filter and low pass filter, and is used with mid-range drivers.
- 13. Front LPF Control**—Adjusts the low pass filter frequency to attenuate frequencies above the setting on the control.
- 14. Front HPF Control**—Adjusts the high pass filter frequency to attenuate frequencies below the setting on the control.
- 15. Front Level Control**—Adjusts the gain of the front channels to match the output voltage from your head unit.
- 16. Channel Mode Switch (4CH/ST)**—Set the switch to 4CH if you are using four channel outputs from your head unit to the FL, FR, RL, RR inputs on the amplifier. Set the switch to ST (stereo) mode if you are using two channel outputs from your head unit. In the ST position, the amplifier will take the signal input to the FL and FR inputs and send the same signals also to the RL and RR amplifier channels.

PA D5000.5 Power Inputs/Speaker Outputs

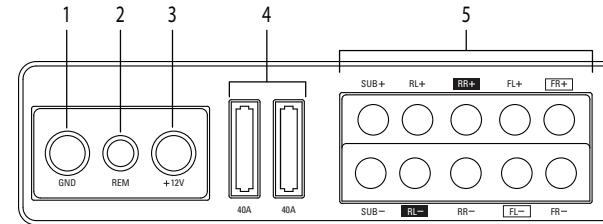

- 1. GND (Ground)**—Connect this terminal directly to the metal chassis of the vehicle, using the shortest wire necessary to make this connection. Always use wire of the same gauge or larger than the +12V power wire. The chassis connection point should be scraped free of paint and dirt. Use only quality crimped and/or soldered connectors at both ends of this wire. **DO NOT** connect this terminal directly to the vehicle battery ground terminal or any other factory ground points.
- 2. REM (Remote Turn On)**—This terminal turns on the amplifier when +12V is applied to it. Connect it to the remote turn on lead of the head unit.
- 3. +12V Power**—Connect this terminal through a **FUSE** or **CIRCUIT BREAKER** to the positive terminal of the vehicle battery or the positive terminal of an isolated audio system battery.
WARNING: Always protect this power wire by installing a fuse or circuit breaker of the appropriate size within 12" of the battery terminal connection.
- 4. Fuse**—These fuses (40A x 2) protect the amplifier against internal electrical damage and are meant to protect only the amplifier. All other power connections should be fused at the power source.
- 5. Speaker Output**—Connect the speakers here.
- 6. Terminal Adaptor**—The adaptor enables the use of cable up to 0000AWG for the ground and +12V connections (see illustration below).

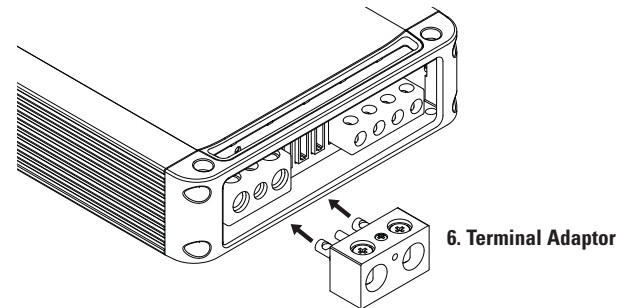

AMPLIFIER WIRING

Power Connections

- PA D5000.5 Fuse Size: 2 x 40 AMP ATC
- Power connections accept up to 4 AWG wire.
- 4 AWG power and ground wire recommended for optimal performance.
- Connect +12V to the battery through fuse holder. This connection provides +12V main power to the amplifier.
- Power wire must be fused within 12" of the battery.
- Ground the amplifier using a good chassis ground as close as possible to the amplifier.
- Connect REM terminal to remote turn-on lead from the head unit. This connection provides +12V power to turn-on the amplifier.
- Add extra ground wire between the negative terminal of the battery and the chassis.

Speaker Wiring Diagram PA D5000.5

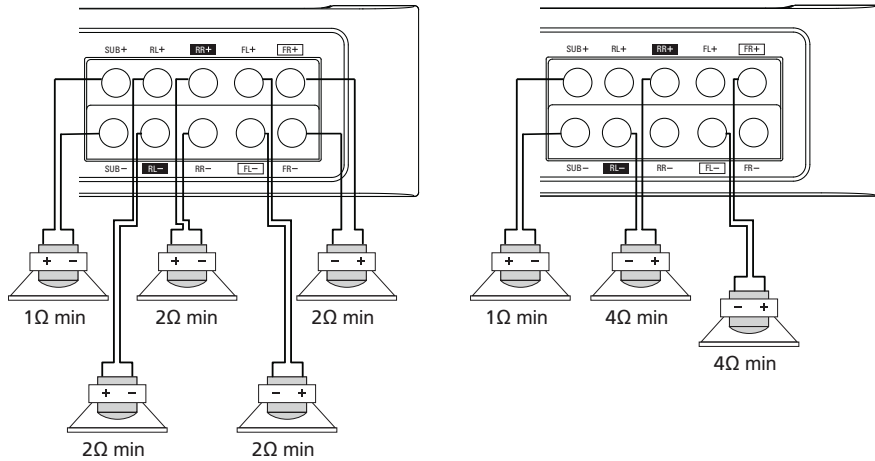

Bridging

The amplifier is capable of bridging two full range channels into a single full range channel with higher output power. For instance, the front channels (FL and FR) when wired as shown will increase the output power from 70W per channel to 200W per channel (for a 4 Ohm load). The same is true for the rear channels (RL and RR). You can do it with the front or rear channels, or both. The most common configurations are shown in the figure above: four full range channels and a subwoofer channel, or two bridged full range channels and a subwoofer channel.

Internal Bridging

Terminals that can be used in bridging mode are identified by the black and outlined boxes next to each terminal. The two black boxes and the two outlined boxes work together to create an internally bridged hookup.

AMPLIFIER INSTALLATION

Mounting Locations

The location of your amplifier will depend on several important issues. Due to the low profile and compact size of the Polk Audio PA D Series amplifier, there are many possible installation locations that will yield satisfactory amplifier performance. Always mount the amplifier in a place that protects the amplifier from the elements. In addition, mount the amplifier on a stable, flat surface.

NOTE: Mounting amplifiers upside down is not recommended and may cause premature thermal shutdown.

WARNING! DO NOT MOUNT any amplifier in the engine compartment. Amplifiers are not designed to endure the harsh environment of an engine compartment.

Passenger Compartment

If you are going to mount the amplifier in the passenger compartment, make sure you have adequate room for ventilation. When mounting your amplifier under a seat or similar area, keep a minimum of 1" of clearance around the amplifier for adequate cooling.

Trunk Compartment

Mounting your amplifier in the trunk provides excellent performance as long as you do not restrict the airflow around the heatsink of the amplifier. For optimal results, mount the amplifier with as much clearance as possible. This type of mounting will yield the best cooling due to the convection effect of the amplifier chassis.

INSTALLATION GUIDELINES

Power for systems with a single amplifier can be supplied by most automotive electrical systems. Systems with multiple amplifiers may require a higher capacity battery, alternator or the use of a storage capacitor. Polk Audio PA D Series amplifiers do generate a certain amount of heat as part of normal operation. Be sure the area around the amplifier is unobstructed to allow adequate air circulation. Remember, beach blankets, last week's laundry, school books and homework papers placed on top of the amplifier impede air flow and may cause damage.

1. Please read this owner's manual carefully before installing your amplifier.
2. Disconnect the battery ground terminal prior to making any electrical connections.
3. Check for any hazards or obstructions such as gas tanks, fuel or brake lines, and wiring harnesses before mounting the amplifier.
4. Pick a mounting location that will provide adequate access and ventilation and protect the amplifier from heat, moisture, and dirt.
5. Avoid sharp metal areas when routing cables to the amplifier, and run RCA cables away from the power cables and other potentially noisy car harnesses.
6. The amplifier should be grounded with a short, heavy gauge wire connected directly to the car at a bare metal surface, preferably scraped body metal. Do not use factory ground locations, seat bolts, or brackets that are spot welded.
7. Always fuse your power connection within 12 inches of the battery terminal. Use a fuse or circuit breaker rated slightly more than the on-board fuse(s) of the amplifier(s). The gauge of power wire used should take into account the total current draw of the system, and the length of wire used. IASCA and other auto sound competition organizations have charts available for this; you can also find a chart in the MECP study guide. Minimum wire gauge recommendations for the individual amplifiers are listed on the specification page. Always use the same gauge wire for the amplifier ground that you use for the power wire. Be sure to examine the battery ground cable of the vehicle, and if necessary, upgrade it by adding an additional ground wire that is the same gauge as the amplifier's power wire. Remember, the amplifier can only deliver its rated output when it is not current limited by the power and ground supply wires.
8. This amplifier is designed to drive a speaker load that measures from 2 to 8 Ohms for full range channels and 1 Ohm for subwoofer channel. Keep in mind that heat is the long-term enemy of automotive electronics and the lower your speaker load, the more heat is generated. For low-impedance speaker applications or restricted ventilation installations, an external cooling fan may be advisable.
9. Battery and ground connections to the vehicle should be made with crimped ring terminals of the appropriate size (surface area is what counts;) soldering the terminals after crimping is also recommended.
10. Due to the high-frequency MOSFET switching power supply, filtering the power cable is not generally required (remember that the amp can't deliver full output if the power supply is restricted.) Proper grounding of the signal source is mandatory for the amplifier to reach its performance peak. If the RCA inputs are not grounded adequately via the signal source, electrical noise from the vehicle may be picked up in the system.

Step By Step Installation

1. Determine the location for the amplifier. Refer to the Mounting Locations section of this guide.
2. Decide on the system configuration for your amplifier. For system suggestions, refer to the Speaker Wiring Diagrams section of this guide.
3. Run all the wires from the amplifier location to the speakers, source unit, and battery. Do not connect the battery at this time. Be sure to run Line levels and power and speaker wires away from factory electrical wires and system as they pose a great potential for induced system noise.
4. Pre-drill amplifier mounting holes. Be sure to “think before you drill.” Gas tanks, fuel lines, and other obstructions have a nasty way of hiding themselves. For best results use a marking pen to mark the mounting holes and pre-drill these holes with a standard 1/8" drill bit.
5. Mount the amplifier. Make sure the amplifier is mounted on a flat surface. If this is not possible, do not over tighten the screws so that the chassis of the amplifier is twisted or bent.
6. Turn the vehicle's key switch to the off position.
7. Disconnect the vehicle's battery ground terminal.
8. Connect power wires to the amplifier (ground first, then +12V and REM).
9. Connect the line level and speaker wires to the amplifier. Check the quality of your speakers and signal connections. This will determine the ultimate performance of your Polk Audio PA D Series amplifier. Refer to the Line Level Inputs/Controls and Speaker Wiring Diagrams sections of this guide for correct wiring instructions.
10. Reconnect the ground terminal to the battery after power, speaker, and line level connections are completed.
11. Set crossovers. Refer to the Line Level Inputs/Controls section of this manual for detailed instructions.
12. Once satisfied that all connections and settings are correct, install the fuse located near the vehicle's battery and proceed to the Testing the System section of this manual.

WARNING! NEVER exceed the recommended fuse size of this amplifier. Failure to do so will result in the voiding of your warranty and possible damage to the amplifier.

SET UP AND TROUBLESHOOTING

Testing the System

After you have completed the installation, you need to test the system. This will help ensure years of trouble-free operation. Please refer to the listed steps below when testing the sound of your Polk Audio PA D Series amplifier.

1. Check all the wiring connections to be sure they are correct and secure.
2. Turn the signal source volume control all the way down. Set any tone controls to their flat or defeated positions. This includes the loudness control.
3. Turn the level controls of the amplifier to their minimum positions.
4. Turn the head unit on. Check to see if the power LED located on the connection side of the amplifier is on. If not, please refer to the Power Inputs/Speaker Outputs and the Troubleshooting Tips sections of this manual for instructions.
5. If using an aftermarket head unit, turn the level controls of the amplifier about one quarter of a turn counterclockwise. Slowly increase the volume level of the head unit so that you can hear the output of the system. If no sound is heard or if the output is distorted, turn the system off immediately. Refer to the Power Inputs/Speaker Outputs and the Troubleshooting Tips sections of this manual to solve your installation problems.
6. Check to make sure the output for each channel is correct. If the active crossovers are used, check to make sure that each output is correct from the amplifier. When using active crossovers on midrange and tweeters, do not use crossover frequencies lower than recommended. If the system is not configured properly, refer to the Line Level Inputs/Controls section of this manual and take corrective action.
7. If the output is clear and undistorted, continue to the Adjusting the Sound of the System section of this manual.

Adjusting the Sound of the System

Once you have checked the system's operation, adjust the sound of the system. Adjusting the sound of the system is accomplished by setting the level controls and adjusting the internal crossovers (see Line Level Inputs/Controls on page 4).

1. Turn the signal source volume control all the way down. Set any tone controls to their flat or defeated positions. This includes the loudness control.
2. Turn the level controls of the amplifier to their minimum positions.
3. Choose music with high dynamic content that you like, with which you are familiar, and will be used most often in the system.
4. Turn the source unit's volume control up to its highest undistorted output level. If you lack test equipment, this point occurs between 3/4 to full volume depending on the quality of your head unit. Listen for any audible distortion. If any distortion is audible, reduce the volume of the head unit until you have an undistorted output. Leave the volume control at this position during your system tuning.
5. While listening to your chosen dynamic music, turn up the level control corresponding to the midrange output until you hear slight distortion and turn the level control back slightly for an undistorted output. Depending on your system, the midrange and tweeter output may be on the same output channels.
6. Turn up the level control corresponding to the tweeter output until you hear slight distortion and turn back the level control slightly for an undistorted output. Depending on your system the midrange and tweeter output may be on the same output channels.
7. Fine-tune the output level between midrange and tweeters. Refer to the Line Level Inputs/Controls section of this manual for detailed instructions.
8. Repeat Steps 5-7 for the rear speakers. If you do not have rear speakers continue to Step 10.
9. Set levels between the front and rear midrange and tweeters for optimum front/rear balance.
10. Turn up the level control corresponding to the woofer output until you hear slight distortion and turn back the level control slightly for an undistorted output.
11. Fine-tune the output level between satellite speakers and the woofers. Refer to the Line Level Inputs/Controls section of this manual for controls. Adjust the level to the bass output of the woofer to match the sonic requirements of the system.
12. Enjoy your awesome Polk Audio PA D Series amplifier.

TROUBLESHOOTING TIPS

Symptom	Probable Cause	Action To Take
No output		
	Low or no remote turn-on.	Check remote turn-on at amplifier and repair as needed.
	Fuse blown.	Check power wire's integrity and check for speaker shorts. Fix as needed and replace fuse.
	Power wires not connected.	Check power wire and ground connections and repair or replace as needed.
	Audio input not connected.	Check line level connections and repair or replace as needed.
	Speaker wires not connected.	Check speaker wires and repair or replace as needed.
	Speakers are blown.	Check system with known working speaker and repair or replace speakers as needed.
Audio cycles on and off		
	Thermal protection engages when amplifier heat sink temperature exceeds 85° C (185° F).	Make sure there is proper ventilation for amplifier and improve ventilation as needed.

TROUBLESHOOTING TIPS

Symptom	Probable Cause	Action To Take
	Loose or poor audio input.	Check line level connections and repair or replace as needed.
	Loose power connections.	Check power wires and ground connections and repair or replace as needed.
Distorted output		
	Amplifier level sensitivity set too high exceeding maximum capability of amplifier.	Readjust gain. Refer to the Adjusting the Sound of the System section of this manual.
	Impedance load to amplifier too low.	Check speaker impedance load, if below (2 Ohm, 4 Ohm bridged; 1 Ohm sub) rewire the speakers to achieve higher impedance.
	Shorted speaker wires.	Check speaker wires and repair or replace as needed.
	Speaker not connected to amplifier properly.	Check speaker wires and repair or replace as needed.
	Internal crossover not set properly for speakers.	Readjust crossovers. Refer to the Line Level Inputs/Controls section of this manual.
	Speakers are blown.	Check system with known working speakers and fix or replace as needed.
Poor bass response		
	Speakers wired with wrong polarity causing cancellation at low frequencies.	Check speaker polarity and fix as needed.
	Crossover set incorrectly.	Reset crossovers. Refer to the Line Level Inputs/Controls section of this manual.
	Impedance load at amplifier is too low.	Check speaker impedance load, if below (2 Ohm, 4 Ohm bridged; 1 Ohm sub) rewire the speakers to achieve higher impedance.
Battery fuse blowing		
	Short in power wire or incorrect wiring.	Check power wires and ground connections and repair or replace as needed.
	Fuse used is smaller than recommended.	Replace with proper fuse size.
	Actual current exceeds fuse rating.	Check speaker impedance load, if below (2 Ohm, 4 Ohm bridged; 1 Ohm sub) rewire the speakers to achieve higher impedance.
Amplifier fuse blowing		
	Fuse used is smaller than recommended.	Replace with proper fuse size.
	Impedance load at amplifier is too low.	Check speaker impedance load, if below (2 Ohm, 4 Ohm bridged; 1 Ohm sub) rewire the speakers to achieve higher impedance.
	Speaker is blown with shorted outputs.	Check system with known working speakers and fix or replace as needed.
	Actual current exceeds fuse rating.	Check speaker impedance load, if below (2 Ohm, 4 Ohm bridged; 1 Ohm sub) rewire the speakers to achieve higher impedance.

SPECIFICATIONS

Amplifier	PA D5000.5
Type	Bridgeable Class D MOSFET
Channels	5 channel
RMS Continuous Power @ 4 Ohms	70 W x 4; 200 W x 1
RMS Continuous Power @ 2 Ohms	100 W x 4; 400 W x 1
RMS Continuous Power Bridged @ 4 Ohms	200 W x 2
RMS Continuous Power 1 Ohm (Sub)	500 W x 1
Distortion at Rated Power	<0.1%
Remote Gain Control Included	Yes (sub only)
Minimum Impedance Bridged	4 Ohms
Minimum Impedance Not Bridged	2 Ohms
Minimum Impedance Subwoofer Channel	1 Ohm
Signal-to-noise Ratio	105dB
Frequency Response	20Hz-20kHz
Crossover Filter Slope (dB/octave)	12dB/octave
Front Gain Control	200mV - 6V
Filter Switch (Front)	3-position (BPF, Full, HPF)
High Pass Filter Frequency Range (Front)	40Hz - 400Hz
Low Pass Filter Frequency Range (Front)	80Hz - 4kHz

Amplifier	PA D5000.5
Filter Switch (Rear)	2-position (Full, HPF)
High Pass Filter Frequency Range (Rear)	40Hz - 4000Hz
Rear Gain Control	200mV - 6V
Line Level Inputs (y/n)	Yes
Line Level Outputs (y/n)	No
LED Power Indicator	Yes
LED Protection Indicator	Yes
Supply Voltage	10V - 16V
Fusing & Power/Type	(2) 40 Amp ATC
Power Connections	4 AWG
Ground Connections	4 AWG
Speaker Connections	12 AWG
Height	1 13/16" (46 mm)
Depth	6 3/4" (171.5 mm)
Width	13 5/16" (338.1 mm)
Width w/ Terminal Adaptor	14 1/16" (357.9 mm)
Weight	6.75 lbs (3.06 kg)