



PIT-PAL PRODUCTS

**THANK YOU FOR CHOOSING PIT PAL PRODUCTS!
YOUR PURCHASE IS GREATLY APPRECIATED!**
*Please continue to choose Pit Pals for all your organizational needs
in the trailer, shop or at the track!*

INSTALLATION INSTRUCTIONS FOR PRO ENGINE STAND Part # 162

**This unit is a great way to transport your big or small block chevy engine.
Simply assemble as shown. Locate storage area for your engine in trailer.
Mark location for locking pins. Drill two 5/8 holes.**

HARDWARE LIST

3/8 -16 x1	QTY 2
3/8 -16 x2	QTY 6
3/8 -16 x2 1/4	QTY 2
3/4 x 1/2 x 3/8 i.d.bushings	QTY 2
3/8 -16 Nylok nut	QTY 10

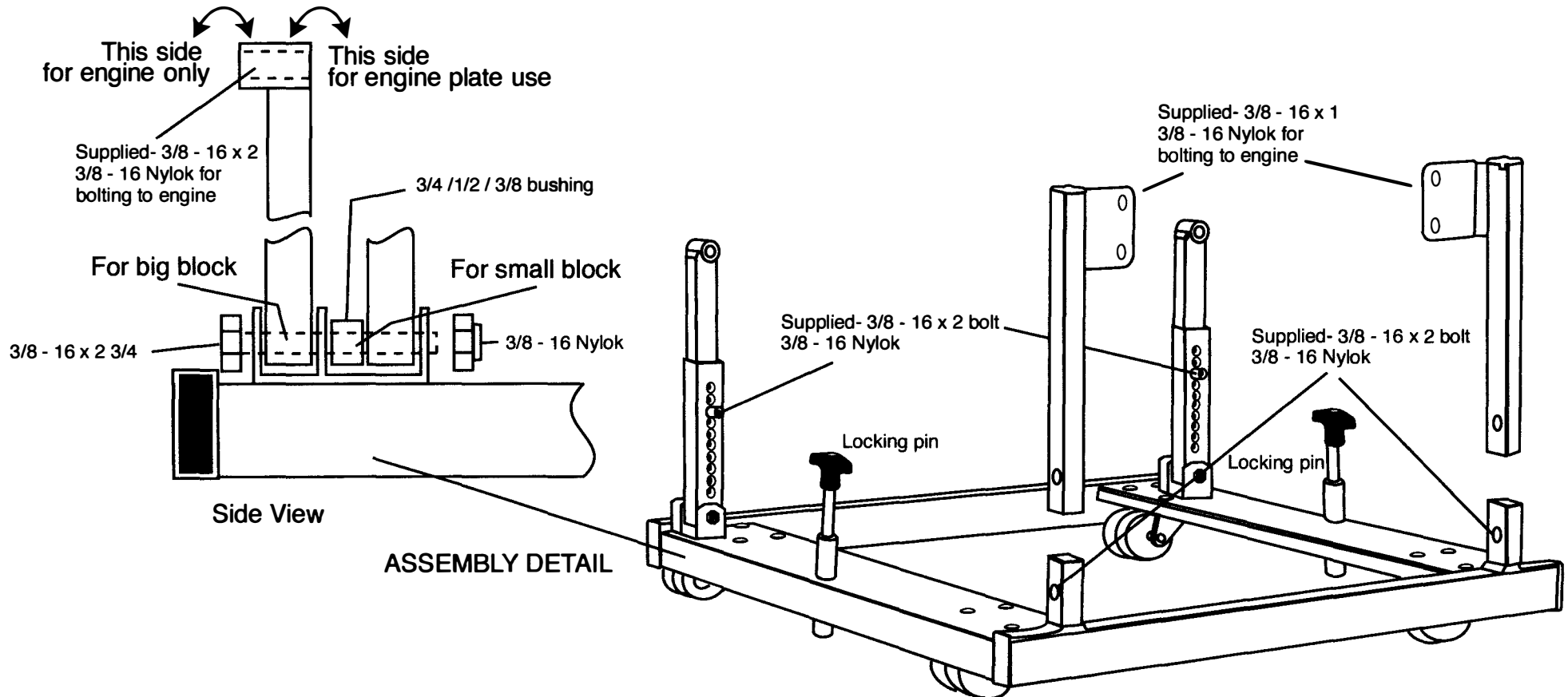

Discover other garage accessories on our website.