



Tire User Guides

Pirelli Tire Knowledge

Over one hundred years' experience of tire technology has enabled Pirelli to combine in their products maximum levels of security, longevity, comfort and attention to the environment.

Each Pirelli tire provides not only performance but also a "feel for the road" and a communication with the driver, allowing a better understanding of the vehicle's performance.

We recommend this section if you want to become familiar with the world of car tires.



ALL ABOUT TIRE'S SIZE. Tire Size Designation For:

PASSENGER CAR	European Metric Designation 185 / 70 R 14 Rim Diameter (inch) Radial Construction Ratio of Cross-Section Height to Width (%) Cross-Section Width (mm)	P-Metric Designation P 185 / 75 R 14 Rim Diameter (inch) Radial Construction Ratio of Cross-Section Height to Width (%) Cross-Section Width (mm) Passenger Car Tire
	LT Metric Designation LT 215 / 85 R 16 Rim Diameter (inch) Radial Construction Ratio of Cross-Section Height to Width (%) Cross-Section Width (mm) Light Truck Tire	Flotation Designation 31 X 10.50 R 15 LT Light Truck Tire Rim Diameter (inches) Radial Construction Nominal Cross-Section Width (inches) Overall Diameter (inches)
TEMPORARY SPARE TIRES	T 115 / 70 D 15 Rim Diameter (inch) Diagonal Construction Ratio of Cross-Section Height to Width (%) Cross-Section Width (mm) Temporary Spare Tire	



Tire Service Description

In addition to the Tire Size Designation a tire may be identified by a Service Description consisting of a **Load Index** (or two in the case of single/dual fitment) and a **Speed Symbol**.

LOAD INDEX											
LI	Kg	LI	Kg	LI	Kg	LI	Kg	LI	Kg	LI	Kg
0	45	10	60	20	80	30	106	40	140	50	190
1	46,2	11	61,5	21	82,5	31	109	41	145	51	195
2	47,5	12	63	22	85	32	112	42	150	52	200
3	48,7	13	65	23	87,5	33	115	43	155	53	206
4	50	14	67	24	90	34	118	44	160	54	212
5	51,5	15	69	25	92,5	35	121	45	165	55	218
6	53	16	71	26	95	36	124	46	170	56	224
7	54,5	17	73	27	97,5	37	127	47	175	57	230
8	56	18	75	28	100	38	130	48	180	58	236
9	58	19	77,5	29	103	39	133	49	185	59	243
60	250	70	335	80	450	90	600	100	800	110	1060
61	257	71	345	81	462	91	615	101	825	111	1090
62	265	72	355	82	475	92	630	102	850	112	1120
63	272	73	365	83	487	93	650	103	875	113	1150
64	280	74	375	84	500	94	670	104	900	114	1180
65	290	75	387	85	515	95	690	105	925	115	1215
66	300	76	400	86	530	96	710	106	950	116	1250
67	307	77	412	87	545	97	730	107	975	117	1285
68	315	78	425	88	560	98	750	108	1000	118	1320
69	325	79	437	89	580	99	775	109	1030	119	1360

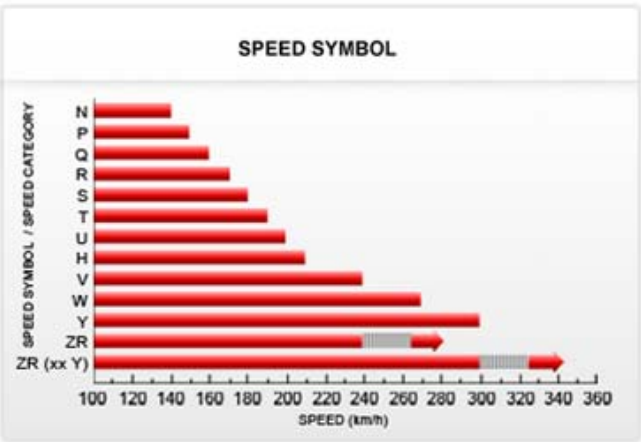

The Speed Symbol indicates the maximum speed at which the tire can carry a load corresponding to its Load Index (except for loads at speed above 210 Km/h) under service conditions specified by the tire manufacturer.

The Load Index is a numerical code associated with the maximum load a tire can carry at the maximum cold inflation pressure (except for loads at speeds above 210 Km/h) at a speed indicated its speed indicated by the speed symbol under service conditions specified by the tire manufacturer.

Discover The Tire Markings

In addition to the tire size and the service description, on the tire sidewall there are several different inscriptions: let's have a look at some of them.

Brand and Product Name





Tipo de construcción

This example shows a typical tubeless radial tire.



Side Indication

For all asymmetric products it is important to fit the tire on the rim in the correct position. In fact asymmetric tread pattern designs are developed to offer the best performance considering the different behaviours of the external and internal areas of the tread design.



DOT Safety Standard Codes

DOT (Department Of Transportation) is a legal marking required in many countries in order to sell the tyres. DOT means the tires meet or exceed the Department of Transportation's safety standards.

1. Means tire meets or exceeds Department of Transportation safety standards
2. Manufacturer and Plant Code Number (Assigned by DOT)
3. Tire Size Code Number
4. Group of Optional Symbols for the Manufacturer (To identify the brand or other significant characteristics of the tire)
5. Date of manufacture

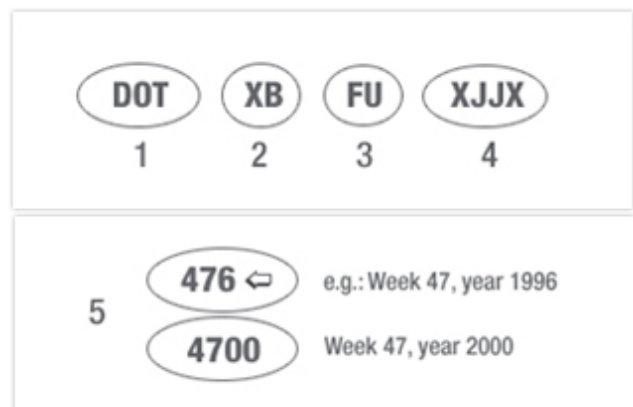



ECE Homologation

When a tire bears the ECE symbol, this means it is ECE certified and approved to meet ECE standards for physical dimensions, branding requirements and high speed endurance regulations. The marking is made up of the letter E and a number representing the country releasing the approval sheet, followed by a unique number combination for each product.



European Noise Homologation

When a tire bears the European Noise Approved number this means it is compliant with Directive 2001/43/EC, respecting the new noise emission levels set for the European countries.



U.T.Q.G.(Uniform Tire Quality Grading)

UTQG is a standard defined by the DOT of the USA for grading the performances of tires in the areas of TREADWEAR, TRACTION and TEMPERATURE RESISTANCE. It applies only to car tires with a rim diameter of 13" and larger, but not to winter tires.

TREADWEAR: The treadwear grade is a comparative rating based on the wear rate of the tire when tested under controlled conditions on a specified government test course. For example, a tire graded 150 would wear one and one-half times as well on the government course as a tire graded 100. The relative performance of tires depends upon the actual conditions of their use, however, and may depart significantly from the norm due to variations in driving habits, service practices and differences in road characteristics and climate.

TRACTION: The traction grades, from highest to lowest, are AA, A, B, and C. These grades represent the tyre's ability to stop on wet roads as measured under controlled conditions on specified government test surfaces of asphalt and concrete. A tyre marked C may have poor traction performance. Caution: the traction grade assigned to the tyre is based on straight-ahead braking traction tests, and does not include acceleration, cornering, aquaplaning, or peak traction characteristics.

TEMPERATURE: The temperature grades are A (the highest), B, and C, representing the tire's resistance to the generation of heat and its ability to dissipate heat when tested under controlled conditions on a specified indoor laboratory test wheel. Sustained high temperature can cause the material of the tire to degenerate and reduce tire life, and excessive temperature can lead to sudden tire failure. Grade C corresponds to a level of performance which all passenger car tires must meet under the Federal Motor Safety Standard No. 109. Grades B and A represent higher levels of performance on the laboratory test wheel than the minimum required by law. Caution: the temperature grade for this tire is established for a tire that is properly inflated and not overloaded. Excessive speed, under inflated tires, or excessive loads, either separately or in combination can cause heat build-up and possible tire failure.





T.W.I. (Tread Wear Indicator)

TWI is an important safety feature that easily allows how much tread is left on the tire to be verified. Narrow bars of rubber are moulded at a height of 1.6 mm (2/32") across the bottom of the tread grooves. When the tread wears down to these bars, the tire should be replaced.

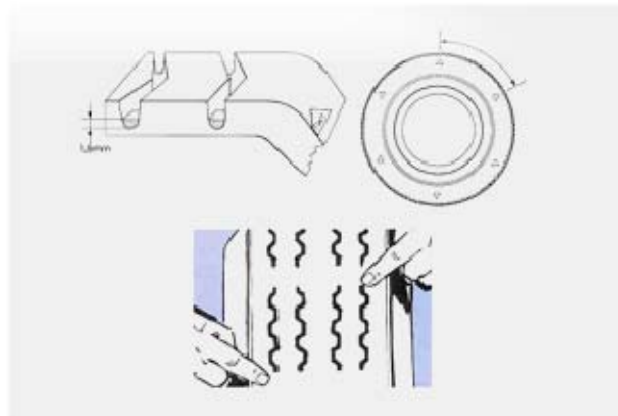

M+S (Mud & Snow) and Snowflake Marking

Winter tires, also called snow, cold weather or thermal tires, and identified by the branding M+S (Mud&Snow) on the side of the tires together with the drawing of a mountain with a snowflake. Legally the M+S marking alone is sufficient to identify a winter tyre, but the tire industry has adopted the snowflake marking to differentiate real winter tires (M+S and snowflake) from all-season tires (only M+S).

