

DVD RDS AV RECEIVER

Pioneer

DIVX

 **Bluetooth®**

DVD
VIDEO

Made for
 iPod  iPhone

 **DOLBY**
DIGITAL

AVH-X7500BT
AVH-X6500DVD

Owner's Manual

Precautions

Thank you for purchasing this PIONEER product.

To ensure proper use, please read through this manual before using this product. It is especially important that you read and observe **WARNINGS** and **CAUTIONS** in this manual. *Please keep the manual in a safe and accessible place for future reference.*

IMPORTANT SAFEGUARDS

Please read all of these instructions regarding your display and retain them for future reference.

- 1 **Do not install the display where it may (i) obstruct the driver's vision, (ii) impair the performance of any of the vehicle's operating systems or safety features, including air bags, hazard lamp buttons or (iii) impair the driver's ability to safely operate the vehicle.**
- 2 **Do not operate this display if doing so in any way will divert your attention from the safe operation of your vehicle. Always observe safe driving rules and follow all existing traffic regulations. If you experience difficulty in operating the system or reading the display, park your vehicle in a safe location and make necessary adjustments.**
- 3 **Please remember to wear your seat belt at all times while operating your vehicle. If you are ever in an accident, your injuries can be considerably more severe if your seat belt is not properly buckled.**
- 4 **Never use headphones while driving.**
- 5 **To promote safety, certain functions are disabled unless the parking brake is on, and the vehicle is not in motion.**
- 6 **Never set the volume of your display so high that you cannot hear outside traffic and emergency vehicles.**



WARNING

Do not attempt to install or service this product by yourself. Installation or servicing of this product by persons without training and experience in electronic equipment and automotive accessories may be dangerous and could expose you to the risk of electric shock, injury or other hazards.

To ensure safe driving



WARNING

- **LIGHT GREEN LEAD AT POWER CONNECTOR IS DESIGNED TO DETECT PARKED STATUS AND MUST BE CONNECTED TO THE POWER SUPPLY SIDE OF THE PARKING BRAKE SWITCH. IMPROPER CONNECTION OR USE OF THIS LEAD MAY VIOLATE APPLICABLE LAW AND MAY RESULT IN SERIOUS INJURY OR DAMAGE.**
- To avoid the risk of damage and injury and the potential violation of applicable laws, this unit is not for use with a video screen that is visible to the driver.
- To avoid the risk of accident and the potential violation of applicable laws, no viewing of front seat video should ever occur while the vehicle is being driven.
- In some countries or states the viewing of images on a display inside a vehicle even by persons other than the driver may be illegal. Where such regulations apply, they must be obeyed and this unit's video features should not be used.

When you attempt to watch a video image while driving, the warning **"Viewing of front seat video source while driving is strictly prohibited."** will appear on the front display.

To watch a video image on the front display, park your vehicle in a safe place and apply the parking brake.

Precautions

Parking brake interlock

Certain functions (Video viewing and certain touch panel keys) offered by this unit could be dangerous and/or unlawful if used while driving. To prevent such functions from being used while the vehicle is in motion, there is an interlock system that senses when the parking brake is set. If you attempt to use the functions described above while driving, they will become disabled until you stop the vehicle in a safe place, and (1) apply the parking brake, (2) release the parking brake, and then (3) apply the parking brake again. Please keep the brake pedal pushed down before releasing the parking brake.

When using a display connected to rear monitor output

The rear monitor output on this unit (**V OUT**) is used to connect a rear display that allows passengers in the rear seats to watch videos.

WARNING

NEVER install the rear display in a location where the driver can watch videos while driving.

When using the rear view camera

With an optional rear view camera, this unit can be used as an aid to keep an eye on trailers, or when backing into a tight parking spot.

WARNING

- **SCREEN IMAGE MAY APPEAR REVERSED.**
- **USE INPUT ONLY FOR REVERSE OR MIRROR IMAGE REAR VIEW CAMERA. OTHER USE MAY RESULT IN INJURY OR DAMAGE.**

CAUTION

- The rear view camera function is to be used as an aid to keep an eye on trailers, or while backing up. Do not use for entertainment purposes.
- Please note that the edges of the rear view camera images may differ slightly according to whether full screen images are displayed when backing up, and whether the images are used for checking the rear when the vehicle is moving forward.

To avoid battery exhaustion

Keep the vehicle engine running when using this unit to avoid draining the battery power.

- When no power is supplied to this unit, such as when the vehicle battery is being replaced, the microcomputer of this unit returns to its initial condition. We recommend that you transcribe the audio adjustment data.

WARNING

Do not use with vehicles that do not feature an ACC position.

Before you start

Information to User

FCC ID: AJDK062
MODEL NO.: AVH-X7500BT
IC: 775E-K062

This device complies with Part 15 of FCC Rules and Industry Canada licence-exempt RSS standard(s). Operation is subject to the following two conditions: (1) this device may not cause interference, and (2) this device must accept any interference, including interference that may cause undesired operation of this device.

This transmitter must not be co-located or operated in conjunction with any other antenna or transmitter.

The Bluetooth antenna cannot be removed (or replaced) by user.

This equipment complies with FCC/IC radiation exposure limits set forth for an uncontrolled environment and meets the FCC radio frequency (RF) Exposure Guidelines in Supplement C to OET65 and RSS-102 of the IC radio frequency (RF) Exposure rules. This equipment has very low levels of RF energy that it deemed to comply without maximum permissive exposure evaluation (MPE). But it is desirable that it should be installed and operated keeping the radiator at least 20 cm or more away from person's body (excluding extremities: hands, wrists, feet and ankles).

MODEL NO.: AVH-X6500DVD

This device complies with Part 15 of the FCC Rules. Operation is subject to the following two conditions:

(1) this device may not cause harmful interference, and (2) this device must accept any interference received, including interference that may cause undesired operation.

Alteration or modifications carried out without appropriate authorization may invalidate the user's right to operate the equipment.

Note

This equipment has been tested and found to comply with the limits for a Class B digital device, pursuant to Part 15 of the FCC Rules. These limits are designed to provide reasonable protection against harmful interference in a residential installation. This equipment generates, uses and can radiate radio frequency energy and, if not installed and used in accordance with the instructions, may cause harmful interference to radio communications. However, there is no guarantee that interference will not occur in a particular installation. If this equipment does cause harmful interference to radio or television reception, which can be determined by turning the equipment off and on, the user is encouraged to try to correct the interference by one or more of the following measures:

- Reorient or relocate the receiving antenna.
- Increase the separation between the equipment and receiver.
- Connect the equipment into an outlet on a circuit different from that to which the receiver is connected.
- Consult the dealer or an experienced radio/TV technician for help.

Before you start

The Safety of Your Ears is in Your Hands

Get the most out of your equipment by playing it at a safe level—a level that lets the sound come through clearly without annoying blaring or distortion and, most importantly, without affecting your sensitive hearing. Sound can be deceiving. Over time, your hearing “comfort level” adapts to higher volumes of sound, so what sounds “normal” can actually be loud and harmful to your hearing. Guard against this by setting your equipment at a safe level BEFORE your hearing adapts.

ESTABLISH A SAFE LEVEL:

- Set your volume control at a low setting.
- Slowly increase the sound until you can hear it comfortably and clearly, without distortion.
- Once you have established a comfortable sound level, set the dial and leave it there.

BE SURE TO OBSERVE THE FOLLOWING GUIDELINES:

- Do not turn up the volume so high that you can't hear what's around you.
- Use caution or temporarily discontinue use in potentially hazardous situations.
- Do not use headphones while operating a motorized vehicle; the use of headphones may create a traffic hazard and is illegal in many areas.

About this unit

The tuner frequencies on this unit are allocated for use in North America. Use in other areas may result in poor reception.



WARNING

Handling the cord on this product or cords associated with accessories sold with the product may expose you to chemicals listed on proposition 65 known to the State of California and other governmental entities to cause cancer and birth defect or other reproductive harm. **Wash hands after handling.**

CAUTION:
USE OF CONTROL OR ADJUSTMENT OR PERFORMANCE OF PROCEDURES OTHER THAN THOSE SPECIFIED HEREIN MAY RESULT IN HAZARDOUS RADIATION EXPOSURE.

CAUTION:
THE USE OF OPTICAL INSTRUMENTS WITH THIS PRODUCT WILL INCREASE EYE HAZARD.

CAUTION

This product is a class 1 laser product classified under the Safety of laser products, IEC 60825-1:2007, and contains a class 1M laser module. To ensure continued safety, do not remove any covers or attempt to gain access to the inside of the product. Refer all servicing to qualified personnel.

CLASS 1 LASER PRODUCT

CAUTION—CLASS 1M VISIBLE AND INVISIBLE LASER RADIATION WHEN OPEN, DO NOT VIEW DIRECTLY WITH OPTICAL INSTRUMENTS.

Before you start



CAUTION

- Do not allow this unit to come into contact with liquids. Electrical shock could result. Also, damage to this unit, smoke, and over-heating could result from contact with liquids.
- Keep this manual handy for future reference.
- Always keep the volume low enough to hear outside sounds.
- Avoid exposure to moisture.
- If the battery is disconnected or discharged, any preset memory will be erased.

Important (Serial number)

The serial number is located on the bottom of this unit. For your own security and convenience, be sure to record this number on the enclosed warranty card.

DVD video disc region numbers

Only DVD video discs with compatible region numbers can be played on this player. You can find the region number of the player on the bottom of this unit and in this manual (refer to *Specifications* on page 60).

About this manual

- This unit features a number of sophisticated functions to ensure superior reception and operation. All the functions have been designed for the easiest possible use, but many are not self-explanatory. This operation manual will help you benefit fully from this unit's potential and to maximize your listening enjoyment.
- This manual uses diagrams of actual screens to describe operations. However, the screens on some units may not match those shown in this manual depending on the model used.

- In the following instructions, USB memory sticks and USB audio players are collectively referred to as “USB storage device”.
- In this manual, iPod and iPhone will be referred to as “iPod”.

After-sales service for Pioneer products

Please contact the dealer or distributor from where you purchased this unit for after-sales service (including warranty conditions) or any other information. In case the necessary information is not available, please contact the companies listed below:
 Please do not ship your unit to the companies at the addresses listed below for repair without advance contact.

For warranty information please see the Limited Warranty sheet included with this unit.

Visit our website

Visit us at the following site:

Before you start

- 1 Register your product. We will keep the details of your purchase on file to help you refer to this information in the event of an insurance claim such as loss or theft.
- 2 Receive updates on the latest products and technologies.
- 3 Download owner's manuals, order product catalogues, research new products, and much more.
- 4 Your feedback is important in our continual effort to design and build the most advanced, consumer-focused product in the industry.

Protecting your unit from theft

The front panel can be detached to deter theft.

Important

- Handle the front panel with care when removing or attaching it.
- Avoid subjecting the front panel to excessive shock.
- Keep the front panel out of direct sunlight and high temperatures.
- If removed, replace the front panel on the unit before starting up your vehicle.
- To avoid damaging the device or vehicle interior, remove any cables and devices attached to the front panel before detaching it.

Removing the front panel

- **Pinch the top and bottom of its right side and pull the front panel out.**

Take care not to pinch it too tightly or to drop it, and also avoid contact with water or other fluids to prevent permanent damage.

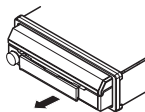

Re-attaching the front panel

- 1 **Slide the front panel to the left.**

The front panel and the head unit are connected on the left side. Make sure that the front panel has been properly connected to the head unit.

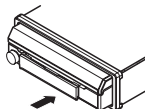

- 2 **Press the right side of the front panel until it is firmly seated.**

- If you can't attach the front panel to the head unit successfully, try again. Forcing the front panel into place may result in damage.

Use and care of the remote control

Installing the battery

Slide the tray on the back of the remote control out and insert the battery with the plus (+) and minus (-) poles aligned properly.

- When using for the first time, pull out the film protruding from the tray.

Before you start

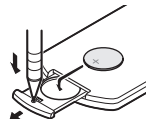

WARNING

- Keep the battery out of the reach of children. Should the battery be swallowed, consult a doctor immediately.
- Batteries (battery pack or batteries installed) must not be exposed to excessive heat such as sunshine, fire or the like.

CAUTION

- Use one **CR2025 (3 V)** lithium battery.
- Remove the battery if the remote control is not used for a month or longer.
- There is a danger of explosion if the battery is incorrectly replaced. Replace only with the same or equivalent type.
- Do not handle the battery with metallic tools.
- Do not store the battery with metallic objects.
- If the battery leaks, wipe the remote control completely clean and install a new battery.
- When disposing of used batteries, comply with governmental regulations or environmental public institutions' rules that apply in your country/area.
- *Perchlorate Material – special handling may apply.

- The remote control may not function properly in direct sunlight.

Important

- Do not store the remote control in high temperatures or direct sunlight.
- Do not let the remote control fall onto the floor, where it may become jammed under the brake or accelerator pedal.

Demo mode

The feature demo automatically starts when you select **Off** for the source and continues while the ignition switch is set to ACC or ON. To cancel the feature demo, press and hold **MUTE**. Press and hold **MUTE** again to restart. Operating the feature demo while the car engine is turned off it may drain the battery power.

Important

The red lead (ACC) of this unit should be connected to the ignition on/off function. Failure to do so may result in battery drain.

Using the remote control

Point the remote control in the direction of the front panel to operate.

What's what

Head unit

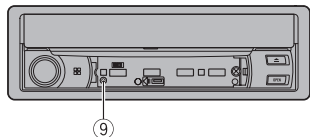
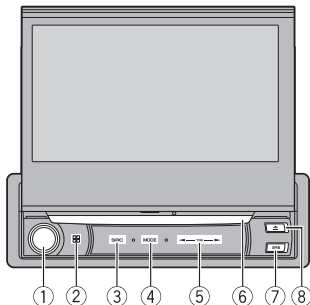

① VOLUME/MUTE

Turn **VOLUME** to adjust the volume. Press to mute. Press again to unmute.

② Home button

Displaying the home display. The display returns to the Launcher screen while a 3rd-party application is being used in **AppRadio Mode**. Double-clicking the icon on the Launcher screen returns the display to the home display.

③ SRC/OFF

④ MODE

Turning the information display off.

⑤ ◀/▶ (TRK)

⑥ Disc loading slot

⑦ OPEN/CLOSE

⑧ ▲ (eject)

⑨ RESET

For details refer to *Resetting the microprocessor* on page 39.

⚠ CAUTION

Do not use unauthorized products.

Notes

- When an iPhone is connected, press and hold the home button to activate the voice control.
- When the navigation system is connected, press **MODE** to switch to the navigation display. Press and hold **MODE** to turn the display off. Press **MODE** again to turn the display on.
- For details on how to operate a navigation system from this unit, refer to its operation manual.
- When an iPhone that is running an application that supports **AppRadio Mode** is connected, press **MODE** to switch to the application display. You can use the application by touching the display.
- For details on how to connect an iPod or USB storage device to this unit, refer to *When connecting with optional CD-IU201V cable*

What's what

Home display

Home display

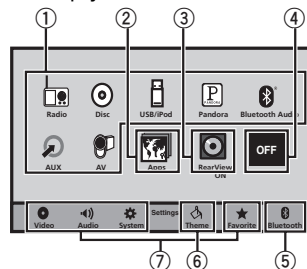

Source off display

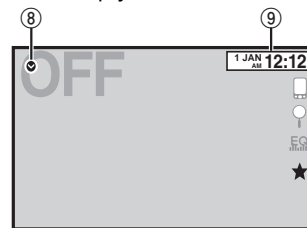

Source on display

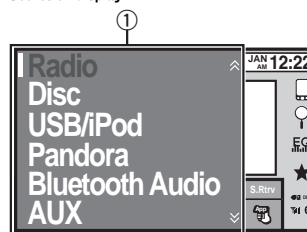

① Source icon

Selecting a favorite source. When the source icon is not displayed, it can be displayed by pressing the home key or touching .

② Apps key

Switching to **AppRadio Mode**.

③ Rear view key

Displaying the rear view image. For details refer to *Using the rear view* on page 9.

④ Source off key

Turning the source off.

⑤ Bluetooth key

Displaying the Bluetooth connection menu.

⑥ Theme key

Displaying the **Theme** menu.

⑦ Menu icon

Displaying the menu.

⑧ Source key

Displaying the source menu.

⑨ Clock key

Switching to clock adjustment display.

Turning the source ON/OFF

Turning the source on using the buttons

 Press **SRC/OFF** to turn the source on.

Turning the source off using the buttons

 Press and hold **SRC/OFF** until the source turns off.

What's what

Selecting a source

Available source modes

- **Radio** – Radio tuner
- **Disc** – Built-in DVD and CD player
- **USB/iPod** – USB/iPod
- **Pandora** – Pandora® internet radio
- **Bluetooth Audio** – Built-in Bluetooth audio (Function of AVH-X7500BT)
- **AUX** – AUX
- **AV** – AV input

Selecting a source

- Using **SRC/OFF**
 - 1 Press **SRC/OFF**.
- Using the touch panel keys on the home display
 - 1 Touch the source icon and then touch the desired source name.
 - When the source icon is not displayed, it can be displayed by touching the screen.
 - While operating the menu, you cannot select a source by touching the source icon.

Note

The **USB/iPod** icon will change as follows:

- **USB** is displayed when a USB storage device is connected to USB input.
- **iPod** is displayed when an iPod is connected to USB input.
- **USB/iPod** is displayed when no device is connected.
- **iPod** is not displayed when **RGB Input** is set to **iPhone (VGA adapter)**.
Refer to *Setting the RGB Input* on page 33.

Adjusting the volume

- Turn **VOLUME** to adjust the volume.

Remote control

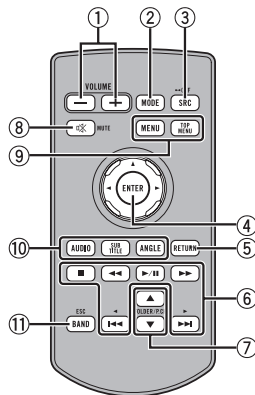

① **+/- (VOLUME)**

② **MODE**

Turning the information display off.

③ **SRC/OFF**

Refer to **Source off key** on page 7.

④ **Thumb pad**

Use to select a menu on the DVD menu.

⑤ **RETURN**

Press to display the PBC (playback control) menu during PBC playback.

⑥ **▶/||**

Press to pause or resume playback.



Press to perform fast reverse.

Press to change the fast reverse speed.



What's what

Press to perform fast forward.

Press to change the fast forward speed.



Press to return to the previous track (chapter).



Press to go to the next track (chapter).



Press to stop playback.

If you resume playback, playback will start from the point where you stopped. Touch the key again to stop playback completely.

⑦ **FOLDER/PCH**

Press to select the next or previous disc or folder.

Press to recall radio station frequencies assigned to preset channel keys.

⑧ **MUTE**

Press to mute. Press again to unmute.

⑨ **MENU**

Press to display the DVD menu during DVD playback.

TOP MENU

Press to return to the top menu during DVD playback.

⑩ **AUDIO**

Press to change the audio language during DVD playback.

Press to switch audio output for DivX/MPEG-4.

SUBTITLE

Press to change the subtitle language during DVD/DivX/MPEG-4 playback.

ANGLE

Press to change the viewing angle during DVD playback.

⑪ **BAND/ESC**

Press to select the tuner band when tuner is selected as a source. Also used to cancel the control mode of functions.

Press to switch between modes when playing the following types of data:

- **Disc**
Compressed audio and audio data (CD-DA) such as with CD-EXTRA and MIXED-MODE CDs
- **USB storage device**
Audio data

Common operations

Common operations for menu settings/lists



(Function of AVH-X7500BT)
Starting the Bluetooth telephone menu.
For details refer to *Bluetooth telephone* on page 25.



Displaying the list menu.
Starting the search function.



Displaying the EQ (Audio function menu).



Displaying the Favorite menu.

Operating the scroll icon and the scrubber bar

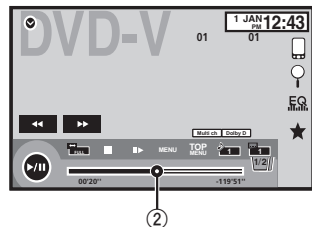
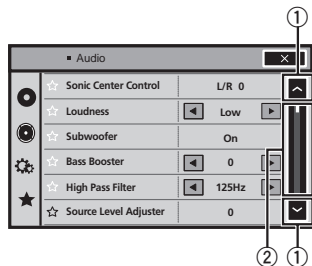

- ① **Scroll icon**
Appears when selectable items are hidden.
- ② **Scrubber bar**
Appears when items cannot be displayed on a single page only.

Viewing the hidden items

- ① Touch the scroll icon or drag the scrubber bar to view any hidden items.
- Also, you can drag the list to view any hidden items.

Specifying the playback point

- ① Drag the scrubber bar on the screen.
(Not available when the scrubber bar is grayed out.)

Common operations

Activating the touch panel keys

Touch panel keys

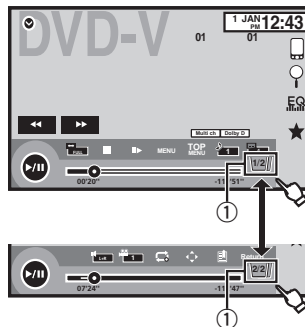

- ① **Tab key**
Switching the touch panel keys on the display.

Using the rear view

A rear view camera sold separately is required for using the rear view mode. The below functions are available.

- **Rear view camera**
This unit can be setup to display the rear view image automatically when you move the shift lever to the **REVERSE (R)** position.
- **Camera for rear view mode**
The rear view can be turned on to display at all times.
The rear view camera needs to be set to a setting other than Off to turn on rear view mode.

For details about the settings, refer to *Setting the rear view camera (back up camera)*

Using the rear view key to display the rear view

Displaying the rear view image by turning the rear view image on. When the rear view image is displayed, you can switch to the source display by touching the display. You can operate from the source display temporarily at this time. If you do not perform any operations within a few seconds, the display will return to the rear view image.

To turn off the rear view image, press the home button to return to the home display and then press this key again.



Using the rear monitor

Connecting a rear monitor, sold separately, to this unit allows images and videos to be viewed from the rear seats.

Notes

- You cannot use touch panel keys and operation screens from the rear monitor.
- Images and video will continue to be displayed whether the vehicle is in motion or stopped.

Using sound retriever

S.Rtrv

Automatically enhances compressed audio and restores rich sound.

Off — ■ — ■ — ■

- ■ — ■ is more effective than ■.

Common operations

Notes

- This function is enabled for playback on the sources listed below.
 - CD-DA
 - MP3/WMA/AAC/WAV files on USB storage devices
 - MP3/WMA/AAC files on CD media
 - iPod
 - Pandora
 This function is not available on an iPod with lightning connector or Android devices.
- The sound retriever setting is turned off when the MIXTRAX function is used in USB source mode.

- Different settings can be stored for each video source.
- When a video is viewed in a wide screen mode that does not match its original aspect ratio, it may appear different.
- Remember that using the wide mode feature of this system for commercial or public viewing purposes may constitute an infringement on the author's rights protected by the Copyright Law.
- The video image will appear coarser when viewed in **Zoom** mode.
- This function is enabled for playback on the sources listed below.
 - **Disc:** DVD-V, Video-CD, DivX, MPEG-1, MPEG-2, MPEG-4
 - **iPod:** Video
 - **AV:** A/V data
 - **AUX:** A/V data

Changing the wide-screen mode



Selecting the appropriate screen ratio for the playback video.

- 1 **Display the screen mode.**
- 2 **Touch the desired wide mode setting.**

Full (full screen)

The 4:3 picture is enlarged in the horizontal direction only, granting viewers a 4:3 TV picture (normal picture) without any omissions.

Zoom (zoom)

The 4:3 picture is enlarged in the same proportion both vertically and horizontally; ideal for a cinema sized picture (wide screen picture).

Normal (normal)

The 4:3 picture is displayed as is, granting viewers no sense of disparity as the proportions are the same as that of the normal picture.

Notes

- You cannot operate this function while driving.

Basic operations

Opening and closing the LCD panel

The LCD panel will open or close automatically when the ignition switch is turned on or off. You can turn off the automatic close/open function.

- Do not close the LCD panel by force with your hands. That will cause a malfunction.
- The automatic close/open function will operate the display as follows.
 - When the ignition switch is turned OFF while the LCD panel is opened, the LCD panel will close after six seconds.
 - When the ignition switch is turned ON again (or turned to ACC), the LCD panel will open automatically.
 - Removing or attaching the front panel will automatically close or open the LCD panel. (Refer to *Protecting your unit from theft*)
- When the ignition switch is turned OFF after the LCD panel has been closed, turning the ignition switch ON again (or turning it to ACC) will not open the LCD panel. In this case, press **OPEN/CLOSE** to open the LCD panel.
- When closing the LCD panel, check to make sure that it has closed completely. If the LCD panel has stopped halfway, leaving it like this could result in damage.



CAUTION

Keep hands and fingers clear of the unit when opening, closing, or adjusting the LCD panel. Be especially cautious of children's hands and fingers.

- **Press OPEN/CLOSE to open the LCD panel.**
 - To close the LCD panel, press **OPEN/CLOSE** again.

Setting the automatic open function

To prevent the display from hitting the shift lever of an automatic vehicle when it is in the **P** (park) position, or when you do not wish the display to open/close automatically, you can set the automatic open function to manual mode.

- 1 **Press the home button to switch to the home display.**
- 2 **Touch the system key to open the system menu.**
- 3 **Touch Auto Flap to select whether to open/close the display automatically or manually.**

Each time you touch **Auto Flap** the setting switches between:

- **On** – The LCD panel will open or close automatically when the ignition switch is turned on or off.
- **Off** – You have to press **OPEN/CLOSE** to open/close the LCD panel.

Turning the LCD panel horizontally

When the LCD panel is upright and hinders the operation of the air conditioner, the panel can be turned horizontally temporarily.

- 1 **Press and hold OPEN/CLOSE to display the flap menu.**
- 2 **Touch the flip down temporarily key to flip the LCD panel down to the horizontal position.**



Flips the LCD panel down to the horizontal position temporarily.

Basic operations

- To return to the original position, press and hold **OPEN/CLOSE**.
- The LCD panel returns to the original position automatically, indicated with a beeping sound 10 seconds after operation.

Adjusting the LCD panel slide position

You can adjust the LCD panel slide position so that the panel is set back or forward.

- 1 Press and hold **OPEN/CLOSE** to display the flap menu.

- 2 Touch the slide back key or slide front key to move the LCD panel back and forth.



The LCD panel slides to the back.



The LCD panel slides to the front.

Adjusting the LCD panel angle

Important

- If you can hear the LCD panel knocking against your vehicle's console or dashboard, touch the flip down temporarily key from the flap menu to temporarily level the LCD panel.

- When adjusting the LCD panel angle, be sure to adjust from the flap menu. Forcibly adjusting the LCD panel by hand may damage it.



- 1 Press and hold **OPEN/CLOSE** to display the flap menu.

- 2 Touch the tilt down key or tilt up key to adjust the LCD panel to an easily viewable angle.

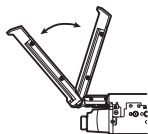

Laying the panel down.



Returning the panel to the upright position.

- As the set angle is saved, the LCD panel will automatically be adjusted to the same position the next time the LCD panel is opened.

Basic operations

Ejecting a disc

- Press **▲** to eject a disc.

Setting the clock

- 1 Touch the **Clock key**.
The **Clock Adjustment** screen appears.
For details refer to **Home display**

- 2 Select the item to set.

- 3 Touch **▲** or **▼** to set the correct date and time.

Tuner operations

Touch panel keys

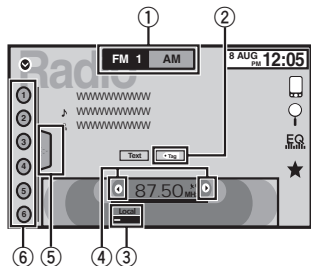

- Band key**
Selecting a band (**FM1**, **FM2** or **FM3**) by touching the left icon. Switching to the **AM** band by touching the right icon. The icon for the selected band is highlighted.
- Tag key**
Saving song information (tag) from the broadcasting station to your iPod.
- Local key**
Setting the local seek level.
- Tuning key**
Tuning up or down manually.
Touch and hold down for more than two seconds to skip stations. Seek tuning starts as soon as you release. Touch again to cancel seek tuning.
- List key**
Displaying the preset channel list.
- Preset channel key**
Selecting a preset channel.

Basic operations

Switching preset channels using the buttons

1 Press ◀ or ▶ (**TRK**).

Seek tuning using the buttons

1 Press and hold ◀ or ▶ (**TRK**).

Notes

- Listening AM radio while an iPod is charged from this unit may generate noise. In this case, disconnect the iPod from this unit.
- Touch panel keys not listed under *Tuner operations* may appear on the display. Refer to *Indicator list*.

Storing and recalling stations

You can easily store up to six stations for each band as presets.

1 Display the preset screen.

Refer to *Tuner operations*

The preset screen appears in the display.

2 Touch and hold down one of the preset channel keys to store the selected frequency to the memory.

The selected radio station frequency has been stored in the memory.

3 Touch the appropriate preset channel key to select the desired station.

Storing the strongest stations

BSM (best stations memory) automatically stores the six strongest stations in the order of their signal strength.

Storing broadcast frequencies with BSM may replace broadcast frequencies you have saved using the preset channel keys.

1 Display the preset screen.

Refer to *Tuner operations*

The preset screen appears in the display.

2 Touch BSM to turn BSM on.

The six strongest broadcast frequencies will be stored under preset channel keys in order of their signal strength.

- To cancel the storage process, touch **Cancel**.

Tuning in to strong signals

Local seek tuning allows you to tune in to only those radio stations with sufficiently strong signals for good reception.

FM: Off — — — — — — — — — —

— — — — —

AM: Off — — — — —

The more ■ there are on the screen, the fewer the stations that can be selected. Only stations with the strongest signals in your local area can be selected.

If there are fewer ■, this unit will be able to receive broadcasts from weaker stations.

Using iTunes tagging

Note

For more details about iTunes tagging, refer to *About iTunes tagging*

Storing the tag information to this unit

1 Tune in to the broadcast station.

2 Store the tag information to this unit.

Refer to *Tuner operations*

You can store the information if the **Tag** indicator is displayed while the desired song is being broadcast.

- While storing the tag data on this unit, **Tag** flashes.

- The tag information for up to 50 songs can be stored on this unit.

- Depending on the timing of when the tag information is stored, the tag information for the song played before or after the currently playing song may also be stored.

3 When completed, ◀ [Tag] indicator turns off and J indicator is displayed.

Storing the tagged information to your iPod

1 Connect your iPod.

When your iPod is connected to this unit, your iPod starts storing the tagged information automatically.

2 When completed, © indicator turns off and the tagged information is stored on your iPod.

Disc (CD/DVD)

Introducing movie operations

You can use this unit to view DVD/DVD-R/DVD-RW/CD/CD-R/CD-RW movie files.

Touch panel keys

DVD video

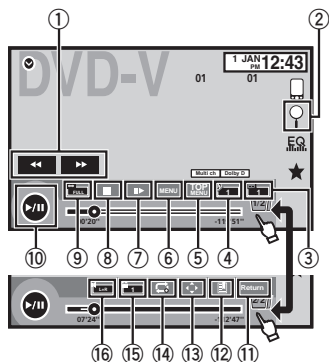

Video CD

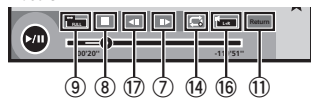

When playing a disc containing a mixture of various media file types

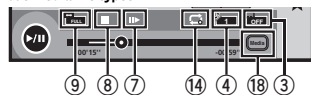

- ① **Fast forward key/Reverse key**
Fast forwarding or reversing

Touch to change the fast forward and reverse speed.

- ② **Search key**
Starting the search function.
- ③ **Switch subtitle language key**
With DVDs/DivX files featuring multi-subtitle recordings, you can switch between subtitle languages during playback.
- ④ **Switch audio language key**
With DVDs/DivX files that provides audio playback in different languages and different audio systems (Dolby® Digital, DTS, etc.), you can switch between languages/audio systems during playback. Depending on the setting, the video may not be played back with the audio system used to record the DVD.
- ⑤ **TOP MENU key**
Returning to the top menu during DVD playback.
- ⑥ **MENU key**
Displaying the DVD menu during DVD playback.
- ⑦ **Slow-motion playback key**
Moving the selection ahead one frame at a time during playback. Touch and hold down the key for more than two seconds to slow down playback speed. Touching the key increases the playback speed over four incremental settings during slow motion playback from DVD video/Video CD.
- ⑧ **Stop key**
Stopping playback. If you resume playback, playback will start from the point where you stopped. Touch the key again to stop playback completely.

Disc (CD/DVD)

- ⑨ **Screen mode key**
Changing the screen mode. Refer to *Changing the wide-screen mode*
- ⑩ **Pause and play key**
Pausing playback. Returning to normal playback during paused, slow motion, or frame-by-frame playback.
- ⑪ **Return key**
Returning to the specified scene to which the DVD currently being played has been pre-programmed to return. This function cannot be used if a specified scene has not been preprogrammed on the DVD disc.
- ⑫ **Bookmark key**
During playback, touch the point at which you want to resume playback the next time the disc is loaded.
 - You can set one bookmark per DVD video. You can set up to five bookmarks total.
 - To clear the bookmark on a disc, touch and hold the key during playback.
 - The oldest bookmark is replaced by the new one.
- ⑬ **Arrow key**
Displaying arrow keys to operate the DVD menu.
- ⑭ **Repeat key**
Selecting the repeat range.
- ⑮ **Viewing angle key**
With DVDs featuring multi-angle (scenes shot from multiple angles) recordings, you can switch among viewing angles during playback.
- ⑯ **Audio output key**
Switching the audio output, when playing video discs recorded with LPCM audio.
- ⑰ **Slow key**
Speeding down the playback speed in four steps, during slow motion playback on DVD video/Video CD.
 - There is no sound during slow motion playback.
 - Images during slow motion playback may be unclear for some discs.
 - Reverse slow motion playback is not available.
- ⑱ **Media key**
Switching between media file types to play on DVD/CD.

Basic operations

Playing back videos

- ① Insert the disc into the disc loading slot with the label side up. Playback will automatically start.
- If you are playing a DVD or Video CD, a menu may appear. Refer to *Operating the DVD menu and PBC playback*
 - When the automatic playback function is on, the unit will skip the DVD menu and automatically start playback from the first chapter of the first title. Refer to *Automatic playback of DVDs*
 - When the source icon is not displayed, it can be displayed by touching the screen.
 - If a message is displayed after loading a disc containing DivX VOD content, touch **PLAY**. Refer to *Playing DivX® VOD content on page*

Ejecting a disc

- Refer to *Ejecting a disc*

Disc (CD/DVD)

Selecting a chapter using the buttons

- 1 Press ◀ or ▶ (TRK).

Fast forwarding or reversing using the buttons

- 1 Press and hold ◀ or ▶ (TRK).
- Fast forward/fast reverse may not always be possible on some discs. In such cases, normal playback will automatically resume.
 - The fast forward/fast reverse speed depends on the length of time you press and hold down ◀ or ▶ (TRK). This function is not available for Video CD.

Notes

- This DVD player can play back a DivX file recorded on CD-R/RW, DVD-R/RW, or MPEG-1/MPEG-2/MPEG-4. (Please see the following section for files that can be played back. Refer to *DivX video files*.)
- Do not insert anything other than a DVD-R/RW or CD-R/RW into the disc loading slot.
- Some operations may not be available while watching a media due to the programming of the disc. In such cases, the  icon appears on the screen.
- There may be touch panel keys not listed under *Introducing movie operations* on page 13 that appear on the screen. Refer to *Indicator list*.
- With some DVDs, switching between languages/audio systems may only be possible using a menu display.
- You can also switch between languages/audio systems using **Video Setup** menu. For details, refer to *Setting the audio language*.
- This unit will return to normal playback if you change the audio language during fast forward/fast reverse, pause or slow motion playback.
- With some DVDs, switching between subtitle languages may only be possible using a menu display.

- You can also switch between subtitle languages using **Video Setup** menu. For details, refer to *Setting the subtitle language*.
- This unit will return to normal playback if you change the subtitle language during fast forward/fast reverse, pause or slow motion playback.
- During playback of a scene shot from multiple angles, the angle icon is displayed. Use the **Video Setup** menu to turn the angle icon display on or off. For details, refer to *Setting the multi-angle DVD display*.
- You will return to normal playback if you change the viewing angle during fast forward/fast reverse, pause or slow motion playback.

Sound playback operations

You can use this unit to listen to DVD-R/DVD-RW/CD/CD-R/CD-RW sound files.

Touch panel keys

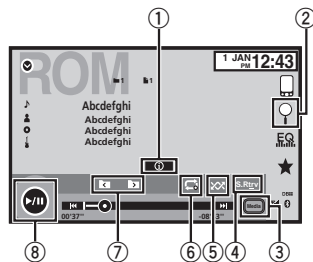

- 1 **Information key**
Switching the text information to display on this unit when playing MP3/WMA/AAC files.

Disc (CD/DVD)

- 2 **Search key**
Displaying a list of track titles/file names to select songs on a CD.
Displaying the file name list to select the files.
- 3 **Media key**
Switching between media file types on a DVD or CD.
- 4 **Sound retriever key**
Refer to *Using sound retriever*
- 5 **Random key**
Playing songs in random order.
- 6 **Repeat key**
Selecting the repeat range.
- 7 **Previous folder key/Next folder key**
Selecting a folder.
- 8 **Pause and play key**
Pausing and starting playback.

Switching the media file type

When playing a digital media containing a mixture of various media file types, such as DivX, MPEG-1, MPEG-2, MPEG-4 and MP3, you can switch between media file types to play.

- Touch Media to switch media file types.** CD (audio data (CD-DA))—Music/ROM (compressed audio)—Video (DivX, MPEG-1, MPEG-2, MPEG-4 video files)

Note

Audio data (CD-DA) files on DVD-R/RW/ROM cannot be played back on this unit.







Operating the DVD menu

(Function for DVD video)
Some DVDs allow you to make a selection from the disc contents using a menu.

Using the arrow keys

1 **Display arrow keys to operate the DVD menu.**

2 **Select the desired menu item.**

	Returning to the normal DVD video display.
	Displaying arrow keys.
	Selecting the desired menu item.
	
	
	
Enter	Starting playback from the selected menu item.
Touch	Operating the DVD menu by directly touching the menu item.
	Back to previous display.

- When operating the DVD menu by directly touching the menu item, touch the icon to operate.

Disc (CD/DVD)

- Ways to display the menu will differ depending on the disc.
- Depending on the contents of the DVD disc, this function may not work properly. In such cases, use the touch panel keys to operate the DVD menu.

Random play (shuffle)

- **Touch the random key.**
 - **On** – Play back files in random order within the repeat range. **Folder** and **Disc**.
 - **Off** – Cancel random play.

Repeating playback

- **Touch the repeat key.**
 - **Disc** – Play through the current disc
 - **Chapter** – Repeat the current chapter
 - **Title** – Repeat the current title
 - **Track** – Repeat the current track
 - **File** – Repeat the current file
 - **Folder** – Repeat the current folder
 - **One** – Repeat just the current video/song

Notes

- This function cannot be operated during Video CD playback featuring PBC (playback control).
- If you perform chapter search, fast forward/reverse, frame-by-frame playback or slow-motion playback, the repeat play will stop.
- When playing discs with compressed audio and audio data (CD-DA), playback is repeated within the type of data currently playing even if **Disc** is selected.
- If you select another folder during repeat play, the repeat play range changes to **Disc**.
- If you perform track search or fast forward/reverse during **File**, the repeat play range changes to **Folder**.
- If you perform title/chapter search or fast forward/reverse during **Chapter**, the repeat play is set to off automatically.

- If you perform track search or fast forward/reverse during **Track**, the repeat play range changes to **Disc**.
- When **Folder** is selected, it is not possible to play back a subfolder of that folder.

Searching for the part you want to play

You can use the search function to find the part you want to play.

For DVD videos, you can select **Title** (title), **Chapter** (chapter) or **10key** (numeric keypad). For video CDs, you can select **Track** (track) or **10key** (numeric keypad).

- Chapter search is not available when disc playback is stopped.
- This function cannot be operated during Video CD playback featuring PBC (playback control).

1 Start the search function.

Refer to *Introducing movie operations* on page 13.

2 Touch the desired search option (e.g., Chapter).

3 Touch 0 to 9 to input the desired number.

- To cancel the entered numbers, touch **C**.

4 Start playback from the selected part.



Registering the numbers and starting playback.

Note

With discs featuring a menu, you can also use the DVD menu to make your selection. Refer to *Introducing movie operations* on page 13.

Disc (CD/DVD)

Selecting audio output

When playing DVD video discs recorded with LPCM audio, you can switch the audio output. When playing video CDs, you can switch between stereo and monaural audio output.

- This function is not available when disc playback is stopped.

● Touch the audio output key to switch audio output types.

- **L+R** – Left and right
- **Left** – Left
- **Right** – Right
- **Mix** – Mixing left and right

Note

You may not be able to select or use this function depending on the disc and the playback location.

PBC playback

(Function for Video CDs)

During playback of Video CDs featuring PBC (playback control), **PBC On** is displayed.

1 Start the search function.

Refer to *Introducing movie operations* on page 13.

2 Touch 10key to display the numeric keypad.

3 Touch 0 to 9 corresponding to a menu number.

4 Start playback from the selected part.



Registering the numbers and starting playback.

Notes

- You can display the menu by touching **Return** during PBC playback. For details, refer to the instructions provided with the disc.
- PBC playback of a Video CD cannot be canceled.
- During playback of Video CDs featuring PBC (playback control), you cannot select the repeat play range or use the search function.

Selecting tracks from the track title list

You can select tracks to playback using the track title list which is a list of the tracks recorded on a disc.

1 Display the track title list.

Refer to *Sound playback operations* on page 14.

2 Touch your favorite track title.

Playback begins.

Selecting files from the file name list

(Function for compressed audio/DivX/MPEG-1/MPEG-2/MPEG-4)

File name list is a list of file names (or folder names) from which you can select a file (or folder) to play back.

1 Touch the search key to display the file (or folder) name list.

2 Touch your favorite file (or folder) name.

- When you have selected a folder, a list of the names of the files (or the folders) in it can be viewed. Repeat this operation to select the desired file name.
- If folder **1** (ROOT) contains no files, playback starts from folder **2**.

Disc (CD/DVD)

Note

If part of the recorded information does not display, a scroll key appears on the right side of list. Touch the scroll key to scroll.

Playing DivX® VOD content

Some DivX video on demand (VOD) content may only be playable a fixed number of times. When you load a disc containing this type of content, the number of times it has been played will be shown on-screen. You can then decide whether or not to play the disc.

- For DivX VOD content without this restriction, you can load the disc into your player and play the content as often as you like, with no message displayed.
- You can confirm the number of times that the content can be played by checking the message, **This DivX rental has used** **out of** **views..**

Important

- In order to play DivX VOD contents on this unit, you first need to register the unit with your DivX VOD contents provider. For details on your registration code, refer to *Displaying the DivX® VOD registration code*
- DivX VOD content is protected by a DRM (Digital Rights Management) system. This restricts playback of content to specific, registered devices.

- **If a message is displayed after loading a disc containing DivX VOD content, touch PLAY.**

Playback of the DivX VOD content will start.

- To skip to the next file, touch **NEXT**.
- If you do not want to play the DivX VOD content, touch **STOP**.

iPod

iPod control

This manual applies to the following iPod models.

iPod with 30-pin connector

- iPod touch 4th generation
- iPod touch 3rd generation
- iPod touch 2nd generation
- iPod touch 1st generation
- iPod classic 160GB
- iPod classic 120GB
- iPod classic
- iPod with video
- iPod nano 6th generation
- iPod nano 5th generation
- iPod nano 4th generation
- iPod nano 3rd generation
- iPod nano 2nd generation
- iPod nano 1st generation
- iPhone 4S
- iPhone 4
- iPhone 3GS
- iPhone 3G
- iPhone

iPod with lightning connector

- iPod touch 5th generation
- iPod nano 7th generation
- iPhone 5

For iPod with lightning connector users

- Use the Lightning to USB Cable (Supplied with iPod/iPhone) when you use this function.
- Refer to *When connecting with Lightning to USB Cable*
- Functions related to iPod movie files are not available.
- If **AppRadio Mode** is used, the functions in this section cannot be used.
Refer to *AppRadio Mode operation*

Moving images operations**For iPod with 30-pin connector users**

You can use the unit to view iPod movie files.

- Depending on your iPod, there may not be any output unless you use CD-IU201S/CD-IU201V (sold separately). Be sure to use CD-IU201S/CD-IU201V to connect your iPod.

For iPod with lightning connector users

- This function is not available.

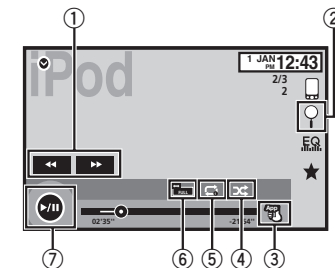
Touch panel keys

- 1 Fast forward key/Reverse key**
Fast forwarding or reversing
Touch to change the fast forward and reverse speed.
- 2 Search key**
Displaying iPod menus.
- 3 iPod control mode key**
Conducting operation from your iPod and listening to it using your car's speakers.
- 4 Shuffle key**
Playing the video on your iPod in a random order.

iPod

- ⑤ **Repeat key**
Selecting the repeat range.
- ⑥ **Screen mode key**
Changing the screen mode.
Refer to *Changing the wide-screen mode*
- ⑦ **Pause and play key**
Pausing playback.
Returning to normal playback during paused, slow motion, or frame-by-frame playback.

Basic operations

Playing back videos

- ① Touch the search key to pull up the iPod menus.
- ② Select a movie to play.
Refer to *Playing videos from your iPod* on page 18.
 - When the source icon is not displayed, it can be displayed by touching the screen.
 - Disconnect headphones from the iPod before connecting it to this unit.
 - Depending on the iPod model and the amount of data stored in the iPod, it may take some time for playback to begin.
 - Use the touch panel keys to select the iPod after connecting it to this unit.
 - **No Device** is displayed when disconnecting the iPod.

Fast forwarding or reversing using the buttons

- ① Press and hold ◀ or ▶ (TRK).

Notes

- To ensure proper operation, connect the dock connector cable from the iPod directly to this unit.
- While the iPod is connected to this unit, the iPod cannot be turned on or off.

- Touch panel keys not listed under *Moving images operations* may appear on the display. Refer to *Indicator list*

Sound playback operations

You can use the unit to listen iPod sound files.

Note

The play time may not display correctly.

Touch panel keys

iPod audio (Control Audio)

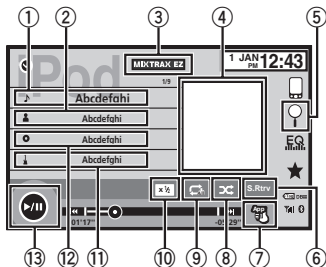

iPod audio (App Mode)

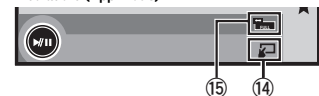

- ① **Song title**
Displaying the **Songs** list on the iPod.
- ② **Artist name**
Displaying the **Artists** list on the iPod.
- ③ **MIXTRAX EZ key**
Starting MIXTRAX EZ.
Refer to *MIXTRAX EZ operation*
- ④ **Artwork**
Starting link search on your iPod when you touch the artwork display.
- ⑤ **Search key**
Displaying iPod menus.
- ⑥ **Sound retriever key**
Refer to *Using sound retriever*
- ⑦ **iPod control mode key**
Conducting operation from your iPod and listening to it using your car's speakers.
- ⑧ **Shuffle key**
Playing songs on the iPod in random order.
- ⑨ **Repeat key**
Selecting the repeat range.
- ⑩ **Change speed key**
Changing the speed of audiobook playback on the iPod.
- ⑪ **Genre**
Displaying the **Genres** list on the iPod.
- ⑫ **Album title**
Displaying the **Albums** list on the iPod.
- ⑬ **Pause and play key**
Pausing and starting playback.
- ⑭ **Unit operation key**
Performing operations from this unit and listening to the music on your iPod using your car's speakers.
- ⑮ **Screen mode key**
Changing the screen mode.

iPod

Using this unit's iPod function from your iPod

You can listen to sound from applications on your iPod using the car's speakers when **App Mode** is selected.

This function is not compatible with the following iPod models.

- iPod nano 1st generation
- iPod with video

Notes

- Video-related functions are not available to iPod with lightning connector users.
- While this function is in use, the iPod will not turn off even if the ignition key is turned off. Operate the iPod to turn off the power.

1 Switch the control mode to App Mode.

Refer to *Moving images operations*

Refer to *Sound playback operations*

2 Operate the connected iPod to select a video/song and play.

Notes

- The following functions are still accessible from the unit even if the control mode is set to **App Mode**. However, the operation will depend on your applications.
 - Playing/pausing
 - Fast forwarding/reversing
 - Tracking up/down
 - Moving to a chapter up/down
- **App Mode** is compatible with the following iPod models.
 - iPod touch 4th generation
 - iPod touch 3rd generation
 - iPod touch 2nd generation
 - iPod touch 1st generation
 - iPod classic 160GB
 - iPod classic 120GB
 - iPod classic

- iPod nano 6th generation
- iPod nano 5th generation
- iPod nano 4th generation
- iPod nano 3rd generation
- iPod nano 2nd generation
- iPhone 4S
- iPhone 4
- iPhone 3GS
- iPhone 3G
- iPhone

Shuffle play

- **Touch the shuffle key.**
 - **Songs** – Play back videos/songs in the selected list in random order.
 - **Albums** – Play back videos/songs from a randomly selected album in order.
 - **Off** – Turn off shuffle play.

Repeating playback

- **Touch the repeat key.**
 - **One** – Repeat just the current video/song
 - **All** – Repeat all videos/songs in the selected list on the iPod

Playing videos from your iPod

- Videos can be played on this unit if an iPod with video capabilities is connected.
- This unit can play back "Movies", "Music videos", "Video Podcast" and "TV show" which are downloaded from the iTunes store.

Note

This function is not available to iPod with lightning connector users.

1 Touch Search to display iPod menus.

Refer to *Moving Images operations* on page 16.

2 Switch to iPod video mode.

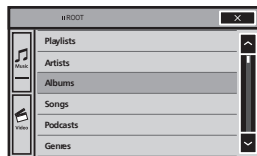

- If you want to switch to iPod video mode, touch the icon.



Switching to iPod video mode.

3 Play the video from the iPod.

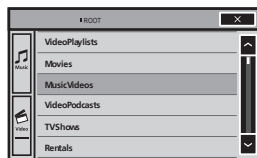

- If you want to switch to iPod music mode, touch the icon.



Switching to iPod music mode.

Browsing for a video/music on the iPod

To make operating and searching easy, operations to control an iPod with this unit are designed to be as similar to the iPod as possible.

Note

Video-related functions are not available to iPod with lightning connector users.

Searching for a video/music by category

1 Touch the search key to pull up the iPod menu.

Refer to *Sound playback operations*

2 Touch one of the categories in which you want to search for a video/music.

- **Video Playlists** (video playlists)
- **Movies** (movies)
- **Music Videos** (music videos)
- **Video Podcasts** (video podcasts)
- **TV Shows** (TV shows)
- **Playlists** (playlists)
- **Artists** (artists)
- **Albums** (albums)
- **Songs** (songs)
- **Podcasts** (podcasts)
- **Genres** (genres)
- **Composers** (composers)
- **Audiobooks** (audiobooks)

3 Touch the title of the list that you want to play.

Repeat this operation until you find the desired video/music.

Notes

- Depending on the generation or version of the iPod, some functions may not be available.
- You can play playlists created with the MusicSphere application. The application will be available on our website.
- Playlists that you created with the MusicSphere application are displayed in abbreviated form.

Searching the list by alphabet

1 Select a category.

Refer to *Searching for a video/music by category*

2 Switch to alphabet search mode.

ABC

Switching to alphabet search mode.

Alphabet search mode is displayed.

3 Touch the first letter of the title of the video/song you are looking for.

While searching, touch panel key operation is not available.

- To refine the search with a different letter, touch **Cancel**.

4 Touch the title of the list that you want to play.

Repeat this operation until you find the desired song/video.

Changing audiobook speed

- **Touch the change speed key to change the speed.**

× 2

Playback at a speed faster than normal

× 1

Playback at normal speed

× 1/2

Playback at a speed slower than normal

iPod

Displaying lists related to the song currently playing (link search)

Touch the artwork to open a list of the names of songs on the album currently playing. Touch the name of the song you want to play to start playing that song.

Note

If part of the recorded information does not display, a scroll key appears on the right side of list. Touch the scroll key to scroll.

AppRadio Mode

AppRadio Mode operation

This system can switch to the **AppRadio Mode**, which you can display and operate the application for iPhone on the screen.

In **AppRadio Mode**, you can operate applications with finger gestures such as tapping, dragging, scrolling or flicking on the screen of the system.

Install the AppRadio app on your iPhone.



WARNING

Certain uses of a smartphone may not be legal while driving in your jurisdiction, so you must be aware of and obey any such restrictions.

If in doubt as to a particular function, only perform it while the car is parked.

No feature should be used unless it is safe to do so under the driving conditions you are experiencing.



CAUTION

While driving, you cannot enter text on your iPod.

- Pioneer is not liable for any issues that may arise from incorrect or flawed app-based content.
- The content and functionality of the supported applications are the responsibility of the App providers.
- In **AppRadio Mode**, functionality through the product is limited while driving, with available functions determined by the App providers.
- Availability of **AppRadio Mode** functionality is determined by the App provider, and not determined by Pioneer.
- **AppRadio Mode** allows access to applications other than those listed (subject to limitations while driving), but the extent to which content can be used is determined by the App providers.



Important

- The only port that supports **AppRadio Mode** is USB input.
- When listening to music and sounds from application simultaneously, see the following section. Refer to *Setting the App sound mixing*

Notes

- Applications operable by switching this system to **AppRadio Mode** are only those available for **AppRadio Mode**.
- Please check applications supported **AppRadio Mode**

iPhone compatibility

AppRadio Mode is compatible with the following iPod models.

AppRadio Mode

- iPod touch 5th generation
- iPod touch 4th generation
- iPhone 5
- iPhone 4S
- iPhone 4

Starting procedure

1 Install the AppRadio app on your iPhone.

2 After configuring RGB Input, connect the iPhone to this unit.

- **For iPod with lightning connector users** (Function of AVH-X7500BT)
 - Set **RGB Input to iPhone (VGA adapter)**.
 - Use the CD-IV202AV (sold separately) and Lightning to VGA adapter (Apple Inc. products) (sold separately) when you use this function.
 - Refer to *When connecting with optional CD-IV202AV cable*.
 - A Bluetooth connection is required for iPod with lightning connector. Refer to *Bluetooth connection menu*.
- **For iPod with 30-pin connector users**
 - Set **RGB Input to iPhone (CD-IU201S)**.
 - Use the CD-IU201S (sold separately) when you use this function.
 - Refer to *When connecting with optional CD-IU201S cable*.

3 Start an application available for AppRadio Mode from the iPhone.

An image of the application is displayed on the screen of this system.

- You can start an application available for **AppRadio Mode** also from a launcher application.

4 Press MODE.

- Press the home button to switch to the home display and then touch the **Apps** key to start the launcher application.

5 Operate the application.

Setting the Keyboard

CAUTION

For your safety, the keyboard functionality is only available when the vehicle is stopped and the parking brake is engaged.

Depending on the application, you can input text on the display. In order to input text correctly using keyboard which appears on this unit, you need to set the language setting in this function. When the **AppRadio Mode** is used, the language setting for the keyboard set for the function and the language setting for the iPhone keyboard need to be the same.

- Keyboard is available only in **AppRadio Mode**.

When you tap a text input area of an application for iPhone, a keyboard will be displayed on-screen. You can input the desired text directly from this system.

- The language preference for the keyboard of this system should be same as the setting on your iPhone.
If the settings for this product and the iPhone are different, you may not be able to enter characters properly.

1 Press the home button twice to switch from the AppRadio Mode display to the home display.

2 Touch the system key to open the system menu.

3 Touch Keyboard on the System menu to select desired language.

AppRadio Mode

4 Touch < or > to select a desired language.

French (French)—**German** (German)—**Greek** (Greek)—**Russian** (Russian)—**English** (US English)—**English (UK)** (UK English)—**Dutch** (Dutch)—**Italian** (Italian)—**Norwegian** (Norwegian)—**Swedish** (Swedish)—**Finnish** (Finnish)—**Spanish** (Spanish)—**Portuguese** (Portuguese)

5 Tap the text input area on the application screen of the iPhone.

Touch  to hide the keyboard.

Setting the App sound mixing

You cannot turn on or off Mixing when this unit is playing a song of iPod.
The sound of application during **AppRadio Mode** can be adjusted.
Enable this setting when you want to mix the App sound with the sound from a built-in source (such as the radio). The volume of the App sound can be selected from three levels.

This function is not available when **RGB Input** is set to **iPhone (VGA adapter)**.
Refer to *Setting the RGB Input*

1 Press the home button twice to switch from the AppRadio Mode display to the home display.

2 Touch the system key to open the system menu.

3 Touch App sound mixing on the System menu to select desired setting. OFF (off)—Low (low)—Mid (mid)—High (high)

USB

Sound playback operations

You can use this unit to listen to USB audio files.

Notes

- The play time may not display correctly.
- When playing back files recorded as VBR (variable bit rate) files, the play time will not be correctly displayed if fast forward or reverse operations are used.
- To ensure proper operation, connect the dock connector cable from the iPod directly to this unit.
- While the iPod is connected to this unit, the iPod cannot be turned on or off.
- If the characters recorded on the disc are not compatible with this unit, those characters will not be displayed.
- Text information may not be correctly displayed depending on the recorded environment.
- Disconnect the USB portable audio player/USB memory when you are done using it.
- When you select **Speana** on *Selecting the background display*

Touch panel keys

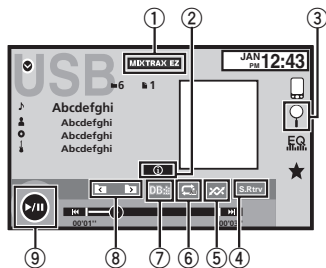

- 1 **MIXTRAX EZ key**
Starting MIXTRAX EZ.
- 2 **Information key**
Switching the text information to display on this unit when playing MP3/WMA/AAC/WAV files.
- 3 **Search key**
Displaying the file name list to select the files.
- 4 **Sound retriever key**
Refer to *Using sound retriever*
- 5 **Random key**
Playing songs in random order.
- 6 **Repeat key**
Selecting the repeat range.
- 7 **DB key**
Creating a database that enables searches by artist name, genre, and other options. Refer to *Music browse mode*
- 8 **Previous folder key/Next folder key**
Selecting a folder.
- 9 **Pause and play key**
Pausing and starting playback.

Basic operations

Playing back tracks
Connect the USB device. Playback will automatically start. When the source icon is not displayed, it can be displayed by touching the screen.
Fast forwarding or reversing using the buttons
Press and hold or (TRK).

USB

Music browse mode

(Function for USB)

This unit creates an index in order to facilitate browsing for a song. You can search by the categories such as albums and artists.

CAUTION

- This function is not available when the USB storage device is locked.
- This function is not available when the free space of USB storage device is less than 5 MB.
- While this unit creates an index, do not turn the unit off. It may cause loss of data on your USB storage device.

1 Touch DB to create a database in Music browse mode.

Refer to *Sound playback operations*

2 When "Save the Database to memory?" is displayed, touch "Yes".

Saving of the database is completed. If you do not save it, touch "No".
When the saving is completed, "Completed saving Database to memory." appears.
Music browse mode will start.

3 Display a list and touch the tag key.

4 Select a file.

Random play (shuffle)

- **Touch the random key.**
 - **On** – Play back files in random order within the repeat range.
 - **Off** – Cancel random play.

Repeating playback

- **Touch the repeat key.**
 - **File** – Repeat the current file
 - **Folder** – Repeat the current folder
 - **All** – Repeat all files
 - When **Folder** is selected, it is not possible to play back a subfolder of that folder.
 - If you select USB source, the repeat play range changes to **All**.

Selecting files from the file name list

(Function for compressed audio)
Operation is the same as that for Disc.
Refer to *Selecting files from the file name list*

Displaying lists related to the song currently playing (link search)

Touch the artwork to open a list of the names of songs on the album currently playing. Touch the name of the song you want to play to start playing that song.

Notes

- If part of the recorded information does not display, a scroll key appears on the right side of list. Touch the scroll key to scroll.
- This function is available for USB devices in Music browse mode.

Sound playback operations

(Function of AVH-X7500BT)

You can use this unit to listen to Bluetooth audio files.

Notes

- Depending on the Bluetooth audio player connected to this unit, the available operations will be limited to the following two levels:
 - A2DP profile (Advanced Audio Distribution Profile): You can only playback songs on your audio player.
 - AVRCP profile (Audio/Video Remote Control Profile): You can perform playback, pause playback, select songs, etc.
- As there is a wide variety of Bluetooth audio players available on the market, operations available with specific models may vary extensively. When attempting to run a Bluetooth audio player using this unit, refer to the instruction manual that came with the player as well as to this manual for assistance.
- As the signal from your cellular phone may cause noise, avoid using it when you are listening to songs on your Bluetooth audio player.
- The sound from a Bluetooth audio player connected to this unit will be muted while a call is in progress on a cellular phone connected to this unit via Bluetooth wireless technology.
- The play time may not display correctly.
- Depending on the type of Bluetooth audio player you have connected to this unit, operation and information display may not be available for some functions.

Touch panel keys

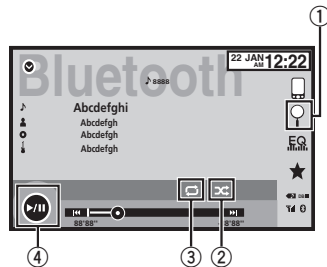

- Search key**
Displaying the file name list to select the files.
- Random key**
Playing songs in random order.
- Repeat key**
Selecting the repeat range.
- Pause and play key**
Pausing and starting playback.

Setting up for Bluetooth audio

Before you can use the Bluetooth audio function you must establish a Bluetooth wireless connection between the unit and your Bluetooth audio player.

- [1] Connection**
First, you need to connect a Bluetooth audio to this unit.
For detailed instructions on connecting your Bluetooth audio to this unit via Bluetooth wireless technology, refer to *Bluetooth connection menu*.

Notes

- When playing back files recorded as VBR (variable bit rate) files, the play time will not be correctly displayed if fast forward or reverse operations are used.
- To ensure proper operation, connect the dock connector cable from the iPod directly to this unit.
- While the iPod is connected to this unit, the iPod cannot be turned on or off.
- If the characters recorded on the disc are not compatible with this unit, those characters will not be displayed.
- Text information may not be correctly displayed depending on the recorded environment.

Random play (shuffle)

- Touch the random key.**
 - On** – Play back files in random order.
 - Off** – Cancel random play.

Repeating playback

- Touch the repeat key.**
 - One** – Repeat the current song only
 - All** – Repeat all songs

Using MIXTRAX

MIXTRAX operation

MIXTRAX is original technology for creating non-stop mixes of selections from your audio library, complete with DJ effects that make them sound as if a DJ is right there with you playing the music.

MIXTRAX EZ operation

You can use this unit to play iPod/USB audio files.

MIXTRAX EZ is used to add a variety of sound effects between songs for arranging the pauses between songs. It allows you to enjoy listening to music non-stop.

- This function is only available when a file on a USB storage device or a song on an iPod is being played.
- This function is not available when the control mode is set to **App Mode**.
- Depending on the file/song, sound effects may not be available.
- Depending on the file/song, non-stop playback may not be available.

Starting MIXTRAX EZ operation

- Touch MIXTRAX EZ.

Setting MIXTRAX mode

Turn on this function to play back audio files using MIXTRAX.

- 1 Press the home button to switch to the home display.
- 2 Touch the system key to open the system menu.

3 Touch MIXTRAX Setup on the system menu.

MIXTRAX setting items are displayed.

- **Short Playback Mode** – When turned on, select an audio track playback length.
60s (60 sec.)—**90s** (90 sec.)—**120s** (120 sec.)—**150s** (150 sec.)—**180s** (180 sec.)—**Random** (random)—**Off** (off)

When **Random** is selected, the playback time varies between 60 s, 90 s, 120 s, 150 s, and 180 s selected at random when the playback song changes.

- **Display Effect** – When **Display Effect** is set to **Disp&Key**, the artwork display and keys can be moved according to the music type.
Disp&Key (display and key)—**Key** (key)—**OFF** (off)
- **Cut-In Effect** – When **Cut-In Effect** is set to on, sound effects will play between tracks.
- **Effect Setting** – Use **Effect Setting** to set up the sound effect you want to insert between tracks.
- **Flash Pattern** – Use **Flash Pattern** to select the flash color pattern that can flash when the MIXTRAX is turned on.

Random 1—Sound 1—Sound 2—Sound 3—Sound 4—Sound 5—Sound 6—Random 2—L-Pass 1—L-Pass 2—L-Pass 3—L-Pass 4—L-Pass 5—L-Pass 6—Random 3

Setting the effect

You can change the settings for fixed sounds and sound effects.

There are six different fixed sounds available that can be inserted for playback between tracks.

The sound effects are used as effects to signal the end of a song being played and the beginning of the next song in series.

The fixed sounds and sound effects are set as combinations as MIXTRAX sounds.

Using MIXTRAX

Fixed sounds

- **Phaser** – A fixed sound that sounds like surging waves.
- **Roll** – A fixed sound that repeats playback of a certain sound.
- **Turntable1** – A fixed sound that mimics DJ scratching.
- **Flanger1** – A rushing sound that mimics that rising and falling sounds of a jet engine.
- **Reverb** – A fixed sound effect that creates a reverberation effect.
- **Echo** – A fixed sound effect that creates an echoing effect.

Sound effects

- **Cross Fade** – A sound effect that creates a fade in and fade out effect between songs.
- **Flanger** – A rushing sound that mimics that rising and falling sounds of a jet engine.
- **Echo** – A sound effect that creates an echoing effect.
- **Loop** – A sound effect that repeats playback of one section of a song track.

Setting sounds and sound effects as presets using the preset key

The **Standard** and **Simple** sound effects are set already as default presets.

- Touch **Standard** or **Simple** to check the settings.

The registered preset sound effect for the key that was touched is set as a preset.

Registering sounds and sound effects as presets

Registers a desired combination of sounds and sound effects to **Custom**.

Touch **Custom** to easily set the desired sound or sound effect.

- 1 Touch **Custom**.

2 Add a check mark to the desired sound effect by touching the option.

The marked sound effect is registered as a preset in **Custom**.

Notes

- If a sound effect is touched in the selection screen for **Standard** or **Simple**, the **Custom** screen is automatically displayed and the sound effect is registered to **Custom**.
- You can listen to fixed sounds to hear examples by touching the speaker icon.

Streaming Pandora®

Pandora operations

To play Pandora on the Pioneer car audio/video products, connect an iPod, iPhone or Android™ device with the most recent Pandora application installed, and start the Pandora application.

For iPod users

- Connect an iPod to USB input.
- Set **Pandora Connection to iPhone**. (Function of AVH-X7500BT) (This setting is not required for AVH-X6500DVD.)

For Android device users

- (Function of AVH-X7500BT)
- Set **Pandora Connection to Android**.
- A Bluetooth connection is required for Android devices. Refer to *Bluetooth connection menu*

Important

Requirements to access Pandora using the Pioneer car audio/video products: Connect an iPod to USB input or an Android device using Bluetooth to play Pandora on this unit.

- iPod and iPhone compatibility
Apple iPhone (first generation), iPhone 3G, iPhone 3GS, iPhone 4, iPhone 4S, iPhone 5, iPod touch 1G, iPod touch 2G, iPod touch 3G, iPod touch 4G or iPod touch 5G (firmware version 3.0 or later)
Certain firmware versions for the iPhone may not be compatible with the Pandora application. If this appears to be the case, please update the firmware to a version that is compatible with Pandora.
- Android compatibility
Android OS Version 2.2 or later
- Latest version of the Pandora application, downloaded to your device (Search Apple iTunes App Store or Google Play for "Pandora").

- Current Pandora account (if you do not have a Pandora account)
- Data Plan
Note: If the Data Plan for your iPhone or Android device does not provide for unlimited data usage, *additional charges from your carrier may apply* for accessing the Pandora service via 3G and/or EDGE networks.
- Connection to the Internet via 3G, EDGE or Wi-Fi network.
- Optional Pioneer adapter cable connecting your iPhone to the Pioneer car audio/video products.

Limitations:

- Access to the Pandora service will depend on the availability of a cellular and/or Wi-Fi network for purposes of allowing your device to connect to the Internet.
- Ability of the Pioneer car audio/video products to access the Pandora service is subject to change without notice and could be affected by any of the following: compatibility issues with future firmware versions of iPhones or Android devices; compatibility issues with future firmware versions of the Pandora application for them; changes to the Pandora music service by Pandora; discontinuation of the Pandora music service by Pandora.
- Certain functions of the Pandora service are not available when accessing the service through the Pioneer car audio/video products, including, but not limited to, creating new stations, deleting stations, emailing current stations, buying tracks from iTunes, viewing additional text information, logging in to Pandora, and adjusting Cell Network Audio Quality.

Pandora internet radio is a music service not affiliated with Pioneer.

Streaming Pandora®

Setting the Pandora connect mode

(Function of AVH-X7500BT)

Note

This function is not available when **RGB Input** is set to **iPhone (VGA adapter)**. Refer to *Setting the RGB Input* on page 33.

1 Press the home button to switch to the home display.

2 Touch the system key to open the system menu.

3 Touch Pandora Connection repeatedly until the desired setting appears on the screen.

iPhone: An iPod is connected using an actual cable.

Android: An Android device is connected using Bluetooth.

4 Touch the connect key.

(Only when **Pandora Connection** is set to **Android**)

Touch panel keys

Pandora (Control Audio)

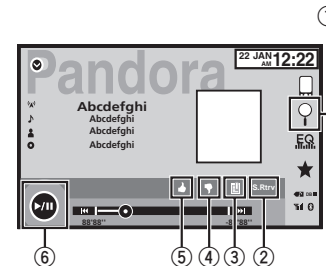

Pandora (Connect Mode)

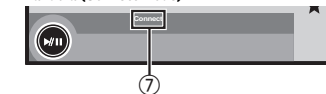

- 1 Search key**
Displays the shuffle/station list. Select the desired station or shuffle mode.
- 2 Sound retriever key**
(Only available on iPod)
Refer to *Using sound retriever*
- 3 Bookmark key**
Stores track information (Bookmark).
Bookmarks are viewable in your profile.
- 4 Thumbs-down key**
Giving a "thumbs-down" tells Pandora you do not like the current track. Pandora will skip to the next track, and will not play that track on the station again.

Streaming Pandora®

5 Thumbs-up key

Giving a "thumbs-up" tells Pandora that you like the current track. Pandora will continue to play that track and tracks like it on the station.

6 Pause and play key

Pausing and starting playback.

7 Connect key

(Function of AVH-X7500BT)
Starting the connection to Pandora.

Basic operations

Playing tracks

- For an iPod with lightning connector or an Android device, a Bluetooth connection is required as well.
Refer to *Pandora operations* on page 24.
- Switch the source to **Pandora**.

Skipping tracks

- Press **▶ (TRK)**.

Notes

- Touch panel keys not listed under *Pandora operations* may appear on the display. Refer to *Indicator list*.
- Pandora limits the number of skips allowed on their service. If you attempt to skip tracks beyond the limit, "**Skip limit reached.**" is displayed. If you have reached the skip limit and you give a "thumbs-down", the current track will continue to play, but your feedback will be registered.

Selecting and playing Pandora® stations/shuffle

Touch the list for your Pandora stations to select one of them to play.

1 Display the shuffle/station list.

Refer to *Pandora operations*.

2 Change the sort order.



You can sort the items in the list alphabetically.



You can sort the items in the list in order of the dates on which the items were created.



You can scroll the titles in the list while you touch and hold down the scroll icon.

3 Select shuffle or the desired station.



Shuffle mode will play tracks from your selected stations. You can edit shuffle preferences on your mobile device.

Note

Stations indicated by are shared stations.

Bluetooth telephone

Bluetooth telephone operations

(Function of AVH-X7500BT)

You can use Bluetooth telephone.

Important

- Leaving the unit on standby to connect to your phone via Bluetooth while the engine is not running can drain the battery.
- Advanced operations that require attention such as dialing numbers on the monitor, etc., are prohibited while driving. Park your vehicle in a safe place when using these advanced operations.
- Bluetooth connection menu cannot be selected while driving.
- Operations available may be limited depending on the cellular phone connected to this unit.
- Be sure to park your vehicle in a safe place and apply the parking brake when performing this operation.
- If you are unable to complete the connection using this unit, use the device to connect to the unit.
- If you connect more than one device at a time, connected device may not operate properly. Connecting one device at a time is recommended.

Touch panel keys

Telephone standby display

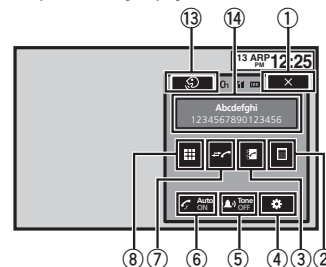

When switching to the entering phone number mode

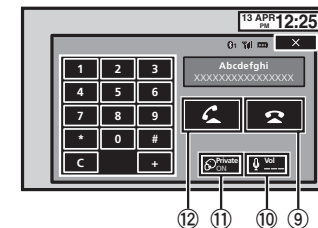

1 Close key

Display is closed.

2 Preset dial key

Displaying the preset dial screen.

3 Phone book key

Switching to the phone book mode.

4 Setting key

Displaying the Bluetooth connection menu.

Bluetooth telephone

5 Tone key

Turning the ring tone for incoming calls on or off.

6 Auto-answer key

Turning automatic answering on or off.

7 History key

Switching to the missed, received and dialed call lists.

8 Key pad key

Switching the mode to enter the phone number directly.

9 On-hook key

Ending a call.
Rejecting an incoming call.
Canceling call waiting.

10 Volume key

Adjusting the other party's listening volume.

11 Private mode key

Turning private mode on or off.

12 Off-hook key

Accepting an incoming call.
Making a phone call, when selecting a phone number.
Switching between callers on hold.

13 Voice control key

Notes

- Private mode can only be operated while you are talking on the phone.
- To end the call, both you and the other caller must hang up your phones.
- Touch panel keys not listed under *Bluetooth telephone operations* may appear on the display.
Refer to *Indicator list*.

Text information

14 Incoming call notice

Indicates that an incoming call has been received and has not been checked yet.

- Not displayed for calls made when your cellular phone is disconnected from this unit.

Setting up for hands-free phoning

Before you can use the hands-free phoning function you must set up the unit for use with your cellular phone. This entails establishing a Bluetooth wireless connection between this unit and your phone, registering your phone with this unit, and adjusting the volume level.

1 Connection

First, you need to connect a Bluetooth telephone to this unit.

For detailed instructions on connecting your phone to this unit via Bluetooth wireless technology, refer to *Pairing from this unit*.

2 Volume adjustment

Adjust the earpiece volume of your cellular phone to your preference. The unit will record the adjusted volume level as the default setting.

Notes

- The volume of the caller's voice and ring tone may vary depending on the type of cellular phone.
- If there is a large volume difference between the ring tone and caller's voice, the overall volume level may become unstable.

Bluetooth telephone

- Make sure to adjust the volume to a proper level before disconnecting the cellular phone from the unit. If the volume is muted (zero level) on your cellular phone, the volume level of your cellular phone remains muted even after the cellular phone is disconnected.

Calling a number in the phone book

The contacts on your phone will normally be transferred automatically when the phone is connected. If it is not, use your phone menu to transfer the contacts. The visibility of this unit should be on when you use the phone menu. Refer to *Switching visible unit*. After finding the number you want to call in the phone book, you can select the entry and make the call.

1 Touch the phone book key to switch to the phone book mode.

2 Select the phone number list.

The detailed phone number list of the selected entry is displayed.

3 Select the phone number.

- If you want to store the phone number, touch and hold the list.

4 Touch the off-hook key to make the call.

5 Touch the on-hook key to end the call.

1 Touch the phone book key to switch to the phone book mode.

2 Touch ABC to switch to alphabet search mode.

3 Touch the first letter of the entry you are looking for.

The Phone Book entries starting with that letter (e.g. "Ben", "Brian" and "Burt" when "B" is selected) will be displayed.

- If you want to change the character to Russian, touch the icon. To return to English, touch the icon again.



Changing the character to Russian.

- The order of the first name and last name may be different from that of the cellular phone.

4 Touch the list to display the phone number list of the selected entry.

- If several phone numbers are included in an entry, select one by touching the list.
- If you want to switch to the call history list, touch the icon.



Switching to the call history list.

5 Touch the off-hook key to make the call.

6 Touch the on-hook key to end the call.

Selecting a number by alphabet search mode

If a lot of numbers are registered in the phone book, you can search for the phone number by alphabet search mode.

Bluetooth telephone

Inverting names in phone book

When your cellular phone is connected to this unit, the first and last names of your contacts may be registered to the phone book in reverse order. You can use this function to change the order back.

(Inverting the names in the phone book)

1 Touch the phone book key to switch to the phone book mode.

2 Invert names in phone books.



Inverting names in phone books.

3 “Would you like to invert all names?” appears. Touch Yes to continue.

While the names are inverted, is displayed.

- If the inversion fails, “Invert Name Error” appears. In such cases, try again from the beginning.

Note

Inverting the names of your contacts from this unit does not affect the data on your Bluetooth device.

Using the missed, received and dialed call lists

The 80 most recent calls dialed, received, and missed are stored in the memory. You can browse them and call numbers from these lists.

1 Touch the history key to display the call history list.

2 Select Missed Calls, Dialed Calls or Received Calls.



Displaying the received call list.



Displaying the dialed call list.



Displaying the missed call list.

3 Touch the list number to select a phone number.

Name and phone number are displayed in the detailed list.

- If you want to store the phone number, touch and hold the list.

4 Touch the off-hook key to make the call.

5 Touch the on-hook key to end the call.

Setting automatic answering

If this function is on, this unit automatically answers all incoming calls.

- Touch the auto-answer key to turn automatic answering on or off.

Adjusting the other party's listening volume

To maintain the good sound quality, this unit can adjust the other party's listening volume. If the volume is not loud enough for the other party, use this function.

Bluetooth telephone

- Touch the volume key to select Far-End VOL.

1—2—3

- This function can be performed even while talking on the phone.
- Settings can be stored for each device.

Switching the ring tone

You can select whether or not to use this unit's ring tone. If this function is set to on, the ring tone for this unit will sound.

1 Connect your cellular phone to this unit.

2 Touch the tone key to turn the ring tone on or off.

Using the preset dial lists

You can easily store up to six phone numbers as presets.

1 Touch the preset dial key to display the preset screen.

2 Touch one of the phone numbers to select.

- If you want to delete a preset phone number, touch and hold the phone number you wish to delete.

3 Touch the off-hook key to make the call.

4 Touch the on-hook key to end the call.

Making a call by entering phone number



Important

Be sure to park your vehicle in a safe place and apply the parking brake when performing this operation.

1 Touch the key pad key to start entering the phone number.

2 Touch the number icons to input the numbers.

- Up to 24 digits can be entered.

3 Touch the off-hook key to make the call.

4 Touch the on-hook key to end the call.

Note

Entering phone number mode cannot be operated unless a Bluetooth telephone is connected to this unit.

Setting the private mode

During a conversation, you can switch to private mode (talk directly on your cellular phone).

- Touch the private mode key to turn private mode on or off.

Voice control

If your cellular phone is equipped with the voice control feature, you can use voice commands to make calls, for example.

- Operation varies depending on the type of cellular phone. Refer to the instruction manual that came with your cellular phone for detailed instructions.
- For details on cellular phone models that are compatible with this feature, refer to the information on our website.

1 Touch the voice control key.

The display switches to the voice control screen. You can also switch to the voice control screen by pressing and holding down the home button while the source is on.



2 Start voice control.

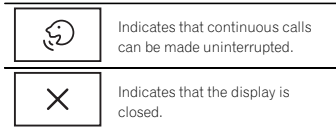

Notes

- In order for your voice commands to be recognized and interpreted correctly, ensure that conditions are suitable for recognition.

- Please note that wind blowing through the vehicle windows and noise coming from outside the vehicle can interfere with voice command operation.
- For optimum pick-up, the microphone should be placed directly in front of the driver at a suitable distance.
- Speaking too soon after the start of the command may cause voice recognition to fail.
- Speak slowly, deliberately, and clearly.

Menu operations

Touch panel keys

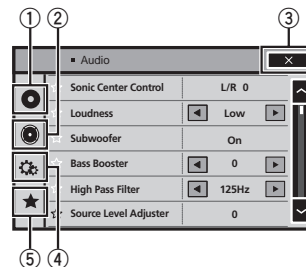

1 Video setup key

Refer to *Setting up the video player*.

2 Audio function key

Refer to *Audio adjustments*.

3 Close key

Returning to the current source display.

4 System key

Refer to *System settings*.

5 Favorite key

You can choose menu items within each menu (Audio function menu, etc.) and register them to this favorite menu. Refer to *Favorite menu*.

Notes

- You can display the **Video Setup** menu when a **Disc** source is selected.
- If you start the **Video Setup** menu, playback is stopped.

- You cannot display the Audio function menu when the mute function is on.

1 Press the home button to switch to the home display.

2 Touch any of the following touch panel keys to select the menu to be adjusted.



Audio adjustments

Using fader/balance adjustment

Fader/Balance displays when Rear Speaker is set to **Full** on the System Menu.

You can change the fader/balance setting to provide an ideal listening environment for all of the occupied seats.

1 Press the home button to switch to the home display.

2 Touch the audio function key to open the audio menu.

3 Touch **Fader/Balance** on the audio function menu.

4 Touch \wedge or \vee to adjust the front/rear speaker balance.

Range: **F 15 L/R 0** to **R 15 L/R 0**

- Select **F/R 0 L/R 0** when only using two speakers.

5 Touch \langle or \rangle to adjust the left/right speaker balance.

Range: **F/R 0 L 15** to **F/R 0 R 15**

Note

You can also set the fader/balance by dragging the dot on the displayed table.

Using balance adjustment

Balance displays when Rear Speaker is set to **Subwoofer** on the System Menu. This setting will allow you to adjust the balance between right/left sound output.

1 Press the home button to switch to the home display.

2 Touch the audio function key to open the audio menu.

3 Touch **Balance** on the audio function menu.

4 Touch \langle or \rangle to adjust the left/right speaker balance.

Range: **L 15** to **R 15**

Note

You can also set the balance by dragging the dot on the displayed table.

Using the equalizer

You can adjust the equalization to match the car's interior acoustic characteristics as desired.

Recalling equalizer curves

There are seven stored equalizer curves which you can easily recall at any time. Here is a list of the equalizer curves.

Display	Equalizer curve
S.Bass	Super bass
Powerful	Powerful
Natural	Natural
Vocal	Vocal
Flat	Flat
Custom1	Custom 1
Custom2	Custom 2

- The equalizer curves for **Custom1** and **Custom2** can be adjusted.
- You cannot select **Custom1** and **Custom2** when using the auto-equalizer.
- When **Flat**, no changes are made to the sound. You can check the effects of the equalizer curves by switching alternatively between **Flat** and another equalizer curve.

Audio adjustments

1 Press the home button to switch to the home display.

2 Touch the audio function key to open the audio menu.

3 Touch **Graphic EQ** on the audio function menu.

- You cannot select or adjust the equalizer curves of **Custom1** and **Custom2** when using the auto-equalizer.

4 Touch the desired setting.

S.Bass—Powerful—Natural—Vocal—Flat—Custom1—Custom2

Adjusting the 8-band graphic equalizer

You can adjust the level of each band for the equalizer curves.

- A separate **Custom1** curve can be created for each source. If you make adjustments when a curve other than **Custom2** is selected, the equalizer curve settings will be stored in **Custom1**.
- A **Custom2** curve that is common for all sources can be created. If you make adjustments when the **Custom2** curve is selected, the **Custom2** curve will be updated.

1 Press the home button to switch to the home display.

2 Touch the audio function key to open the audio menu.

3 Touch **Graphic EQ** on the audio function menu.

4 Touch the desired setting.

S.Bass—Powerful—Natural—Vocal—Flat—Custom1—Custom2

5 Touch the table to adjust the level of the equalizer band.

Range: **+12dB** to **-12dB**

Using the auto-equalizer

The auto-equalizer is an equalizer curve created by auto EQ (refer to *Auto EQ (auto-equalizing)*). You can turn the auto-equalizer on or off. If you connect an optional microphone to this unit, you can use this function.

1 Press the home button to switch to the home display.

2 Touch the audio function key to open the audio menu.

3 Touch **Auto EQ** to turn the auto-equalizer on or off.

- You cannot use this function if auto EQ has not been carried out.

Using sonic center control

Sound that is suited for the listening position can easily be created with this function.

1 Press the home button to switch to the home display.

2 Touch the audio function key to open the audio menu.

3 Touch **Sonic Center Control** on the audio function menu.

4 Touch \langle or \rangle to select a listening position.
Range: **Left 7** to **Right 7**

Audio adjustments

Adjusting loudness

Loudness compensates for deficiencies in the low-frequency and high-frequency ranges at low volume.

- 1 Press the home button to switch to the home display.
- 2 Touch the audio function key to open the audio menu.
- 3 Touch ◀ or ▶ to select a desired level for loudness.
Off (off)—Low (low)—Mid (mid)—High (high)

Using subwoofer output

This unit is equipped with a subwoofer output which can be turned on or off.

- The cut-off frequency and output level can be adjusted when the subwoofer output is on.

- 1 Press the home button to switch to the home display.
- 2 Touch the audio function key to open the audio menu.
- 3 Touch Subwoofer on the audio function menu.
- 4 Touch On or Off next to Subwoofer to turn the subwoofer output on or off.
- 5 Touch Normal or Reverse next to Phase to select the phase of subwoofer output.
- 6 Touch ◀ or ▶ next to Level to adjust the output level of the subwoofer.
Range: +6 to -24

- 7 Touch ◀ or ▶ next to Frequency to select the cut-off frequency.

50Hz—63Hz—80Hz—100Hz—125Hz

Only frequencies lower than those in the selected range are outputted from the subwoofer.

Boosting the bass

You can boost the bass level.

- 1 Press the home button to switch to the home display.
- 2 Touch the audio function key to open the audio menu.
- 3 Touch ◀ or ▶ to select a desired level.
Range: 0 to +6

Using the high pass filter

When you do not want low sounds from the subwoofer output frequency range to play from the front or rear speakers, turn on the HPF (high pass filter). Only frequencies higher than those in the selected range are output from the front or rear speakers.

- 1 Press the home button to switch to the home display.
- 2 Touch the audio function key to open the audio menu.
- 3 Touch ◀ or ▶ next to the frequency to select cut-off frequency.
Off (off)—50Hz—63Hz—80Hz—100Hz—125Hz
Only frequencies higher than those in the selected range are output from the front or rear speakers.

Audio adjustments

Adjusting source levels

With SLA (source level adjustment), the volume levels of each source can be adjusted to prevent significant differences between sources.

- Settings are based on the FM volume level, which remains unchanged.

- 1 Press the home button to switch to the home display.
- 2 Touch the audio function key to open the audio menu.
- 3 Compare the FM volume level with the level of the source you wish to adjust.
- 4 Touch Source Level Adjuster on the audio function menu.
- 5 Touch ^ or v to adjust the source volume.
Range: +4 to -4

Notes

- Source Level Adjuster is not available when FM is selected as the source.
- The AM volume level can also be adjusted with this function.
- Video CD, CD, compressed audio, DivX, MPEG-1, MPEG-2 and MPEG-4 are automatically set to the same source level adjustment volume.

Setting up the video player

Setting the subtitle language

You can set a desired subtitle language. When available, the subtitles will be displayed in the selected language.

1 Press the home button to switch to the home display.

2 Touch the video setup key to open the video setup menu.

3 Touch Subtitle Language on the Video Setup menu.

A subtitle language menu is displayed.

4 Touch the desired language.

The subtitle language is set.

- If you have selected **Others**, refer to *When you select Others*.

Notes

- If the selected language is not available, the language specified on the disc is displayed.
- You can also switch the subtitle language by touching the switch subtitle languages key during playback.
- The setting made here will not be affected even if the subtitle language is switched during playback using the switch subtitle languages key.

When you select Others

A language code input display is shown when **Others** is selected. Refer to *Language code chart for DVD*.

- **Touch 0 to 9 to input the language code.**
 - To cancel the entered numbers, touch **C**.
 - To register the code, touch the following touch panel key.



Registering the code.

Setting the audio language

You can set the preferred audio language.

1 Press the home button to switch to the home display.

2 Touch the video setup key to open the video setup menu.

3 Touch Audio Language on the Video Setup menu.

An audio language menu is displayed.

4 Touch the desired language.

The audio language is set.

- If you have selected **Others**, refer to *When you select Others*.

Notes

- If the selected language is not available, the language specified on the disc is used.
- You can also switch the audio language by touching the switch audio languages key during playback.
- The setting made here will not be affected even if the audio language is switched during playback using the switch audio languages key.

Setting the menu language

You can set the preferred language in which the menus recorded on a disc are displayed.

1 Press the home button to switch to the home display.

Setting up the video player

2 Touch the video setup key to open the video setup menu.

3 Touch Menu Language on the Video Setup menu.

A menu language menu is displayed.

4 Touch the desired language.

The menu language is set.

- If you have selected **Others**, refer to *When you select Others*.

Note

If the selected language is not available, the language specified on the disc is displayed.

Setting the multi-angle DVD display

The angle icon can be set so it appears on scenes where the angle can be switched.

1 Press the home button to switch to the home display.

2 Touch the video setup key to open the video setup menu.

3 Touch Multi Angle on the Video Setup menu to turn angle icon display on or off.

Setting the aspect ratio

There are two kinds of display: a wide screen display that has a width-to-height ratio (TV aspect ratio) of 16:9, and regular display that has a TV aspect of 4:3. Be sure to select the correct TV aspect for the display connected to **V OUT**.

- When using regular display, select either **Letter Box** or **Pan Scan**. Selecting **16:9** may result in an unnatural picture.
- If you select the TV aspect ratio, the unit's display will change to the same setting.

1 Press the home button to switch to the home display.

2 Touch the video setup key to open the video setup menu.

3 Touch TV Aspect on the Video Setup menu to select the TV aspect ratio.

Touch **TV Aspect** repeatedly until the desired aspect ratio appears.

- **16:9** – Wide screen picture (16:9) is displayed as is (initial setting)
- **Letter Box** – The picture is the shape of a letterbox with black bands on the top and bottom of the screen
- **Pan Scan** – The picture is cut short on the right and left sides of the screen

Notes

- When playing discs that do not specify **Pan Scan**, the disc is played back in **Letter Box** display even if you select the **Pan Scan** setting. Confirm whether the disc package bears the **16:9 LB** mark.
- The TV aspect ratio cannot be changed for some discs. For details, refer to the disc's instructions.

Setting parental lock

Some DVD video discs let you use parental lock to restrict children from viewing violent and adult-oriented scenes. You can set parental lock to the desired level.

- When you have a parental lock level set and play a disc featuring parental lock, code number input indications may be displayed. In such cases, playback will begin when the correct code number is entered.

Setting the code number and level

A code number must be registered in order to play back discs with parental lock.

Setting up the video player

- 1 Press the home button to switch to the home display.
- 2 Touch the video setup key to open the video setup menu.
- 3 Touch Parental on the Video Setup menu.
- 4 Touch 0 to 9 to input a four digit code number.
 - To cancel the entered numbers, touch **C**.
 - To register the code, touch the following touch panel key.



Registering the code.

The code number is set, and the level can now be set.

- 5 Touch 1 to 8 to select the desired level.

- 6 Touch Enter.

The parental lock level is set.

- **8** – Playback of the entire disc is possible (initial setting)
- **7 to 2** – Playback of discs for children and non-adult-oriented discs is possible
- **1** – Playback of discs for children only is possible

Notes

- We recommend to keep a record of your code number in case you forget it.
- The parental lock level is stored on the disc package, included literature or on the disc itself. Parental lock of this unit is not possible if a parental lock level is not stored on the disc.

- With some discs, the parental lock may be active only for certain levels of scenes. The playback of those scenes will be skipped. For details, refer to the instruction manual that came with the disc.

Changing the level

You can change the set parental lock level.

- 1 Press the home button to switch to the home display.
- 2 Touch the video setup key to open the video setup menu.
- 3 Touch Parental on the Video Setup menu.
- 4 Touch 0 to 9 to input the registered code number.
- 5 Registering the code.



Registering the code.

This sets the code number, and the level can now be changed.

- If you enter an incorrect code number, the  icon is displayed. Touch **C** and enter the correct code number.
- If you forget your code number, refer to *If you forget your code number*.

- 6 Touch 1 to 8 to select the desired level.

- 7 Touch Enter.

The new parental lock level is set.

If you forget your code number

- Press **RESET**.

Setting up the video player

Setting the DivX subtitle file

You can select whether or not to display DivX external subtitles.

- The DivX subtitles will be displayed even when **Custom** is selected if no DivX external subtitle files exist.

- 1 Press the home button to switch to the home display.
- 2 Touch the video setup key to open the video setup menu.
- 3 Touch DivX® Subtitle on the Video Setup menu to select the desired subtitle setting.
 - **Original** – Display the DivX subtitles
 - **Custom** – Display the DivX external subtitles

Notes

- Up to 42 characters can be displayed on one line. If more than 42 characters are set, the line breaks and the characters are displayed on the next line.
- Up to 126 characters can be displayed on one screen. If more than 126 characters are set, the excess characters will not be displayed.

Displaying the DivX® VOD registration code

In order to play DivX VOD (video on demand) contents on this unit, the unit must first be registered with a DivX VOD contents provider. For registration, generate a DivX VOD registration code and submit it to your provider.

- Keep a record of the code as you will need it when you register your unit to the DivX VOD provider.

- 1 Press the home button to switch to the home display.
- 2 Touch the video setup key to open the video setup menu.

- 3 Touch DivX® VOD on the Video Setup menu.

Registration Code and **Deregistration Code** appear.

- 4 Touch **Registration Code**.

Your registration code is displayed.

Displaying the deregistration code

If your device is already registered, deregister it by entering the deregistration code.

- 1 Press the home button to switch to the home display.
- 2 Touch the video setup key to open the video setup menu.

- 3 Touch DivX® VOD on the Video Setup menu.

- 4 Touch **Deregistration Code**.
 - To cancel deregistration, touch **Cancel**.

- 5 Touch **OK**.

The deregistration is complete.

Automatic playback of DVDs

When a DVD disc with a DVD menu is inserted, this unit will cancel the menu automatically and start playback from the first chapter of the first title.

- Some DVDs may not operate properly. If this function is not fully operable, turn this function off and start playback.

- 1 Press the home button to switch to the home display.
- 2 Touch the video setup key to open the video setup menu.
- 3 Touch **DVD Auto Play** to turn automatic playback on.
 - To turn automatic playback off, touch **DVD Auto Play** again.

System settings

Switching the auxiliary setting

Activate this setting when using an auxiliary device connected to this unit.

- 1 Press the home button to switch to the home display.
- 2 Touch the system key to open the system menu.
- 3 Touch AUX Input on the system menu to turn AUX Input on or off.

Setting AV input

Activate this setting when using an external video component connected to this unit.

- 1 Press the home button to switch to the home display.
- 2 Touch the system key to open the system menu.
- 3 Touch AV Input on the system menu to turn AV Input on or off.

Setting the RGB Input

Settings are required according to the connected device.

RGB Input can be set when all of the following conditions are met.

- The iPhone is not connected to RGB input.
- No Bluetooth connection.
- The source is turned off.

1 Turn the source off.

Refer to *Turning the source ON/OFF*.

- 2 Press the home button to switch to the home display.

- 3 Touch the system key to open the system menu.

- 4 Touch RGB Input on the system menu to select the RGB input.

- 5 Touch the desired setting.

- **iPhone (CD-IU201S)** – iPod with 30-pin connector
- **iPhone (VGA adapter)** – iPod with lightning connector
- **NAVI** – Navigation system

Setting the Pandora connect mode

Refer to *Setting the Pandora connect mode*.

Setting the App sound mixing

Refer to *Setting the App sound mixing*.

Setting MIXTRAX mode

Refer to *Setting MIXTRAX mode*.

Changing the picture adjustment

You can adjust the **Brightness** (brightness), **Contrast** (contrast), **Color** (color), **Hue** (hue), **Dimmer** (dimmer), and **Temperature** (temperature) for each source and rear view camera.

- You cannot adjust **Color** or **Hue** for the audio source.

- 1 Press the home button to switch to the home display.

System settings

- 2 Touch the system key to open the system menu.

- 3 If you are adjusting the **Picture Adjustment**, select the unit.

NAVI

Completing **Picture Adjustment** for the Navigation system when the RGB input setting is set to **NAVI**.

Apps

Completing **Picture Adjustment** for the **AppRadio Mode** when the RGB input setting is set to **iPhone (CD-IU201S)** or **iPhone (VGA adapter)**.

Rear View

Adjusting the **Picture Adjustment** for the rear view camera.

Source

Adjusting the **Picture Adjustment** for the source.

- 4 Touch any of the following touch panel keys to select the function to be adjusted.

Picture Adjustment items are displayed.

- **Brightness** – Adjusts the black intensity
- **Contrast** – Adjusts the contrast
- **Color** – Adjusts the color saturation
- **Hue** – Adjusts the tone of color (red or green is emphasized)
- **Dimmer** – Adjusts the brightness of the display
- **Temperature** – Adjusts the color temperature, resulting in a better white balance
 - You can adjust **Hue** only when the color system is set to NTSC.
 - With some rear view cameras, picture adjustment may not be possible.

- 5 Touch ◀ or ▶ to adjust the selected item.

Each time you touch ◀ or ▶, the level of the selected item increases or decreases.

- **Dimmer** can be adjusted from +1 to +48.
- **Temperature** can be adjusted from +3 to –3.

Notes

- You cannot operate this function while driving.
- Different **Brightness/Contrast/Dimmer** settings can be set for when the illumination switch is on and when it is off.

Selecting the system language

The system language can be selected.

If text information such as the title name, artist name or a comment is embedded in a European language, they can also be displayed on this unit.

- The language can be changed for the following:
 - Audio menu
 - System menu
 - Video Setup menu
 - Bluetooth menu
 - Language for cautions
- Some operations on this unit are prohibited from use while driving or require careful attention when operated. In such cases, a caution will appear on the display. You can change the language for caution messages with this setting.
- If the embedded language and the selected language setting are not the same, text information may not display properly.
- Some characters may not be displayed properly.

- 1 Press the home button to switch to the home display.

- 2 Touch the system key to open the system menu.

- 3 Touch **System Language** on the system menu to select the desired language.

System settings

4 Touch the desired language.

English (English)—**Français** (French)—**Español** (Spanish)—**Português** (Portuguese)—**中文** (Simplified Chinese)

Setting Demo Mode

Once Demo Mode is turned on, the Demo screen appears. Refer to *Demo mode*.

- 1 Press the home button to switch to the home display.
- 2 Touch the system key to open the system menu.
- 3 Touch Demo mode on the system menu to turn Demo mode on or off.
 - **On** – The Demo screen appears.
 - **Off** – The Demo screen does not appear.

Switching sound muting/attenuation

Sound from this system is automatically muted or attenuated when a signal from equipment with a mute function is received.

- Sound from this system returns to normal when the muting or attenuation is canceled.

- 1 Press the home button to switch to the home display.
- 2 Touch the system key to open the system menu.
- 3 Touch Mute/ATT until the desired setting appears. Touch **Mute/ATT** until the desired setting appears in the display.
 - **Mute** – Muting

- **ATT –20dB** – Attenuation (**ATT –20dB** has a stronger effect than **ATT –10dB**)
- **ATT –10dB** – Attenuation
- **Off** – Turns the sound muting/attenuation off

Notes

- When **Mute** is displayed, the sound is turned off and no audio adjustments can be made.
- When **ATT** is displayed, the sound is attenuated and only the volume can be adjusted. (No other audio adjustments can be made.)
- Operation returns to normal when the phone connection is ended.

Setting the rear output and subwoofer controller

This unit's rear output (rear speaker leads output and RCA rear output) can be used for full-range speaker (**Full**) or subwoofer (**Subwoofer**) connection. If you switch the rear output setting to **Subwoofer**, you can connect a rear speaker lead directly to a subwoofer without using an auxiliary amp. Initially, the unit is set for a rear full-range speaker connection (**Full**).

- 1 Turn the source off. Refer to *Turning the source ON/OFF*.
- 2 Press the home button to switch to the home display.
- 3 Touch the system key to open the system menu.
- 4 Touch Rear Speaker on the system menu to switch the subwoofer output or full-range speaker.
 - When no subwoofer is connected to the rear output, select **Full** (full-range speaker).
 - When a subwoofer is connected to the rear output, select **Subwoofer** (subwoofer).

System settings

Notes

- Even if you change this setting, there will be no output unless you turn the subwoofer out-put on (refer to *Using subwoofer output*).
- Both rear speaker lead outputs and RCA rear output are switched simultaneously in this setting.

Using the keyboard

Keyboard is available only in **AppRadio Mode**. Refer to *Setting the Keyboard*.

Setting the ever scroll

When ever scroll is set to **On**, recorded text information scrolls continuously in the display. Set to **Off** if you prefer the information to scroll just once.

- 1 Press the home button to switch to the home display.
- 2 Touch the system key to open the system menu.
- 3 Touch Ever Scroll on the system menu to turn ever scroll on or off.

Setting the Bluetooth audio

(Function of AVH-X7500BT)
You need to activate the **Bluetooth Audio** source in order to use a Bluetooth audio player.

- 1 Press the home button to switch to the home display.
- 2 Touch the system key to open the system menu.

3 Touch Bluetooth Audio on the system menu to turn Bluetooth audio on or off.

Clearing Bluetooth memory

🔄 Important

Never turn the unit off while the Bluetooth memory is being cleared.

- 1 Turn the source off. Refer to *Turning the source ON/OFF*.

- 2 Press the home button to switch to the home display.

- 3 Touch the system key to open the system menu.

- 4 Touch Bluetooth Memory Clear on the system menu.

- 5 Touch Clear. After selecting a desired item, a confirmation display appears. Touch **OK** to delete the memory.
 - If you do not want to clear the memory, touch **Cancel**.

Updating Bluetooth connection software

This function is used to update this unit with the latest Bluetooth software. For about Bluetooth software and updating, refer to our website.

🔄 Important

Never turn the unit off and never disconnect the phone while the software is being updated.

- 1 Turn the source off. Refer to *Turning the source ON/OFF*.

System settings

- 2 Press the home button to switch to the home display.
- 3 Touch the system key to open the system menu.
- 4 Touch BT Software Update.
- 5 Touch Start to display the data transfer mode.
 - Follow the on-screen instructions to finish updating the Bluetooth software.

Displaying the Bluetooth system version

If this unit fails to operate properly, you may need to consult your dealer for repair. In such cases, you may be asked to specify the system version. Perform the following procedure to check the version on this unit.

- 1 Turn the source off.
Refer to *Turning the source ON/OFF*.
- 2 Press the home button to switch to the home display.
- 3 Touch the system key to open the system menu.
- 4 Touch Bluetooth Version Information to display to the version of the Bluetooth module of this unit.

Setting the automatic open function

Refer to *Setting the automatic open function*.

Setting the rear view camera (back up camera)



CAUTION

Pioneer recommends the use of a camera which outputs mirror-reversed images. Otherwise, the screen image will appear reversed.

This unit features a function that automatically switches to the rear view camera video (**REAR VIEW CAMERA IN**) when a rear view camera is installed on your car and the shift lever is moved to the **REVERSE (R)** position. (For more details, consult your dealer.)

You can also switch the rear view image by pressing the touch panel key.

For details refer to *Using the rear view*.

- After you set up the rear view camera setting, move the shift lever to **REVERSE (R)** and confirm that the rear view camera video is shown on the display.
- Change this setting if the display switches to the rear view camera video by error while you are driving forward.
- To stop watching the rear view camera video and return to the source display, press and hold **MUTE**.
- Touch the **RearView** icon to display the rear view camera image while driving. Touch the source icon again to turn the rear view camera off. For details, refer to *Selecting a source*.

- 1 Press the home button to switch to the home display.
- 2 Touch the system key to open the system menu.

System settings

- 3 Touch Camera Polarity on the system menu to select the appropriate setting.
 - **Battery** – When the polarity of the connected lead is positive while the shift lever is in **REVERSE (R)** position
 - **Ground** – When the polarity of the connected lead is negative while the shift lever is in **REVERSE (R)** position
 - **Off** – When a rear view camera is not connected to this unit
 - The rear view key setting also turns on from the home display screen.

Auto EQ (auto-equalizing)

The auto-equalizer automatically measures the car's interior acoustic characteristics, and then creates an auto-equalizer curve based on that information.

- To perform this function, dedicated microphone (e.g. CD-MC20) is required.



WARNING

As a loud tone (noise) may be emitted from the speakers when measuring the car's interior acoustic characteristics, never perform auto EQ while driving.



CAUTION

- Thoroughly check the conditions before performing auto EQ as the speakers may be damaged if these functions are performed when:
 - The speakers are incorrectly connected. (For example, when a rear speaker is connected as a subwoofer output.)
 - A speaker is connected to a power amp delivering output higher than the speaker's maximum input power capability.

- If the microphone is placed in an unsuitable position the measurement tone may become loud and measurement may take a long time, resulting in battery drainage. Be sure to place the microphone in the specified location.

Before operating the auto EQ function

- Carry out auto EQ in as quiet a place as possible, with the car engine and air conditioning switched off. Also cut power to car phones or portable telephones in the car, or remove them from the car before carrying out auto EQ. Sounds other than the measurement tone (surrounding sounds, engine sound, telephones ringing etc.) may prevent correct measurement of the car interior acoustic characteristics.
- Be sure to carry out auto EQ using the optional microphone. Using another microphone may prevent measurement, or result in incorrect measurement of the car interior acoustic characteristics.
- In order to perform auto EQ, the front speaker must be connected.
- When this unit is connected to a power amp with input level control, auto EQ may not be possible if the power amp's input level is set below the standard level.
- When this unit is connected to a power amp with an LPF, turn this LPF off before performing auto EQ. Also set the cut-off frequency for the built-in LPF of an active subwoofer to the highest frequency.
- The distance has been calculated by computer to be the optimum delay to give accurate results for the circumstances, so please continue to use this value.
 - The reflected sound within the car is strong and delays occur.
 - The LPF on active subwoofers or external amps delay the lower sounds.

System settings

- Auto EQ changes the audio settings as follows:
 - The fader/balance settings return to the center position. (Refer to *Using fader/balance adjustment*.)
 - The equalizer curve switches to **Flat**. (Refer to *Recalling equalizer curves*)
 - The front, center and rear speakers will automatically be adjusted to a high pass filter setting.
- Previous settings for auto EQ will be overwritten.
- Connect a microphone extension cable (sold separately) to the AUX input in advance.

Performing auto EQ

- 1 **Stop the car in a place that is quiet, close all the doors, windows and sun roof, and then turn the engine off.**

If the engine is left running, engine noise may prevent correct auto EQ.

- 2 **Fix the optional microphone in the center of the headrest of the driver's seat, facing forward.**

The auto EQ may differ depending on where you place the microphone. If desired, place the microphone on the front passenger seat to carry out auto EQ.

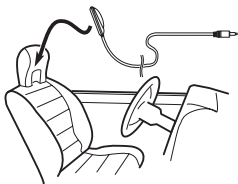

- 3 **Turn the ignition switch to ON or ACC.** If the car's air conditioner or heater is turned on, turn it off. Noise from the fan in the air conditioner or heater may prevent correct auto EQ.
- 4 **Press the home button to switch to the home display.**
- 5 **Touch the system key to open the system menu.**
- 6 **Touch Auto EQ Measurement to enter auto EQ measurement mode.**
- 7 **Plug the microphone into the AUX input jack on this unit.**

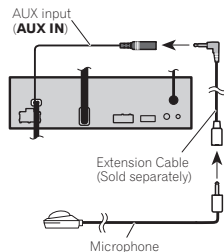

- 8 **Touch Start to start auto EQ.**
- 9 **When the 10-second countdown starts, get out of the car and close the door within 10 seconds.** A measurement tone (noise) is emitted from the speakers, and auto EQ measurement begins. When auto EQ is completed, **The measurement has finished. Please disconnect the microphone and then push HOME key.** is displayed.

System settings

When the car's interior acoustic characteristics cannot be measured correctly, an error message will be displayed. (Refer to *Understanding auto EQ error messages*.)

- It takes about nine minutes for auto EQ measurement to be completed when all the speakers are connected.
- To stop auto EQ, touch **Stop**.

- 10 **Store the microphone carefully in the glove compartment or another safe place.**

If the microphone is subjected to direct sunlight for an extended period, high temperatures may cause distortion, color change or malfunction.

Setting the video signal

When you connect this unit to an AV equipment to this unit, select the suitable video signal setting.

- As this function is initially set to **Auto**, the unit will automatically adjust the video signal setting.
- You can operate this function only for the video signal input into the AV input.

- 1 **Press the home button to switch to the home display.**
- 2 **Touch the system key to open the system menu.**
- 3 **Touch Video Signal Setting on the function menu.** **Video Signal Setting** items are displayed.
 - **AV** – Adjusts the AV video signal
 - **AUX** – Adjusts the AUX video signal
 - **Camera** – Adjusts the rear view camera video signal
- 4 **Touch ◀ or ▶ to select the desired video signal appears.**
Auto—PAL—NTSC—PAL-M—PAL-N—SECAM

Favorite menu

Using the Favorite menu

1 Display menu columns to register. Refer to *Menu operations*.

- You can customize menus except **Video Setup** menu.

2 Touch the star icon in the menu column for the desired menu to register the menu. The star icon for the selected menu is filled in.

- To cancel the registration, touch the star icon in the menu column again.

3 Display the favorite menu and choose a registered menu.

Refer to *Menu operations*.

Note

You can register up to 12 columns.

Bluetooth connection menu

Bluetooth connection menu operations

(Function of AVH-X7500BT)

If you are using a cellular phone that can be connected via Bluetooth wireless technology, we recommend that you use your phone to search for this unit and establish a connection between it and your phone. The PIN code is set to **0000** as default. The product name for this unit will display on your phone as the device name. For details, refer to *Entering PIN code for Bluetooth wireless connection*. For further details concerning the procedures for establishing Bluetooth wireless connections, refer to the instruction manual for the phone.

Pairing from this unit

1 Press the home button to switch to the home display.

2 Touch the Bluetooth key to open the Bluetooth connection menu.

3 Touch Connection to select a device.

4 Start to search.



Starting to search.

While searching,  is displayed and when available devices are found, the device names or Bluetooth device addresses (if names cannot be obtained) are displayed.

- If you want to switch between the device names and Bluetooth device addresses, touch the icon.



Switching between the device names and Bluetooth device addresses.

- To cancel searching, touch **Stop**.
- If three devices are already paired, **Memory Full** is displayed and pairing cannot be performed. In such cases, delete a paired device first. Refer to page 37.
- If no device can be found, **Not Found** is displayed. In such cases, check the status of the Bluetooth device and search again.

5 Touch a device name to select the device you want to connect to.

While connecting, **Pairing** is displayed. If the connection is established, **Paired** is displayed.

- If your device support SSP (Secure Simple Pairing), six-digit number appears on the display of this unit. Once the connection is established, this number disappears.
- If the connection fails, **Error** is displayed. In such cases, try again from the beginning.
- The PIN code is set to **0000** as the default, but can be changed. Refer to *Entering PIN code for Bluetooth wireless connection*.
- Once the connection is established, the device name is displayed.

Touch the device name to disconnect.

- If you want to delete a paired Bluetooth telephone, display **Delete OK?**. Touch **Yes** to delete the device.



Deleting a paired device.

- Never turn the unit off while the paired Bluetooth telephone is being deleted.

Bluetooth connection menu

Connecting to a Bluetooth device automatically

If this function is set to on, a connection between your Bluetooth device and this unit will take place automatically as soon as the two devices are less than a few meters apart. Initially, this function is set to on.

- 1 Press the home button to switch to the home display.
- 2 Touch the Bluetooth key to open the Bluetooth connection menu.
- 3 Touch Auto Connect to turn automatic connection on.

If your Bluetooth device is ready for a Bluetooth wireless connection, a connection to this unit will automatically be established.

▪ To turn automatic connection off, touch Auto Connect again.

If connection fails, "Auto connection failed. Retry?" appears. Touch Yes to reconnect.

- 4 Once you turn your vehicle's ACC switch on again, a connection is established automatically.

Switching visible unit

This function sets whether or not to make this unit visible to the other device. Initially, this function is set to on.

- 1 Press the home button to switch to the home display.
- 2 Touch the Bluetooth key to open the Bluetooth connection menu.
- 3 Touch Visibility to select visibility off.
 - To turn visibility on, touch Visibility again.

Entering PIN code for Bluetooth wireless connection

To connect your Bluetooth device to this unit via Bluetooth wireless technology, you need to enter a PIN code on your Bluetooth device to verify the connection. The default code is 0000, but you can change it with this function.

- 1 Press the home button to switch to the home display.
- 2 Touch the Bluetooth key to open the Bluetooth connection menu.
- 3 Touch PIN Code Input to select PIN Code Input.
- 4 Touch 0 to 9 to input pin code.
- 5 After inputting PIN code (up to 8 digits), store in this unit.



Storing the PIN code in this unit.

Displaying Bluetooth Device address

This unit displays its Bluetooth device address.

- 1 Press the home button to switch to the home display.
- 2 Touch the Bluetooth key to open the Bluetooth connection menu.
- 3 Touch Device Information to display device information.

The Bluetooth device address is displayed.

Theme menu

Selecting the illumination color

This unit is equipped with multiple-color illumination.

Direct selection from preset illumination colors

You can select an illumination color from the color list.

- 1 Press the home button to switch to the home display.
- 2 Touch the theme key to open the theme settings.
- 3 Touch Illumination and then touch a color on the list.

Customizing the illumination color

- 1 Press the home button to switch to the home display.
- 2 Touch the theme key to open the theme settings.
- 3 Touch Illumination and then touch Custom.
- 4 Display the customizing menu.



Displaying the customizing menu.

- 5 Touch the color bar to customize the color.
- 6 Touch ◀ or ▶ to fine-tune the color.

- 7 Touch and hold the icon to store the customized color in the memory.

Memo

Storing the customized color in the memory.

The customized color has been stored in the memory. The set color will be recalled from the memory the next time you touch the same icon.

Selecting the OSD (on-screen display) color

The OSD color can be changed.

- 1 Press the home button to switch to the home display.
- 2 Touch the theme key to open the theme settings.
- 3 Touch Screen.
- 4 Touch one of the colors on the list.

Selecting the background display

You can switch the background that is displayed when listening to a source.

- 1 Press the home button to switch to the home display.
- 2 Touch the theme key to open the theme settings.
- 3 Touch Background.
- 4 Touch the desired setting.
 - You can view the hidden settings by flicking the display.

Other functions

Adjusting the response positions of the touch panels (Touch Panel Calibration)

If you feel that the touch panel keys on the screen deviate from the actual positions that respond to your touch, adjust the response positions of the touch panel. There are two adjustment methods: four-point adjustment, in which you touch four corners of the screen; and 16-point adjustment, in which you make fine-adjustments on the entire screen.

- Park your car in a safe place and use this function. Do not operate it while driving.
- Touch the screen gently for adjustment. Forcefully pressing the touch panel may damage the touch panel. Do not use a sharp pointed tool such as a ballpoint pen or mechanical pen. Doing so may damage the screen.
- If the touch panel cannot be adjusted properly, consult your local Pioneer dealer.

1 Turn the source off.

Refer to *Turning the source ON/OFF*.

2 Press and hold the home button to start Touch Panel Calibration.

The four-point touch panel adjustment screen appears. When two-point appears at once, touch both.

3 Touch each of the arrows on the four corners of the screen.

- To cancel the adjustment, press and hold the home button.

4 Press the home button to complete four-point adjustment.

Data for the adjusted position is saved.

- Do not turn off the engine while the data is being saved.

5 Press the home button to proceed to 16-point adjustment.

The 16-point touch panel adjustment screen appears.

- To cancel the adjustment, press and hold the home button.

6 Gently touch the center of the + mark displayed on the screen.

After you touch all the marks, the data for the adjusted position is saved.

- Do not turn off the engine while the data is being saved.

7 Press and hold the home button to complete the adjustment.

Using an AUX source

An auxiliary device or portable device sold separately can be connected to this unit.

About AUX connection methods

You can connect auxiliary devices to this unit.

Mini pin plug cable (AUX)

When connecting an auxiliary device using a mini plug cable

- iPods and portable audio/video players can be connected to this unit via mini plug cable.
- If an iPod with video capabilities is connected to this unit via 3.5 mm plug (four pole) cable (such as the CD-V150M), you can enjoy the video contents of the connected iPod.
 - A portable audio/video player can be connected by using a 3.5 mm plug (four pole) with an RCA cable (sold separately). However, depending on the cable, a reverse connection between the red (right side audio) cable and yellow (video) cable may be required in order for the sound and video image to be reproduced correctly.

Other functions

● Insert the stereo mini plug into the AUX input jack on this unit.

Refer to *Connection*.

Resetting the microprocessor

By pressing **RESET**, you can reset the microprocessor to its initial settings without changing the bookmark information.

The microprocessor must be reset in the following situations:

- Before using this unit for the first time after installation
- If the unit fails to operate properly
- When strange or incorrect messages appear on the display

1 Turn the ignition switch OFF.

2 Press RESET with a pen tip or other pointed instrument.

Refer to *What's what*.

Note

Switch your engine ON or set the ignition switch to ACC ON before pressing **RESET** in the following situations:

- After completing connections
- When erasing all stored settings
- When resetting the unit to its initial (factory) settings

Connection

⚠ WARNING

- In some countries or states the viewing of images on a display inside a vehicle even by persons other than the driver may be illegal. Where such regulations apply, they must be obeyed and this unit's DVD features should not be used.

⚠ CAUTION

- Do not drill a hole into the engine compartment to connect the yellow cable of the display unit to the vehicle battery. Engine vibration may eventually cause the insulation to fail at the point where the wire passes from the passenger compartment into the engine compartment. Take extra care in securing the wire at this point.
- Make sure that cables will not interfere with moving parts of the vehicle, such as the shift lever, parking brake or seat sliding mechanism.

⚠ WARNING

- Use speakers over 50 W (output value) and between 4 Ω to 8 Ω (impedance value). Do not use 1 Ω to 3 Ω speakers for this unit.

- The black cable is ground. When installing this unit or power amp (sold separately), make sure to connect the ground wire first. Make sure that the ground cable is properly connected to metal parts of the car body using a spade terminal sold commercially. The ground wire of the power amp and the one of this unit or any other device must be connected to the car separately with different screws. If the screw for the ground wire loosens or falls out, it could result in fire, generation of smoke or malfunction.

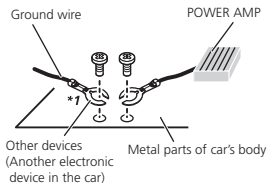

*1 Not supplied for this unit

🔑 Important

- This unit cannot be installed in a vehicle without ACC (accessory) position on the ignition switch.



ACC position



No ACC position

- Use this unit with a 12-volt battery and negative grounding only. Failure to do so may result in a fire or malfunction.
- To prevent a short-circuit, overheating or malfunction, be sure to follow the directions below.
 - Disconnect the negative terminal of the battery before installation.

Connection

- Secure the wiring with cable clamps or adhesive tape. Wrap adhesive tape around wiring that comes into contact with metal parts to protect the wiring.
- Place all cables away from moving parts, such as the shift lever and seat rails.
- Place all cables away from hot places, such as near the heater outlet.
- Do not connect the yellow cable to the battery by passing it through the hole to the engine compartment.
- Cover any disconnected cable connectors with insulating tape.
- Do not shorten any cables.
- Never cut the insulation of the power cable of this unit in order to share the power with other devices. The current capacity of the cable is limited.
- Use a fuse of the rating prescribed.
- Never wire the negative speaker cable directly to ground.
- Never band together negative cables of multiple speakers.
- When this unit is on, control signals are sent through the blue/white cable. Connect this cable to the system remote control of an external power amp or the vehicle's auto-antenna relay control terminal (max. 300 mA 12 VDC). If the vehicle is equipped with a glass antenna, connect it to the antenna booster power supply terminal.
- Never connect the blue/white cable to the power terminal of an external power amp. Also, never connect it to the power terminal of the auto antenna. Doing so may result in battery drain or a malfunction.

Connection

Connection

Connecting the power cord

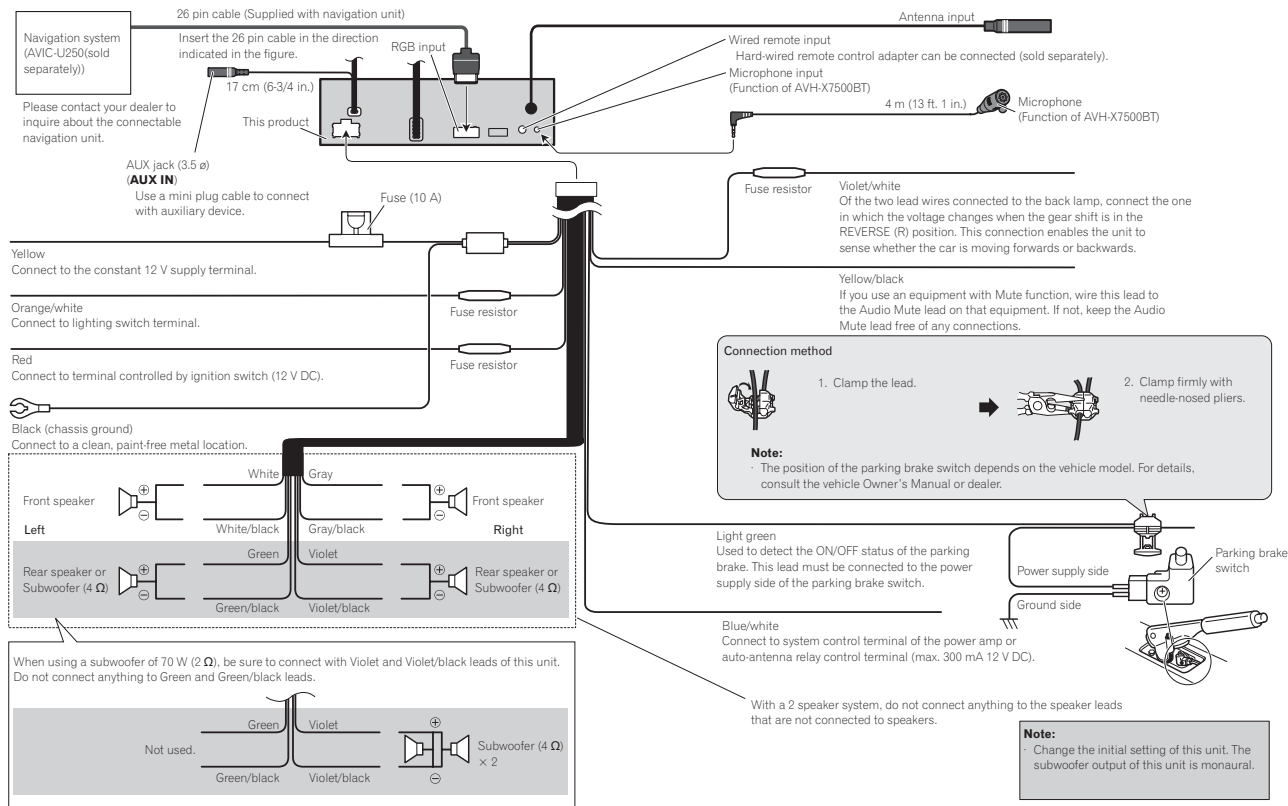

Connection

When connecting to separately sold power amp

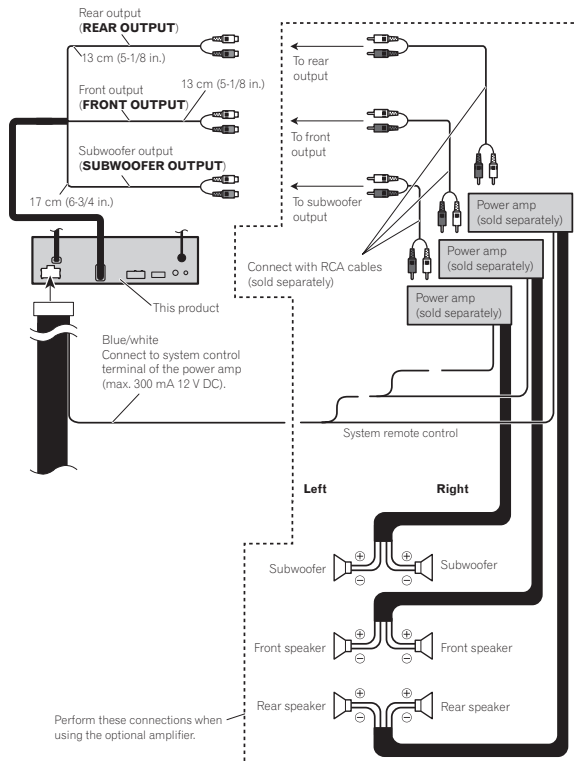

Connection

When connecting the external video component and the display

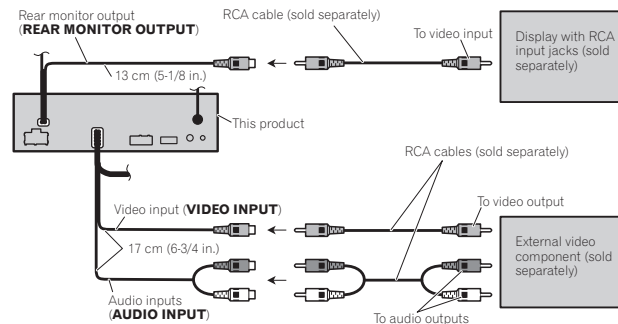

- It is necessary to change **AV Input** in the system menu when connecting the external video component. Refer to *Setting AV input*.

This product's rear video output is for connection of a display to enable passengers in the rear seats to watch the DVD, etc.

⚠ WARNING

- Never install a rear display in a location that is visible to the driver while the vehicle is in motion.

Connection

When connecting with a rear view camera

If you switch the shift lever to REVERSE (R), the display on this unit will automatically switch to the rear view image. You need to set the **Camera Polarity** properly in the system unit to use. For details on settings, refer to *Setting the rear view camera (back up camera)*. You can also switch to the rear view image by pressing the touch panel key. For details, refer to *Using the rear view*.

WARNING
USE INPUT ONLY FOR REVERSE OR MIRROR IMAGE REAR VIEW CAMERA. OTHER USE MAY RESULT IN INJURY OR DAMAGE.

CAUTION

- You must use a camera which outputs mirror reversed images.
- The screen image may appear reversed.
- The rear view camera function is to be used as an aid to keep an eye on trailers, or while backing up. Do not use for entertainment purposes.
- Objects in the rear view may appear closer or more distant than they actually are.

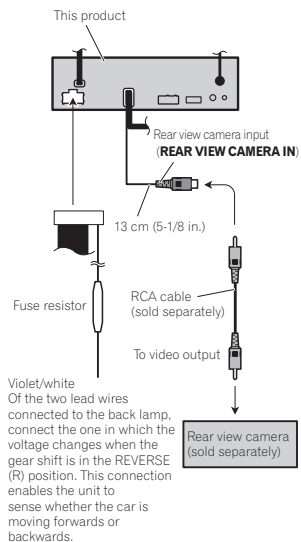

Connection

iPod with lightning connector

When connecting with optional Lightning to USB Cable

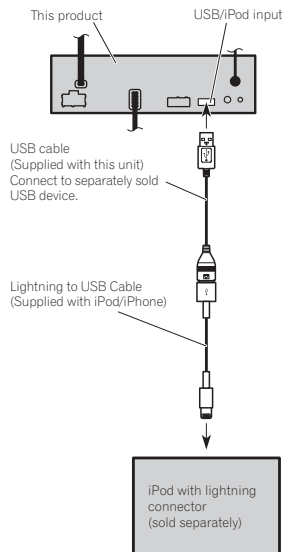

When connecting with optional CD-IV202AV cable

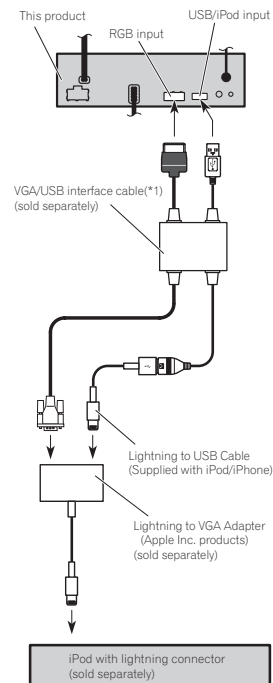

(*1)
 For details of how to connect the separately sold VGA/USB interface cable (CD-IV202AV), refer to the VGA/USB interface cable manual.

Connection

iPod with 30-pin connector When connecting with optional CD-IU201V cable

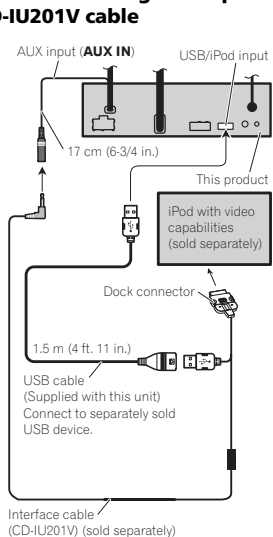

When connecting with optional CD-IU201S cable

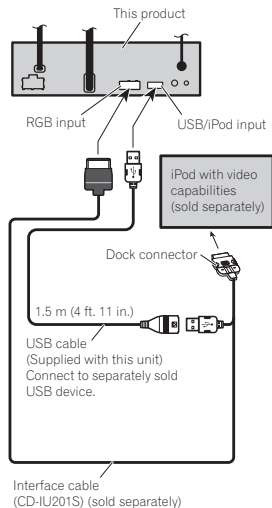

Installation

Notes

- Check all connections and systems before final installation.
- Do not use unauthorized parts as this may cause malfunctions.
- Consult your dealer if installation requires drilling of holes or other modifications to the vehicle.
- Do not install this unit where:
 - it may interfere with operation of the vehicle.
 - it may cause injury to a passenger as a result of a sudden stop.
- The semiconductor laser will be damaged if it overheats. Install this unit away from hot places such as near the heater outlet.
- Optimum performance is obtained when the unit is installed at an angle of less than 30°.



- When installing, to ensure proper heat dispersal when using this unit, make sure you leave ample space behind the rear panel and wrap any loose cables so they are not blocking the vents.

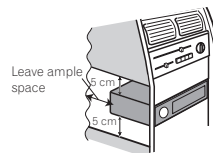

- The cords must not cover up the area shown in the figure below. This is necessary to allow the amplifiers to radiate freely.



- 1 Do not cover this area.
- Make sure you leave enough gap between the dashboard and the LCD panel of this unit so the LCD panel can be opened and closed without contacting with the dashboard.

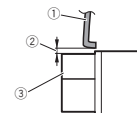

- 1 Dashboard
- 2 Leave gap
- 3 LCD panel

DIN front/rear-mount

This unit can be properly installed using either front-mount or rear-mount installation. Use commercially available parts when installing.

DIN Front-mount

- 1 **Decide the position of the side brackets.** When installing in a shallow space, change the position of side brackets (small).

Installation

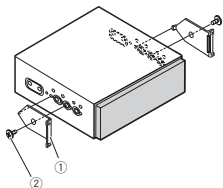

- ① Side bracket (small)
- ② Flush surface screw (5 mm × 6 mm)

2 Install the unit into the dashboard.

Insert the mounting sleeve into the dashboard. And then secure the mounting sleeve by using a screwdriver to bend the metal tabs (90°) into place.

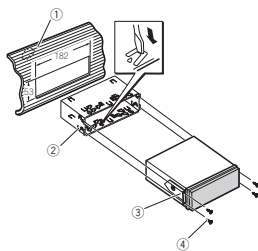

- ① Dashboard
- ② Mounting sleeve
- ③ Side bracket
- ④ Screw (2 mm × 3 mm)

DIN Rear-mount

1 Determine the appropriate position where the holes on the bracket and the side of the unit match.

When installing in a shallow space, use the following screw holes.

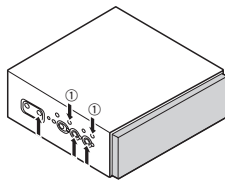

- ① Use binding screws (4 mm × 3 mm) only.

2 Tighten two screws on each side.

Use any of binding screws (4 mm × 3 mm), binding screws (5 mm × 6 mm) or flush surface screws (5 mm × 6 mm), depending on the shape of screw holes in the bracket.

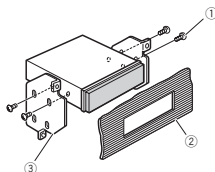

- ① Screw
- ② Dashboard or console
- ③ Factory radio mounting bracket

Note

In some types of vehicles, discrepancy may occur between the unit and the dashboard. If this happens, use the supplied frame to fill the gap.

Removing the unit

Extend top and bottom of the trim ring outwards to remove the trim ring. And then loosen the screws (2 mm × 3 mm) to remove the mounting sleeve.

Installation

- When reattaching the trim ring, push the trim ring onto the unit until it clicks. (If the trim ring is attached upside down, the trim ring will not fit properly.)

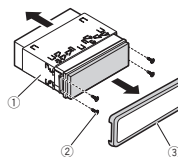

- ① Mounting sleeve
- ② Screw (2 mm × 3 mm)
- ③ Trim ring

Fastening the front panel

If you do not plan to detach the front panel, the front panel can be fastened with supplied screw.

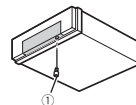

- ① Screw

Installing the microphone

(Function of AVH-X7500BT)

⚠ CAUTION

It is extremely dangerous to allow the microphone lead to become wound around the steering column or shift lever. Be sure to install the unit in such a way that it will not obstruct driving.

Note

Install the microphone in a position and orientation that will enable it to pick up the voice of the person operating the system.

When installing the microphone on the sun visor

1 Fit the microphone lead into the groove.

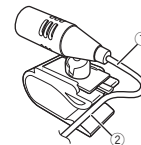

- ① Microphone lead
- ② Groove

2 Install the microphone clip on the sun visor.

With the sun visor up, install the microphone clip. (Lowering the sun visor reduces the voice recognition rate.)

Installation

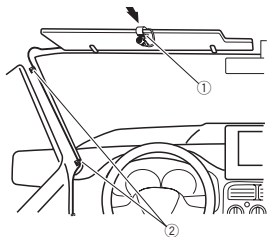

- ① Microphone clip
 - ② Clamp
- Use separately sold clamps to secure the lead where necessary inside the vehicle.

When installing the microphone on the steering column

1 Detach the microphone base from the microphone clip.

To detach the microphone base from the microphone clip, slide the microphone base.

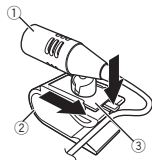

- ① Microphone
- ② Microphone clip
- ③ Microphone base

2 Install the microphone on the steering column.



- ① Double-sided tape
 - ② Install the microphone on the rear side of the steering column.
 - ③ Clamp
- Use separately sold clamps to secure the lead where necessary inside the vehicle.

Adjusting the microphone angle



The microphone angle can be adjusted.

Additional information

Troubleshooting

Common

Symptom	Cause	Action (Reference page)
The power will not turn on. The unit will not operate.	Leads and connectors are incorrectly connected. The fuse is blown.	Confirm once more that all connections are correct. Rectify the cause and then replace the fuse. Be sure to install a fuse with the same rating.
Noise and/or other factors are causing the built-in micro-processor to operate incorrectly.		Press RESET . (Page 39)
Operation with the remote control is not possible. The unit does not operate correctly even when the appropriate remote control buttons are pressed.	Battery power is low. Some operations are prohibited with certain discs.	Load a new battery. Try operating with another disc.

Symptom	Cause	Action (Reference page)
Playback is not possible.	The disc is dirty. The type of disc loaded cannot be played on this unit.	Clean the disc. Check the disc type.
	The disc loaded is not compatible with this video system.	Change the disc to one that is compatible with your video system.
There is no sound. The volume level will not rise.	Cables are not connected correctly. The unit is performing still, slow motion or frame-by-frame playback.	Connect the cables correctly. There is no sound during still, slow motion or frame-by-frame playback.
There is no image displayed.	The parking brake cable is not connected. The parking brake is not applied.	Connect the parking brake cable, and apply the parking brake. Connect the parking brake cable, and apply the parking brake.
The  icon is displayed, and operation is not possible.	The operation is prohibited for the disc. The operation is not compatible with the configuration of the disc.	This operation is not possible. This operation is not possible.

Additional information

Symptom	Cause	Action (Reference page)	Symptom	Cause	Action (Reference page)
The image displayed stops (pauses) and the unit cannot be operated.	The data could no longer be read during playback.	Stop playback once, and start playback again.	Nothing is displayed. The touch panel keys cannot be used.	The rear view camera is not connected.	Connect a rear view camera.
There is no sound. The volume level is low.	The volume level is low. The attenuator is on.	Adjust the volume level. Turn the attenuator off.	No xxxx appears when a display is changed (No Title , for example).	There is no embedded text information.	Switch the display or play another track/file.
The sound and video skip.	The unit is not firmly secured. File size and transmission rate are above recommended rates.	Firmly secure the unit. Create a DivX file that is within the recommended size and transmission rate.			
The aspect ratio is incorrect and the image is stretched.	The aspect ratio setting is incorrect for the display.	Select the appropriate setting for your display. (Page 31)	Subfolders cannot be played back.	Folder repeat play has been selected.	Select the repeat range again.
The motor sounds when the ignition switch is turned ON (or is turned to ACC).	The unit is confirming whether or not a disc is loaded.	This is a normal operation.	The repeat range changes automatically.	Another folder was selected during repeat play. Track search or fast forward/reverse was performed during file repeat play.	Select the repeat range again.

Additional information

DVD

Symptom	Cause	Action (Reference page)	Symptom	Cause	Action (Reference page)
Playback is not possible.	The loaded disc has a different region number from this unit.	Replace the disc with one featuring the same region number as this unit.	Playback is not performed with the audio language and subtitle language settings selected in Video Setup menu.	The DVD being played does not feature dialog or subtitles in the selected language.	The language cannot be switched if the selected language is not recorded on the disc.
A parental lock message is displayed and playback is not possible.	Parental lock is activated.	Turn parental lock off or change the level. (Page 31)	The viewing angle cannot be switched.	The DVD being played does not feature scenes shot from multiple angles.	The viewing angle cannot be switched if the DVD does not feature scenes recorded from multiple angles.
Parental lock cannot be canceled.	The code number is incorrect. You have forgotten your code number.	Enter the correct code number. (Page 31) Press RESET . (Page 39)	You are trying to switch to multi-angle viewing for a scene that was not recorded from multiple angles.	You are trying to switch to multi-angle viewing for a scene that was not recorded from multiple angles.	Switch between multiple angles when watching scenes recorded from multiple angles.
Dialog language (and subtitle language) cannot be switched.	The DVD being played does not feature multiple language recordings. You can only switch between items indicated in the disc menu.	The language cannot be switched if they are not recorded on the disc. Switch the language using the disc menu.	No subtitles are displayed.	The DVD being played does not feature subtitles. You can only switch between items indicated in the disc menu.	Subtitles are not displayed if they are not recorded on the disc. Switch the language using the disc menu.

Additional information

Symptom	Cause	Action (Reference page)
The image is extremely unclear/distorted and dark during playback.	Some discs feature a signal to prohibit copying.	Since this unit is compatible with the analog copy generation management system, when playing a disc that has a signal prohibiting copying, horizontal stripes or other imperfections may appear when viewed on some displays. This is not a malfunction.

Video CD

Symptom	Cause	Action
The PBC (playback control) menu cannot be called up.	The Video CD being played does not feature PBC.	This operation is not available for Video CDs that do not feature PBC.
Repeat play and track/time search are not possible.	The Video CD being played features PBC.	This operation is not available for Video CDs that feature PBC.

iPod

Symptom	Cause	Action
The iPod does not operate correctly.	The cables are incorrectly connected.	Disconnect the cable from the iPod. Once the iPod's main menu is displayed, reconnect the iPod and reset it.
	The iPod version is old.	Update the iPod version.
Sound from the iPod cannot be heard.	The audio output direction may switch automatically when the Bluetooth and USB connections are used at the same time.	Use the iPod to change the audio output direction.

Additional information

Bluetooth audio/telephone

Symptom	Cause	Action
The sound from the Bluetooth audio source is not played back.	There is a call in progress on a Bluetooth connected cellular phone.	The sound will be played back when the call is terminated.
	A Bluetooth connected cellular phone is currently being operated.	Do not use the cellular phone at this time.
	A call was made with a Bluetooth connected cellular phone and then immediately terminated. As a result, communication between this unit and the cellular phone was not terminated properly.	Reconnect the Bluetooth connection between this unit and the cellular phone.

Error messages

When you contact your dealer or your nearest Pioneer Service Center, be sure to note the error message.

Common

Message	Cause	Action
AMP Error	This unit fails to operate or the speaker connection is incorrect; the protective circuit is activated.	Check the speaker connection. If the message fails to disappear even after the engine is switched off/on, contact your dealer or an authorized Pioneer Service Station for assistance.

Tuner

Message	Cause	Action
No Data Provided	This unit cannot receive artist name/song title information.	Move to the desirable location with good reception.
No Data	This unit cannot receive program service name information.	Move to the desirable location with good reception.

DVD

Message	Cause	Action (Reference page)
Different Region Disc	The disc does not have the same region number as this unit.	Replace the DVD with one bearing the correct region number.

Additional information

Message	Cause	Action (Reference page)
Error-02-XX/FF-FF	The disc is dirty.	Clean the disc.
	The disc is scratched.	Replace the disc.
	The disc is loaded upside down.	Check that the disc is loaded correctly.
	There is an electrical or mechanical error.	Press RESET . (Page 39)
Unplayable Disc	This type of disc cannot be played on this unit.	Replace the disc with one that can be played on this unit.
	The inserted disc does not contain any playable files.	Replace the disc.
Protect	All the files on the inserted disc are embedded with DRM.	Replace the disc.
Skipped	The inserted disc contains DRM protected files.	The protected files are skipped.
TEMP	The temperature of the unit is outside the normal operating range.	Wait until the unit returns to a temperature within the normal operating limits.
This DivX rental has expired.	The inserted disc contains expired DivX VOD content.	Select a file that can be played.

Message	Cause	Action (Reference page)
Video resolution not supported	The inserted disc contains a high definition DivX/MPEG-1/MPEG-2/MPEG-4 file.	Select a file that can be played.
	It is not possible to write it in the flash.	This unit's flash memory used as the temporary storage area is full. Select a file that can be played.
Your device is not authorized to play this DivX protected video.	This unit's DivX registration code has not been authorized by the DivX VOD contents provider.	Register this unit to the DivX VOD contents provider.
Unplayable File	This type of file cannot be played on this unit.	Select a file that can be played.
Format Read	Sometimes there is a delay between the start of playback and when you start to hear any sound.	Wait until the message disappears and you hear sound.
Video frame rate not supported	DivX file's frame rate is more than 30 fps.	Select a file that can be played.
Audio Format not supported	This type of file is not supported on this unit.	Select a file that can be played.

Additional information

External storage device (USB)

Message	Cause	Action
Unplayable File	This type of file cannot be played on this unit.	Select a file that can be played.
	There are no songs.	Transfer the audio files to the USB portable audio player/USB memory and connect.
	Security for the connected USB memory is enabled.	Follow the USB memory instructions to disable security.
Format Read	Sometimes there is a delay between the start of playback and when you start to hear any sound.	Wait until the message disappears and you hear sound.
Protect	All the files on the connected USB storage device are embedded with DRM.	Replace the USB storage device.
Skipped	The connected USB storage device contains DRM protected files.	The protected files are skipped.

Message	Cause	Action
Incompatible USB	The connected USB device is not supported by this unit.	Connect a USB portable audio player or USB memory that is USB Mass Storage Class compliant.
	The USB device is not formatted with FAT12, FAT16 or FAT32.	The connected USB device should be formatted with FAT12, FAT16 or FAT32.
Check USB	The USB connector or USB cable has short-circuited.	Check that the USB connector or USB cable is not caught in something or damaged.
	The connected USB storage device consumes more than maximum allowable current.	Disconnect the USB portable audio player/USB memory and do not use it. Turn the ignition switch to OFF, then to ACC or ON and then connect a compliant USB portable audio player/USB memory.

Additional information

Message	Cause	Action
Error-02-9X/-DX	Communication failed.	Perform one of the following operations. –Turn the ignition switch OFF and back ON. –Disconnect the USB portable audio player/USB memory. –Change to a different source. Then, return to the USB portable audio player/USB memory.
It is not possible to write it in the flash.	This unit's flash memory used as the temporary storage area is full.	Select a file that can be played.
Format Read	Sometimes there is a delay between the start of playback and when you start to hear any sound.	Wait until the message disappears and you hear sound.
Audio Format not supported	This type of file is not supported on this unit.	Select a file that can be played.

iPod		
Message	Cause	Action
Format Read	Sometimes there is a delay between the start of playback and when you start to hear any sound.	Wait until the message disappears and you hear sound.
Error-02-6X/-9X/-DX	Communication failed.	Disconnect the cable from the iPod. Once the iPod's main menu is displayed, reconnect the iPod and reset it.
	iPod failure.	Disconnect the cable from the iPod. Once the iPod's main menu is displayed, reconnect the iPod and reset it.
Error-02-67	The iPod firmware version is old.	Update the iPod version.
Stop	There are no songs.	Transfer songs to the iPod.
	There are no songs in the current list.	Select a list that contains songs.
Not Found	No related songs.	Transfer songs to the iPod.

Additional information

iTunes tagging		
Message	Cause	Action
iPod full. Tags not transferred.	Memory used for tag information on the iPod is full.	Sync the iPod with iTunes and clean up the tagged playlist.
Memory full. Tags not stored. Connect iPod.	This unit's flash memory used as the temporary storage area is full.	The tag information on this unit is transferred to the iPod automatically when an iPod is connected.
Tag transfer failed. Reconnect your iPod.	This unit's tag information cannot transfer to the iPod.	Check the iPod and try again.
Tag store failed.	Tag information cannot be stored in this unit.	Try again.
Error-8D	Built-in FLASH ROM encountered an error.	Turn the ignition OFF or ON.
Already stored	This tag information is already stored in memory.	Tag information can only be saved once for any given song. Tag information cannot be saved for the same song more than once.

Bluetooth		
Message	Cause	Action
Error-10	The power failed for the Bluetooth module of this unit.	Turn the ignition switch OFF and then to ACC or ON. If the error message is still displayed after performing the above action, please contact your dealer or an authorized Pioneer Service Station.
Pandora®		
Message	Cause	Action
Error-19	Communication failed.	Disconnect the cable from the iPod. Once the iPod's main menu is displayed, reconnect the iPod and reset it.
Start up the Pandora Application from your Device.	The Pandora application has not started running yet.	Start up the Pandora application from your iPhone.
Unable to save thumb rating. Try again later.	Unable to save thumb rating.	Try again later.
Unable to save Bookmark. Try again later.	Unable to save Bookmark.	Try again later.

Additional information

Message	Cause	Action
Pandora system maintenance. Try again later.	Pandora system is undergoing maintenance.	Try again later.
Skip limit reached.	Skip limit reached.	Do not exceed the skip limit.
This version of the Pandora Application is not supported.	This version of the Pandora application is not supported.	Connect an iPhone that has a compatible version of the Pandora application installed.
Check Device	Device error message displayed in the Pandora application.	Please check your iPhone.
Pandora is unable to play music. Please see your Device.	Unable to play music from Pandora.	Please check your iPhone.
Create station within the Pandora Application on Device.	No station found.	Create a station in the Pandora application on your iPhone.
No Active Station	No station selected.	Select a station.

Message	Cause	Action
Communication error occurred. Please reconnect your device.	If there is no ACK after 10 attempted retries at 750 ms, the accessory should assume that communication is interrupted and disconnect from PandoraLink.	Please reconnect your iPhone and try again.
Device has not been registered. Go to Bluetooth Connection Menu to register.	No Bluetooth device found.	Follow the instructions that appear on the screen.
BT Error. Press BAND key to retry.	Bluetooth connection failed.	Follow the instructions that appear on the screen.
Start up Pandora. Press BAND key to retry.	Connection to the Pandora application failed.	Follow the instructions that appear on the screen.
Check Pandora. Press BAND key to retry.	Connection to the Pandora application failed.	Follow the instructions that appear on the screen.
Disconnected. Press BAND key to retry.	Bluetooth connection lost.	Follow the instructions that appear on the screen.

Additional information

Understanding auto EQ error messages

When correct measurement of the car's interior acoustic characteristics is not possible using auto EQ, an error message may appear on the display. In such cases, refer to the table below to see what the problem is and how it may be corrected. After checking, try again.

Message	Cause	Action
Please connect the microphone for measurement. When finished, please push HOME key.	The microphone is not connected.	Plug the optional microphone securely into the jack.
Error. Please check xxxx speaker.	The microphone cannot pick up the measuring tone of a speaker.	<ul style="list-style-type: none"> • Confirm that the speakers are connected correctly. • Correct the input level setting of the power amp connected to the speakers. • Plug the microphone securely into the jack.
Error. Please check noise.	The surrounding noise level is too high.	<ul style="list-style-type: none"> • Stop your car in a place that is quiet, and switch off the engine, air conditioner and heater. • Set the microphone correctly.

Message	Cause	Action
Error. Please check battery.	Power is not being supplied from the battery to this unit.	<ul style="list-style-type: none"> • Connect the battery correctly. • Check the battery voltage.

Understanding messages

Messages	Translation
Screen image may appear reversed.	Pioneer recommends the use of a camera which outputs mirror-reversed images. Otherwise, the screen image will appear reversed.

Additional information

Indicator list

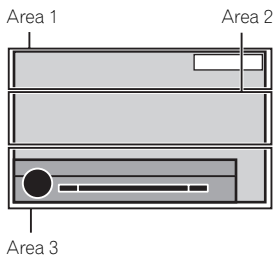

Area 1

	Indicates that the volume is adjusted.
	Indicates that the mute function is on.
	Indicates that the sound is attenuated.

Area 2

	Shows when downloadable song information (tag) from a radio station is received.
	Indicates that the digital format is Dolby Digital.
	Indicates that the digital format is MPEG Audio.

	Indicates that the digital format is Linear PCM.
	Indicates the sampling frequency.
	Indicates that the digital format is DTS.
	Indicates the audio channel.
	Indicates that a disc with PBC On is being played.
	<ul style="list-style-type: none"> Indicates that a cellular phone is connected. Indicates that an incoming call has been received and has not been checked yet.
	Indicates the battery strength of the cellular phone. <ul style="list-style-type: none"> The level shown on the indicator may differ from the actual battery strength. If the battery strength is not available, nothing is displayed in the battery strength indicator area.
	Indicates that the connected Bluetooth device only supports Bluetooth telephone.

Additional information

	Indicates that the connected Bluetooth device only supports Bluetooth audio.
	Show the album title when receiving the tag information. Shows the album title of the song currently being played for MP3/WMA/AAC/WAV files.
	Shows the song title when receiving the tag information. Shows the song title of the song currently being played for MP3/WMA/AAC/WAV files.
	Shows the comment currently being played.
	Shows the station name currently tuned in to.
	Shows the artist name when receiving the tag information. Shows the artist name of the artist currently being played for MP3/WMA/AAC/WAV files.
	Shows cellular phone information.
	Shows general phone information.
	Shows home phone information.
	Shows office phone information.
	Shows other phone information.
	Shows the composer name.
	Shows the folder name of the folder containing the MP3/WMA/AAC/WAV file currently being played.
	Shows the file name of the MP3/WMA/AAC/WAV file currently being played.
	Shows the preset number of the station currently being tuned in to.
	Shows the channel currently being tuned in to.
	Shows the title number currently being played.
	Shows the chapter number currently being played.
	Shows the replay time currently being played.
	Shows the genre of the track/song currently being played.

Area 3

	Shows when radio signal is received.
	Touch to turn BSM on.
	Indicates that Auto EQ is on.

Additional information



Shows when this unit has the song information (tag).



Indicates that the unit is currently processing an operation such as search.



Shows when creating the database in Music browse mode.



Shows when saving the database in Music browse mode.



Indicates the signal strength of the cellular phone.



Indicates that a Bluetooth telephone is connected.

Handling guidelines

Discs and player

Use discs featuring any of the following logos.



Use 12-cm discs. Do not use 8-cm discs or an adapter for 8-cm discs.

Use only conventional, fully circular discs. Do not use shaped discs.



Do not insert anything other than a DVD-R/RW or CD-R/RW into the disc loading slot.

Do not use cracked, chipped, warped, or otherwise damaged discs as they may damage the player.

Unfinalized CD-R/RW discs cannot be played back.

Do not touch the recorded surface of the discs.

Store discs in their cases when not in use.

Do not attach labels, write on or apply chemicals to the surface of the discs.

To clean a disc, wipe the disc with a soft cloth outward from the center.

Additional information

Condensation may temporarily impair the player's performance. Let it rest for about one hour to adjust to a warmer temperature. Also, wipe any damp discs off with a soft cloth.

Playback of discs may not be possible because of disc characteristics, disc format, recorded application, playback environment, storage conditions, and so on.

Road shocks may interrupt disc playback.

Certain functions may not be available for some DVD video discs.

It may not be possible to play back some DVD video discs.

It is not possible to play back DVD-RAM discs.

This unit is not compatible with discs recorded in AVCHD (Advanced Video Codec High Definition) format. Do not insert AVCHD discs as you may not be able to eject the disc.

When using discs that can be printed on label surfaces, check the instructions and the warnings of the discs. Depending on the discs, inserting and ejecting may not be possible. Using such discs may result in damage to this equipment.

Do not attach commercially available labels or other materials to the discs.

- The discs may warp making the disc unplayable.
- The labels may come off during playback and prevent ejection of the discs, which may result in damage to the equipment.

External storage device (USB)

Depending on the external storage device (USB), the following problems may occur.

- Operations may vary.
- The storage device may not be recognized.
- Files may not be played back properly.

USB storage device

Connections via USB hub are not supported.

Do not connect anything other than a USB storage device.

Firmly secure the USB storage device when driving. Do not let the USB storage device fall onto the floor, where it may become jammed under the brake or accelerator pedal.

Depending on the USB storage device, the device may cause noise to occur in the radio.

Copyright protected files that are stored in the USB devices cannot be played back.

You cannot connect a USB portable audio player/USB memory to this unit via USB hub.

Partitioned USB memory is not compatible with this unit.

Depending on the kind of USB portable audio player/USB memory you use, the device may not be recognized or audio files may not be played back properly.

Do not leave the USB portable audio player/USB memory in direct sunlight for extended amounts of time. Doing so may cause the device to malfunction from the extreme rise in temperature.

iPod

To ensure proper operation, connect the dock connector cable from the iPod directly to this unit.

Firmly secure the iPod when driving. Do not let the iPod fall onto the floor, where it may become jammed under the brake or accelerator pedal.

Additional information

About iPod settings

- When an iPod is connected, this unit changes the EQ (equalizer) setting of the iPod to off in order to optimize the acoustics. When you disconnect the iPod, the EQ returns to the original setting.
- You cannot set Repeat to off on the iPod when using this unit. Repeat is automatically changed to All when the iPod is connected to this unit.

Incompatible text saved on the iPod will not be displayed by the unit.

DVD-R/RW discs

Unfinalized DVD-R/RW discs which have been recorded in the Video format (video mode) cannot be played back.

Playback of DVD-R/RW discs may not be possible, due to disc characteristics, scratches or dirt on the disc, or dirt, condensation, etc. on the lens of this unit.

Depending on the application settings and the environment, playback of discs recorded on a computer may not be possible. (For details, contact the manufacturer of the application.)

CD-R/RW discs

When CD-R/RW discs are used, playback is possible only for discs which have been finalized.

Playback of CD-R/RW discs recorded on a music CD recorder or a computer may not be possible due to disc characteristics, scratches or dirt on the disc, or dirt, condensation, etc., on the lens of this unit.

Depending on the application settings and the environment, playback of discs recorded on a computer may not be possible. (For details, contact the manufacturer of the application.)

Playback of CD-R/RW discs may become impossible in case of direct exposure to sunlight, high temperatures, or the storage conditions in the vehicle.

Titles and other text information recorded on a CD-R/RW disc may not be displayed by this unit (in the case of audio data (CD-DA)).

DualDiscs

DualDiscs are two-sided discs that have a recordable CD for audio on one side and a recordable DVD for video on the other.

Playback of the DVD side is possible with this unit. However, since the CD side of DualDiscs is not physically compatible with the general CD standard, it may not be possible to play the CD side with this unit.

Frequent loading and ejecting of a DualDisc may result in scratches on the disc. Serious scratches can lead to playback problems on this unit. In some cases, a DualDisc may become stuck in the disc loading slot and will not eject. To prevent this, we recommend you refrain from using DualDisc with this unit.

Please refer to the information from the disc manufacturer for more detailed information about DualDiscs.

DivX video files

Depending on the composition of the file information, such as the number of audio streams or file size, there may be a slight delay when playing back discs.

Some special operations may be prohibited due to the composition of the DivX files.

Only DivX files downloaded from a DivX partner site are guarantee for proper operation. Unauthorized DivX files may not operate properly.

Additional information

DRM rental files cannot be operated until playback is started.

Recommended file size: 2 GB or less with a transmission rate of 2 Mbps or less.

The ID code of this unit must be registered to a DivX VOD provider in order to playback DivX VOD files. For information on ID codes, refer to *Displaying the DivX® VOD registration code* on page 32.

MPEG-1/MPEG-2/MPEG-4 video files

Elapsed playback time may not be displayed correctly.

Audio compatibility (USB)

WAV

File extension: .wav

Quantization bits: 8 and 16 (LPCM), 4 (MS ADPCM)

Sampling frequency: 16 kHz to 48 kHz (LPCM), 22.05 kHz and 44.1 kHz (MS ADPCM)

Compressed audio compatibility (disc, USB)

WMA

File extension: .wma

Bit rate: 48 kbps to 320 kbps (CBR), VBR

Sampling frequency: 32 kHz to 48 kHz

Windows Media™ Audio Professional, Lossless, Voice/DRM Stream/Stream with video: Not compatible

MP3

File extension: .mp3

Bit rate: 8 kbps to 320 kbps (CBR), VBR

Sampling frequency: 8 kHz to 48 kHz (32 kHz, 44.1 kHz, 48 kHz for emphasis)

Compatible ID3 tag version: 1.0, 1.1, 2.2, 2.3, 2.4 (ID3 tag Version 2.x is given priority over Version 1.x.)

M3u playlist: Not compatible

MP3i (MP3 interactive), mp3 PRO: Not compatible

AAC

Compatible format: AAC encoded by iTunes

File extension: .m4a

Sampling frequency: 11.025 kHz to 48 kHz

Bit rate: 16 kbps to 320 kbps

Apple Lossless: Not compatible

AAC file bought from the iTunes Store (.m4p file extension): Not compatible

DivX compatibility (disc)

Compatible format: DivX video format implemented in relation to DivX standards

File extensions: .avi or .divx

DivX Ultra format: Not compatible

DivX HD format: Not compatible

Additional information

DivX files without video data: Not compatible

DivX plus: Not compatible

Compatible audio codec: MP2, MP3, Dolby Digital

LPCM: Compatible

Bit rate: 8 kbps to 320 kbps (CBR), VBR

Sampling frequency: 8 kHz to 48 kHz

Compatible external subtitle file extension: .srt

MPEG-1/MPEG-2/MPEG-4 video (disc)

File extensions: .mpg or .mpeg (MPEG-1/MPEG-2), .avi (MPEG-4)

Compatible audio codec: MP2 (MPEG-1/MPEG-2), MP2, MP3, Dolby Digital (MPEG-4)

H.264 (MPEG-4AVC): Compatible

LPCM: Not compatible

Bit rate: 8 kbps to 320 kbps (CBR), VBR

Sampling frequency: 8 kHz to 48 kHz

Supplemental information

Some characters in a file name (including the file extension) or a folder name may not be displayed.

This unit may not work properly depending on the application used to encode WMA files.

There may be a slight delay at the start of playback of audio files embedded with image data or audio files stored on a USB storage device that has numerous folder hierarchies.

Disc (CD/DVD)

Playable folders: up to 99 for CD-R/RW

Playable folders: up to 700 for DVD-R/RW

Playable files: up to 999 for CD-R/RW

Playable files: up to 3500 for DVD-R/RW

File system: ISO 9660 Level 1 and 2, Romeo, Joliet, UDF 1.02 (DVD-R/RW)

Multi-session playback: Compatible

Packet write data transfer: Not compatible

Regardless of the length of blank sections between the songs from the original recording, compressed audio discs play with a short pause between songs.

External storage device (USB)

Playable folders: up to 1500

Playable files: up to 15000

Playback of copyright-protected files: Not compatible

Partitioned external storage device (USB): Only the first playable partition can be played.

There is no compatibility for Multi Media Cards (MMC).

CAUTION

- Pioneer accepts no responsibility for data lost on the USB memory/USB portable audio player even if that data is lost while using this unit.
- Pioneer cannot guarantee compatibility with all USB mass storage devices and assumes no responsibility for any loss of data on media players, smart phones, or other devices while using this product.

Additional information

- Do not leave the discs/external storage device (USB) or iPod in places with high temperatures.

iPod compatibility

This unit supports only the following iPod models. Supported iPod software versions are shown below. Older versions may not be supported.

Made for

- iPod touch 5th generation (software version 6.0.1)
- iPod touch 4th generation (software version 5.1.1)
- iPod touch 3rd generation (software version 5.1.1)
- iPod touch 2nd generation (software version 4.2.1)
- iPod touch 1st generation (software version 3.1.3)
- iPod classic 160GB (software version 2.0.4)
- iPod classic 120GB (software version 2.0.1)
- iPod classic (software version 1.1.2)
- iPod with video (software version 1.3)
- iPod nano 7th generation (software version 1.0.1)
- iPod nano 6th generation (software version 1.2)
- iPod nano 5th generation (software version 1.0.2)
- iPod nano 4th generation (software version 1.0.4)
- iPod nano 3rd generation (software version 1.1.3)
- iPod nano 2nd generation (software version 1.1.3)
- iPod nano 1st generation (software version 1.3.1)
- iPhone 5 (software version 6.0.1)
- iPhone 4S (software version 5.1.1)
- iPhone 4 (software version 5.1.1)
- iPhone 3GS (software version 5.1.1)
- iPhone 3G (software version 4.2.1)

- iPhone (software version 3.1.3)

Depending on the generation or version of the iPod, some functions may not be available.

Operations may vary depending on the software version of iPod.

About the file/format compatibility, refer to the iPod manuals.

Audiobook, Podcast: Compatible

CAUTION

Pioneer accepts no responsibility for data lost on the iPod, even if that data is lost while this unit is used.

About iTunes tagging

This function can be performed with the following iPod models.

- iPod touch 4th generation
- iPod touch 3rd generation
- iPod touch 2nd generation
- iPod touch 1st generation
- iPod classic 160GB
- iPod classic 120GB
- iPod classic
- iPod with video
- iPod nano 6th generation
- iPod nano 5th generation
- iPod nano 4th generation
- iPod nano 3rd generation
- iPhone 4S
- iPhone 4
- iPhone 3GS
- iPhone 3G
- iPhone

Additional information

The song information (tag) can be saved from the broadcasting station to your iPod. The songs will show up in a playlist called "Tagged playlist" in iTunes the next time you sync your iPod. Then you can directly buy the songs you want from the iTunes Store.

The tagged songs and the song that you can buy from the iTunes Store may be different. Make sure to confirm the song before you make the purchase.

If you cannot use this function normally, update your iPod firmware.

Sequence of audio files

The user cannot assign folder numbers and specify playback sequences with this unit.

Example of a hierarchy

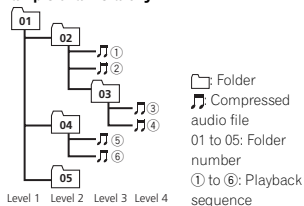

Disc

Folder selection sequence or other operation may differ depending on the encoding or writing software.

External storage device (USB)

The playback sequence is the same as the recorded sequence in the external storage device (USB).

To specify the playback sequence, the following method is recommended.

- ① Create a file name that includes numbers that specify the playback sequence (e.g., 001xxx.mp3 and 0099yyy.mp3).
- ② Put those files into a folder.
- ③ Save the folder that contains the files to the external storage device (USB).

However, depending on the system environment, you may not be able to specify the playback sequence.

For USB portable audio players, the sequence is different and depends on the player.

Using the display correctly

⚠ CAUTION

- If liquid or foreign matter should get inside this unit, turn off the power immediately and consult your dealer or the nearest authorized PIONEER Service Station. Do not use the unit in this condition because doing so may result in fire, electric shock, or other failure.
- If you notice smoke, a strange noise or smell, or any other abnormal signs from the display, turn off the power immediately and consult your dealer or the nearest authorized PIONEER Service Station. Using this unit in this condition may result in permanent damage to the system.
- Do not disassemble or modify this unit, as there are high-voltage components inside which may cause electric shock. Be sure to consult your dealer or the nearest authorized PIONEER Service Station for internal inspection, adjustments, or repairs.

Handling the display

- Never touch the screen with anything besides your finger when operating the touch panel function. The screen can scratch easily.

Additional information

- When the display is subjected to direct sunlight for a long period of time, it will become very hot resulting in possible damage to the LCD screen. You should avoid exposing the display unit to direct sunlight as much as possible.
- The display should be used within the temperature range of 14°F to 140°F. At temperatures higher or lower than this operating temperature range, the display may not operate normally.
- The LCD screen is exposed in order to increase its visibility within the vehicle. Do not press it strongly on it as this may damage it.
- Do not push the LCD screen forcefully as this may scratch it.
- The product lifetime of the LED backlight is more than 10 000 hours. However, it may decrease if used in high temperatures.
- If the LED backlight reaches the end of its product lifetime, the screen will become dark and the image will no longer be projected. In such cases, please consult your dealer or the nearest authorized PIONEER Service Station.

Keeping the display in good condition

- When removing dust from the screen or cleaning the display, first turn the system power off, then wipe with a soft dry cloth.
- When wiping the screen, take care not to scratch the surface. Do not use harsh or abrasive chemical cleaners.

Liquid crystal display (LCD) screen

- Heat from the heater may damage the LCD screen, and cool air from the cooler may cause moisture to form inside the display resulting in possible damage.
- Small black dots or white dots (bright dots) may appear on the LCD screen. These are due to the characteristics of the LCD screen and do not indicate a malfunction.
- When using a cellular phone, keep the antenna away from the display to prevent disruption of the video image by the appearance of spots, colored stripes, etc.

LED (light-emitting diode) backlight

- At low temperatures, using the LED backlight may increase image lag and degrade the image quality due to the characteristics of the LCD screen. Image quality will improve with an increase in temperature.
- To protect the LED backlight, the display will darken in the following environments:
 - In the direct sunlight
 - Near the heater vent

Bluetooth profiles

In order to use Bluetooth wireless technology, devices must be able to interpret certain profiles. This unit is compatible with the following profiles.

- GAP (Generic Access Profile)
- SDP (Service Discovery Protocol)
- OPP (Object Push Profile)
- HFP (Hands Free Profile)
- HSP (Head Set Profile)
- PBAP (Phone Book Access Profile)
- A2DP (Advanced Audio Distribution Profile)
- AVRCP (Audio/Video Remote Control Profile) 1.3
- SPP (Serial Port Profile) 1.1

Additional information

License, Warranty Disclaimer & Limitation of Liability

This item incorporates copy protection technology that is protected by U.S. patents and other intellectual property rights of Rovi Corporation. Reverse engineering and disassembly are prohibited.

Disclaimer

THE WARRANTIES SET FORTH IN PIONEER'S LIMITED WARRANTY ARE THE ONLY WARRANTIES MADE BY PIONEER OR ANY OF ITS LICENSORS, AS APPLICABLE. PIONEER AND ITS LICENSORS EXPRESSLY DISCLAIM ALL OTHER WARRANTIES, EXPRESS OR IMPLIED, INCLUDING, WITHOUT LIMITATION, WARRANTIES OF MERCHANTABILITY AND FITNESS FOR A PARTICULAR PURPOSE.

Limitation of Liability

TO THE MAXIMUM EXTENT PERMISSIBLE UNDER APPLICABLE LAW, NEITHER PIONEER NOR ITS LICENSORS WILL BE LIABLE TO YOU OR TO ANY OTHER PARTY FOR ANY INDIRECT, CONSEQUENTIAL, INCIDENTAL, PUNITIVE, OR SPECIAL DAMAGES, REGARDLESS OF THE FORM OF ACTION, WHETHER IN CONTRACT OR IN TORT, INCLUDING NEGLIGENCE, EVEN IF SUCH PARTIES HAVE BEEN ADVISED OF THE POSSIBILITY OF SUCH DAMAGES.

TO THE MAXIMUM EXTENT PERMISSIBLE UNDER APPLICABLE LAW, PIONEER'S, OR ITS LICENSORS', TOTAL LIABILITY OF ANY KIND ARISING OUT OF OR RELATED TO YOUR USE OF THE PRODUCTS, INCLUDING, BUT NOT LIMITED TO, ANY WARRANTY CLAIMS, OR ANY CLAIMS FOR PROPERTY DAMAGE, DEATH OR DISABILITY, REGARDLESS OF THE FORUM

AND REGARDLESS OF WHETHER ANY ACTION OR CLAIM IS BASED ON CONTRACT, TORT, (INCLUDING NEGLIGENCE), STRICT PRODUCT LIABILITY, OR ANY OTHER LEGAL THEORY, WILL NOT EXCEED ONE THOUSAND DOLLARS. SOME JURISDICTIONS DO NOT ALLOW THE EXCLUSION OF DAMAGES OR LIMITATION OF LIABILITY, SO THE ABOVE EXCLUSIONS OR LIMITATIONS, TO THE EXTENT PROHIBITED BY APPLICABLE LAW, MAY NOT APPLY TO YOU. YOUR SPECIFIC RIGHTS MAY VARY FROM JURISDICTION TO JURISDICTION.

Bluetooth

The *Bluetooth*® word mark and logos are registered trademarks owned by Bluetooth SIG, Inc. and any use of such marks by PIONEER CORPORATION is under license. Other trademarks and trade names are those of their respective owners.

DVD video

DVD is a trademark of DVD Format/Logo Licensing Corporation.

iTunes

Apple and iTunes are trademarks of Apple Inc., registered in the U.S. and other countries.

MP3

Supply of this product only conveys a license for private, non-commercial use and does not convey a license nor imply any right to use this product in any commercial (i.e. revenue-generating) real time broadcasting (terrestrial, satellite, cable and/or any other media), broadcasting/streaming via internet, intranets and/or other networks or in other electronic content distribution systems, such as pay-audio or audio-on-demand applications. An independent license for such use is required.

Additional information

WMA

Windows Media is either a registered trademark or trademark of Microsoft Corporation in the United States and/or other countries. This product includes technology owned by Microsoft Corporation and cannot be used or distributed without a license from Microsoft Licensing, Inc.

iPod & iPhone

iPhone, iPod, iPod classic, iPod nano, and iPod touch are trademarks of Apple Inc., registered in the U.S. and other countries. Lightning is a trademark of Apple Inc. "Made for iPod" and "Made for iPhone" mean that an electronic accessory has been designed to connect specifically to iPod or iPhone, respectively, and has been certified by the developer to meet Apple performance standards. Apple is not responsible for the operation of this device or its compliance with safety and regulatory standards. Please note that the use of this accessory with iPod or iPhone may affect wireless performance.

Android™ & Google Play

Android and Google Play are trademarks of Google Inc.

Dolby Digital

Manufactured under license from Dolby Laboratories. Dolby and the double-D symbol are trademarks of Dolby Laboratories.

DivX

DivX®, DivX Certified® and associated logos are trademarks of Rovi Corporation or its subsidiaries and are used under license.

ABOUT DIVX VIDEO: DivX® is a digital video format created by DivX, LLC, a subsidiary of Rovi Corporation. This is an official DivX Certified® device that plays DivX video. Visit divx.com for more information and software tools to convert your files into DivX videos.

ABOUT DIVX VIDEO-ON-DEMAND: This DivX Certified® device must be registered in order to play purchased DivX Video-on-Demand (VOD) movies. To obtain your registration code, locate the DivX VOD section in *Displaying the DivX® VOD registration code*. Go to vod.divx.com for more information on how to complete your registration.

Pandora® internet radio

PANDORA, the PANDORA logo, and the Pandora trade dress are trademarks or registered trademarks of Pandora Media, Inc. Used with permission.

MIXTRAX

MIXTRAX is a trademark of the PIONEER CORPORATION.

libpng

Please be aware in advance that Pioneer will not respond to questions concerning the contents of the source code. This licence was originally written in English and translated here only to help the reader understand its content. Therefore, please note that translated licence is NOT legally identified with the original English text. This copy of the libpng notices is provided for your convenience. In case of any discrepancy between this copy and the notices in the file `png.h` that is included in the libpng distribution, the latter shall prevail. COPYRIGHT NOTICE, DISCLAIMER, and LICENSE: If you modify libpng you may insert additional notices immediately following this sentence.