

- STEP 1:** Inspect Cargo Carrier for any missing straps or damages. Straps must be free from tears and buckles must be free from cracks.
- STEP 2:** Unfold Cargo Carrier with bottom side (soft grey side) facing upward.
- STEP 3:** Determine what type of roof rack your vehicle has. From the top of the vehicle match to the images in Fig. 1.

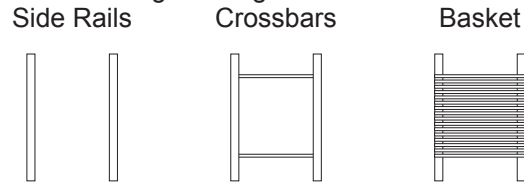

Fig. 1

NOTE: Some vehicles come with both crossbars and side rails where the cross bars can be adjusted inward or outward. It is recommended that the bars be moved to their outermost position and then locked into places. See Fig. 2.

STEP 4: Strap Placement

Side Rail Placement

Crossbars/Basket Placement

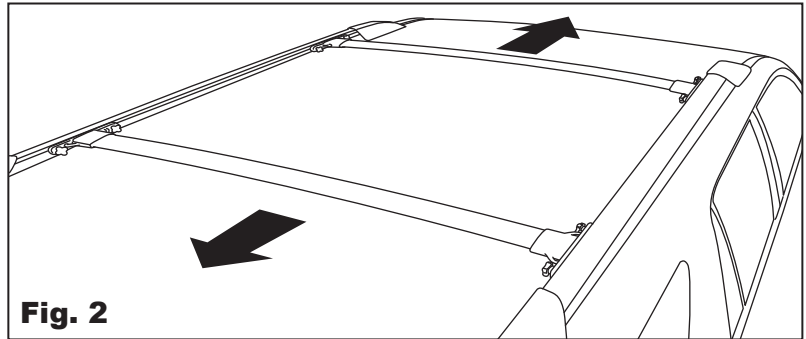
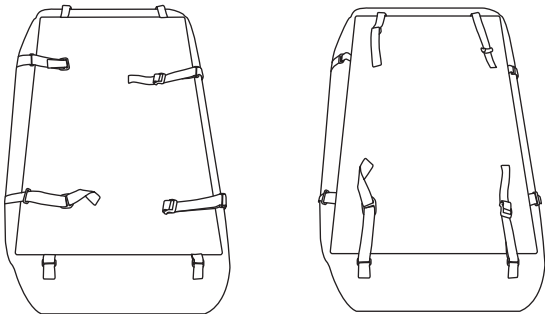
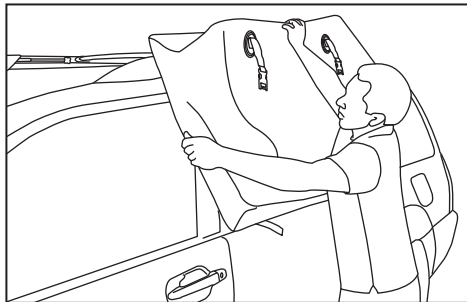

Fig. 2

STEP 5: Once straps are in their proper position, turn the cargo carrier over so that the bottom of the carrier is resting on the ground. Position the front of the cargo carrier in the same forward direction as the vehicle, then carefully place the cargo carrier onto top of the vehicle. Make sure that the cargo carrier is placed in the center of the side rails and cross bars. Do not place the cargo carrier on top of the crossbars or rails.



STEP 6: Securing strap to vehicle:

- 1) Run one end of strap under the rail and back to the buckle.
- 2) See Fig.3 for attaching strap to buckle.
- 3) Tighten straps equally on all four sides.

Fig. 3

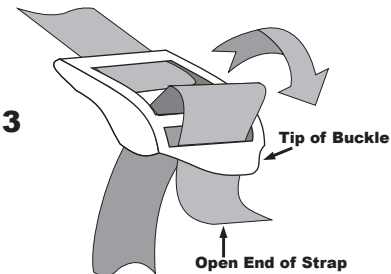

CAUTION! Do not pull the strap to the point where the buckle may break.

STEP 7: Once all four straps have been secured, open the pack and you can now proceed to load your items.

WARNING! Do not exceed the weight limit of your vehicle's roof. Read owners manual to find maximum weight limit.

STEP 8: Once packing is complete, zip pack closed and connect compression strap buckles. Make sure that all four buckles are pulled tightly enough to where top of the bag is void of space.

CAUTION! Do not pull the strap to the point where the buckle may break.

STEP 9: Once all buckles have been secured check the cargo carrier by moving it forward and back and side to side.

- If cargo carrier is able to move on the rails then tighten the straps from the pack to the rail.
- If items in cargo carrier are moving excessively, tighten the strap buckles until movement has minimized.