

**Bike Rack Description:**

Holds 2 bikes

Pivot design allows easy access to rear door and lid of vehicle

**Section 1 - Bike Rack Assembly:**

STEP 1: Insert spacer into rack bar.

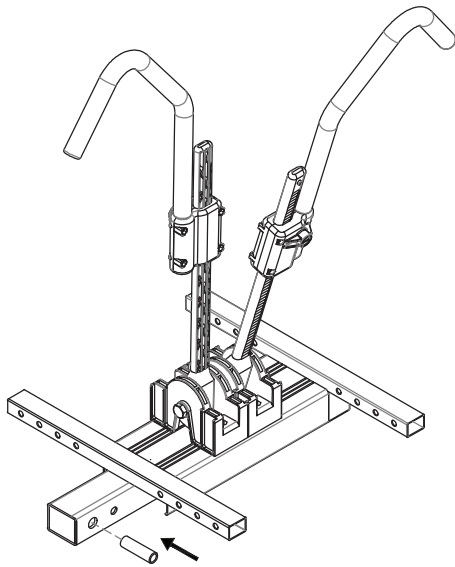

Step 2: Attach hitch to rack bar. Align hole on the front of the rack with hole inside of the U-joint.

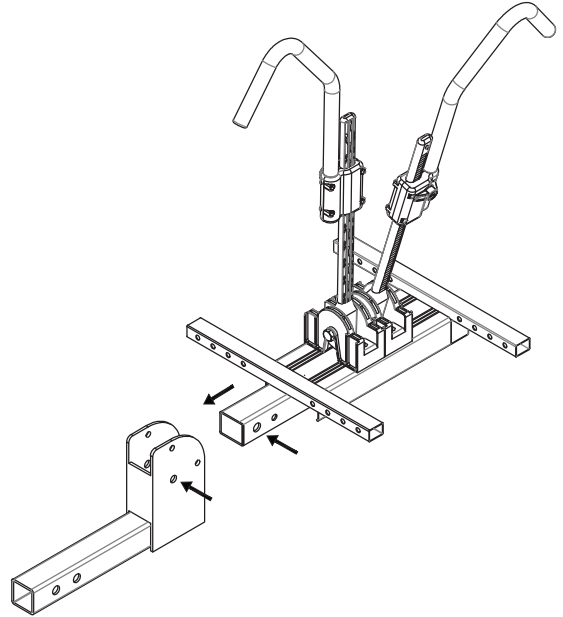

STEP 3: Insert bolt through hole in the U-joint hitch and out the other end.

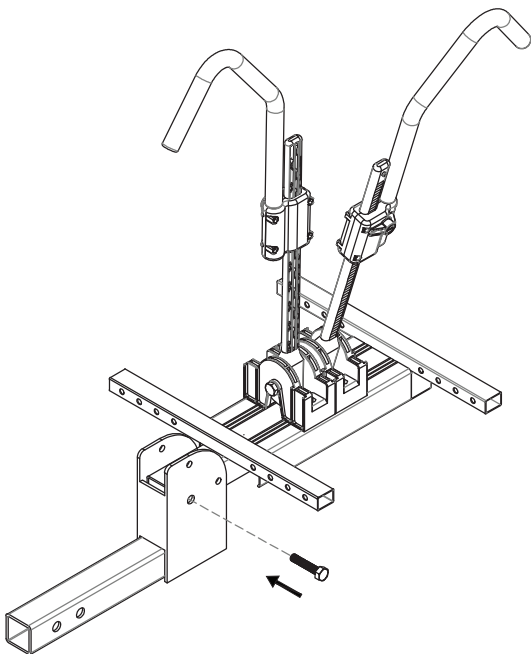

STEP 4: Attach lock nut to the bolt and secure tight enough where the rack bar is able to pivot.

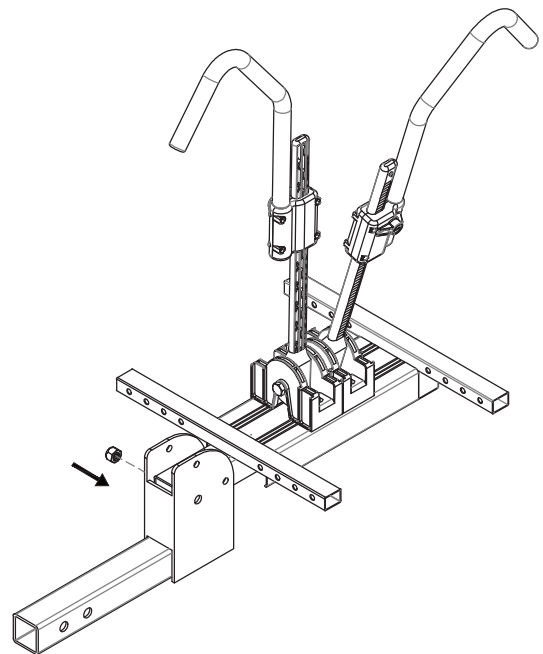

STEP 5: Insert locking pin through hole of U-joint and secure in place with latch.

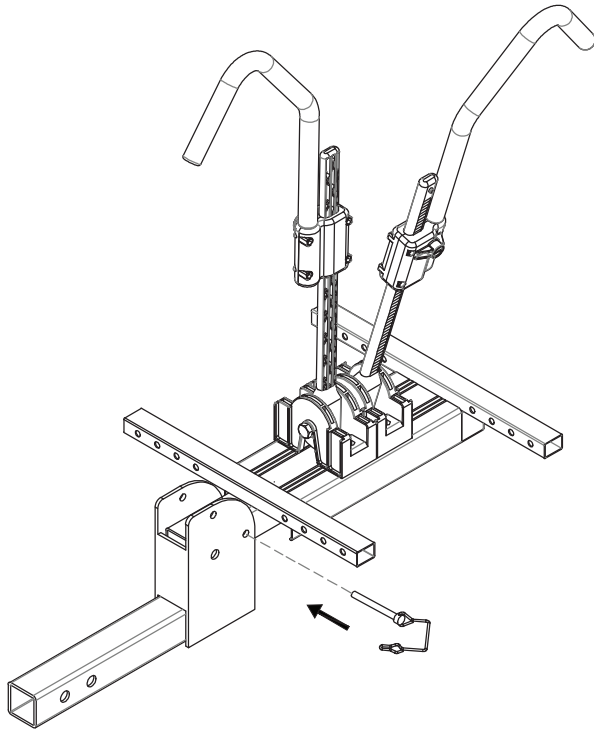

STEP 6: Press pin firmly and slide assembly into the rack.

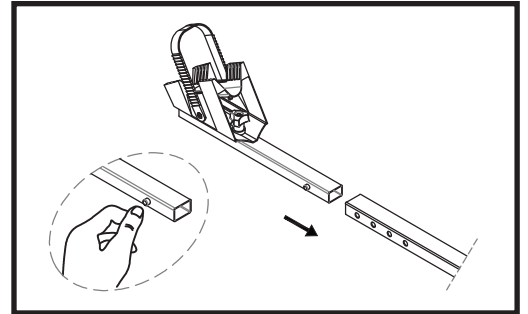
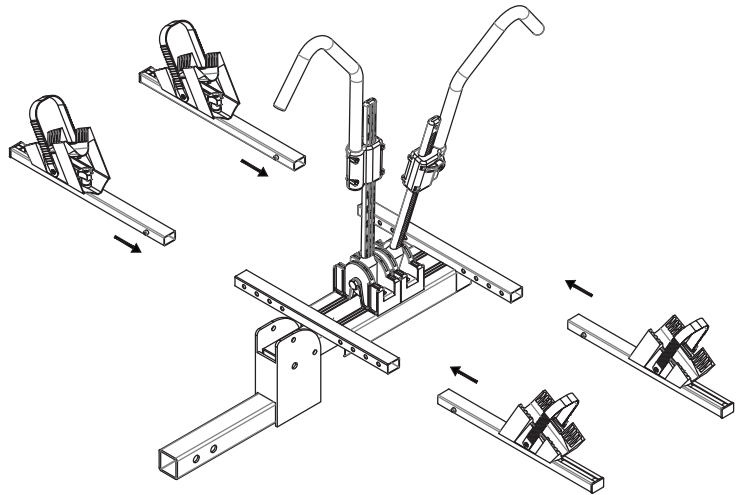

### Section 2 - Bike Mounting:

STEP 1: Adjust the brackets so that the wheels rest properly in the slots.

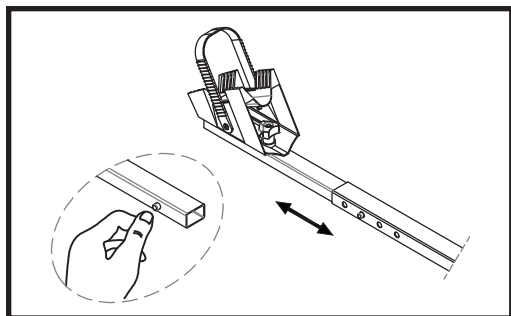
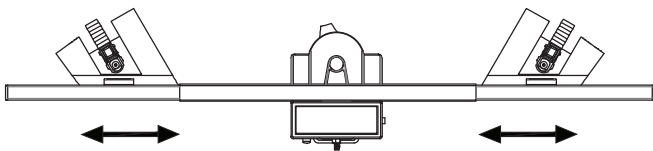

STEP 2: Unlock the arm to move clear of the bike frame.

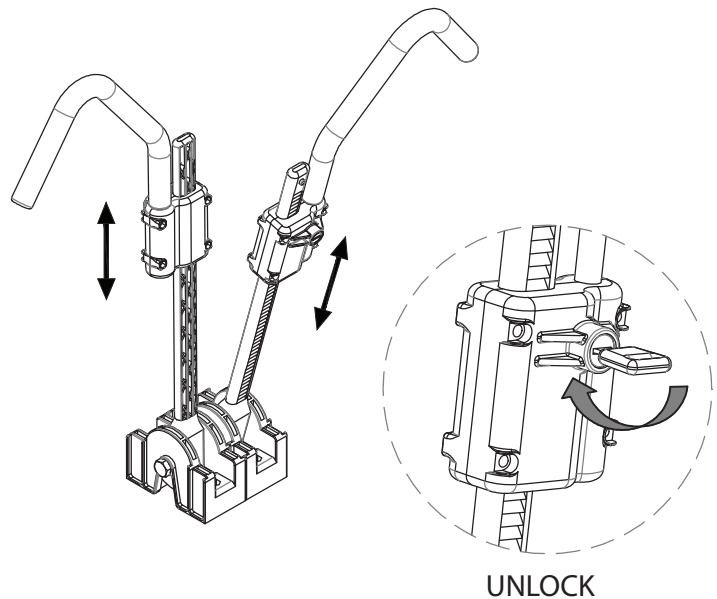

STEP 1: Place bike on top of bike rack with the wheels resting properly in the slots.

STEP 2: Bring the arm down on top of the bike frame and lock it in place by turning the key counter clockwise.

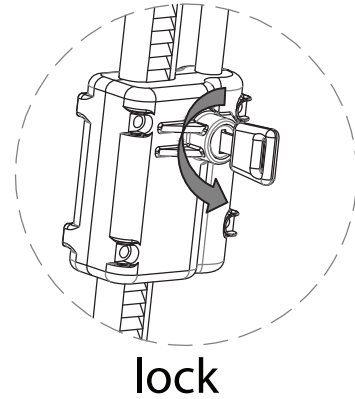
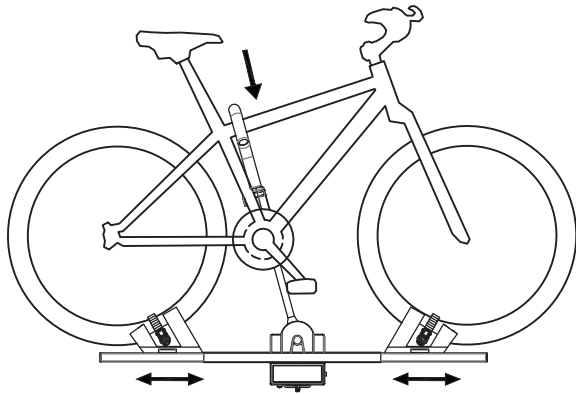

STEP 3: Put strap over wheel. Press down on lever and pull strap through the slot below it.

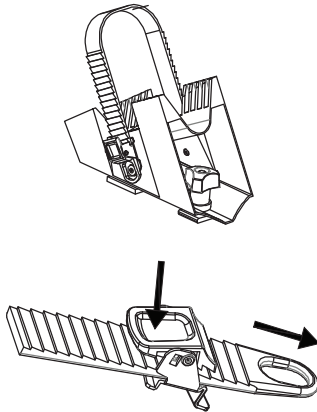

This completes rack mounting.

STEP 4: Safety Inspection - With both hands, shake the bike up, down, left and right to confirm bike and rack are secure.

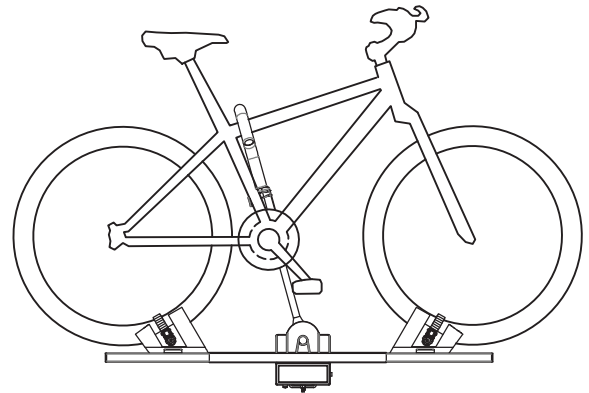

This completes safety inspection.

### Section 3 - Open Rear Door of Vehicle:

STEP 1: With no bikes on the bike rack, remove locking pin.

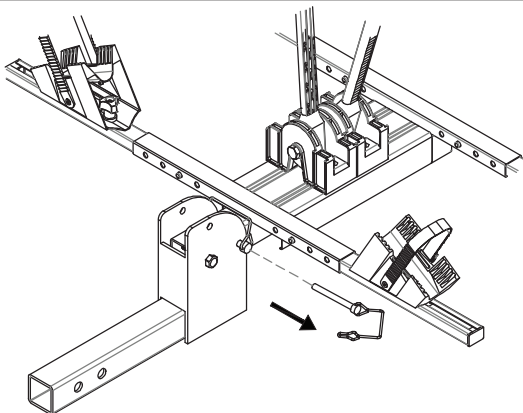

STEP 2: Tilt the bike rack towards the floor.

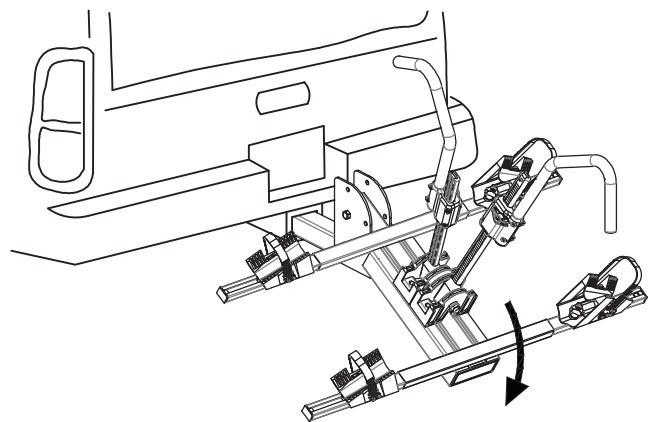

**Section 4 - When Rack is Not in Use:**

STEP 1: Fold the arms down.

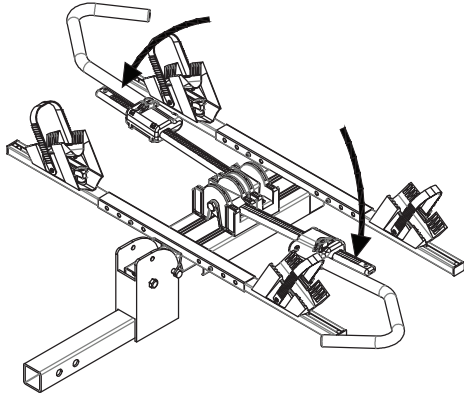

STEP 2: Remove locking pin.

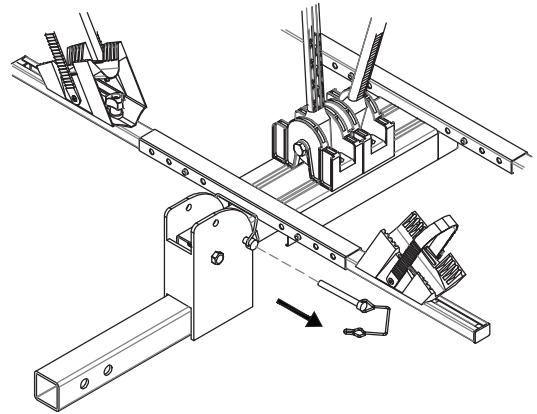

STEP 3: Place bike rack in the upright position.

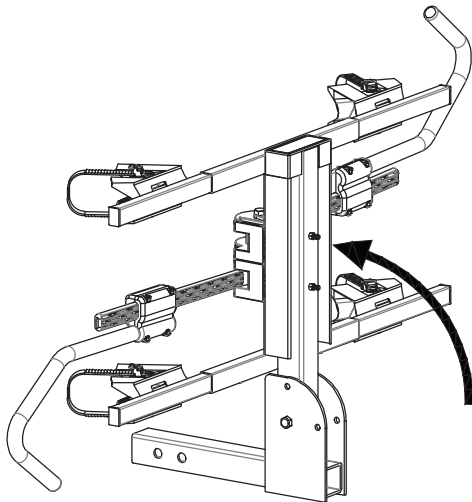

STEP 4: Insert locking pin into the top hole of the U-joint.

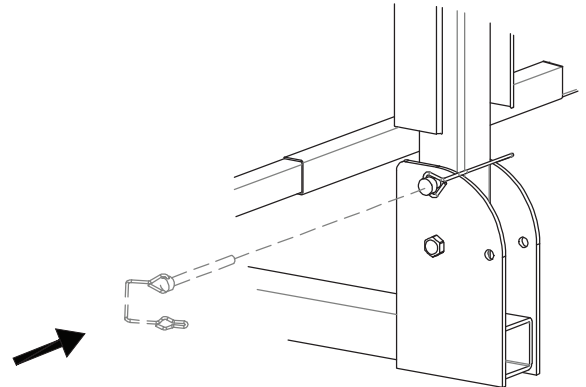

STEP 5: Place strap around the arms and tighten it.

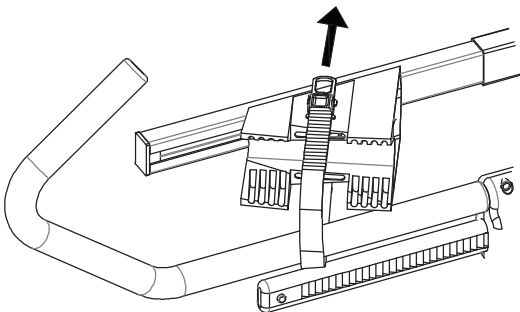

STEP 6: Confirm all the parts are secure.

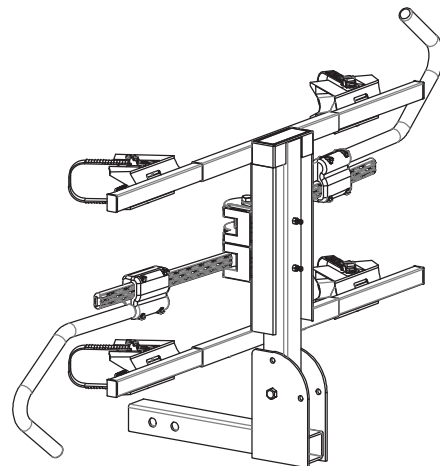



### Disclaimer

When using Bully Load carriers and accessories, the user must understand the precautions. The points listed below will assist you in using the rack system and will encourage safety.

- For quality fits and safety, use only the recommended rack or accessory.
- Unless stated otherwise in these instructions, do not carry more than 59 kg (130 lbs.) on Bully load carriers. Bully cannot warranty loads that exceed this limit.  
Total load = cargo weight plus weight of accessories used to carry cargo.
- Check local and state laws governing projection of objects beyond the perimeter of a vehicle. Be aware of the width and height of your cargo since low clearance can affect the load. All cargo will affect the vehicle's driving behavior. Never drive with any lock, knob or rack in an open or unlocked position.
- All locks must be turned and moved periodically to ensure smooth operation. Remove valuable gear if your vehicle is unattended for an extended period. Place at least one key in the glove compartment.
- For safety to your vehicle and rack system, obey all posted speed limits and traffic cautions. Adapt your speed to the conditions of the road and the load being carried.
- Do not use Bully load carriers and accessories for purposes other than those for which they were designed. Do not exceed their carrying capacity. Failure to follow these guidelines or the product's instructions will void the warranty.
- All loads must be secured using the provided straps.
- Review all instructions and warranty information carefully.
- Not for use on trailers or towed vehicles.
- Not for offroad use.
- Keep bicycle tires away from hot exhaust.

### WARNINGS / LIMITATIONS

- Carrying capacity should not exceed designated carrying capacity for specific model.
- Check tightness of all bolts and straps periodically.
- Not intended for tandems or recumbents.
- Do not exceed weight per class of receiver
- Do not install on trailer or towed vehicle.
- Failure to use strap may result in loss of bicycles.
- Replace Worn or Torn Straps