

PSHV18000 WINCH

PIERCE

PULLING FOR YOU



CATEGORY	WINCH
-----------------	-------

PART NO.	PSHV18000
-----------------	-----------

PRODUCT DESCRIPTION	18,000 lb Hydraulic Industrial Winch
----------------------------	--------------------------------------

SPECIFICATIONS	
RATED LINE PULL	18,000 lb
LINE SPEED	23 fpm @ 15.9 gpm
OPERATION PRESSURE	2,175 psi
MAX OIL FLOW	15.9 gpm
HYDRAULIC MOTOR	9.5 in ³ / rev
GEAR RATIO	2-stage planetary gear 19.4:1
WINCH CONSTRUCTION	Aluminum die cast housings with steel drum
CLUTCH	Rotating ring gear
BRAKE	Spring applied drag brake together with over-center valve supplied
ROTATION OF WINCH	Underwound
DRUM BARREL DIAMETER	4"
DRUM FLANGE DIAMETER	9.9"
DISTANCE BETWEEN FLANGES	10"
MOUNTING BOLTS PATTERN	12" x 4.5" 14.5" x 6.7"
WIRE ROPE RECOMMENDED	1/2" x 165'
WINCH WEIGHT	158.7 lb
GROSS WEIGHT	194.0 lb
WINCH DIMENSIONS (LxWxH)	27.1" x 11.4" x 11.3"
BOX DIMENSIONS (LxWxH)	28.1" x 16.3" x 12.2"

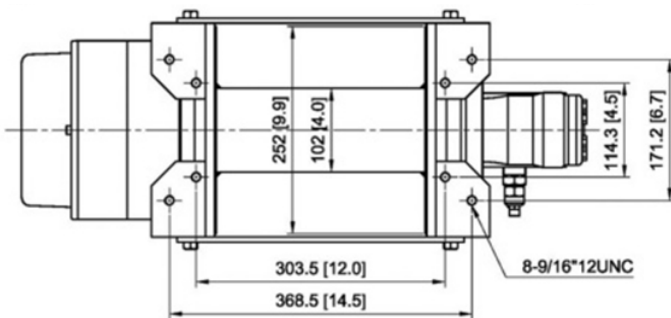
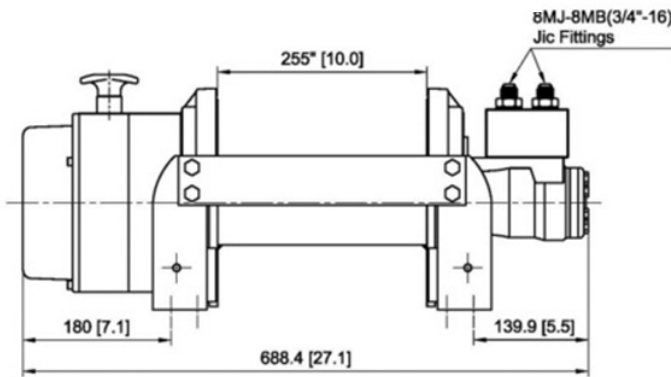
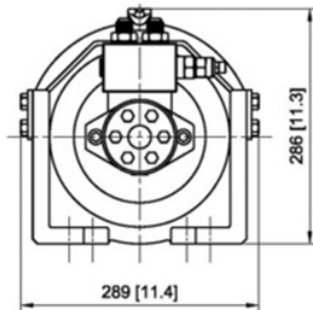

LINE SPEEDS			
LAYERS OF WIRE ROPE	PULL (LB)	WIRE ROPE (FT)	SPEED (@ 15.9 GPM)
1	18,000 lb	23.3 ft	23.0 fpm
2	14,767 lb	51.5 ft	28.5 fpm
3	12,500 lb	85.0 ft	33.8 fpm

Pierce puts everything within reach.

Choose reliable winches offered on our website.