

PSHDH20000 WINCH

PIERCE

PULLING FOR YOU

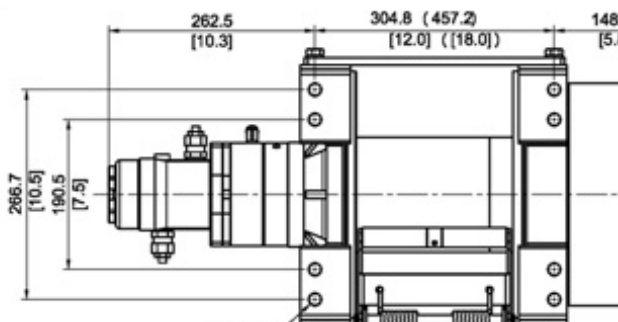
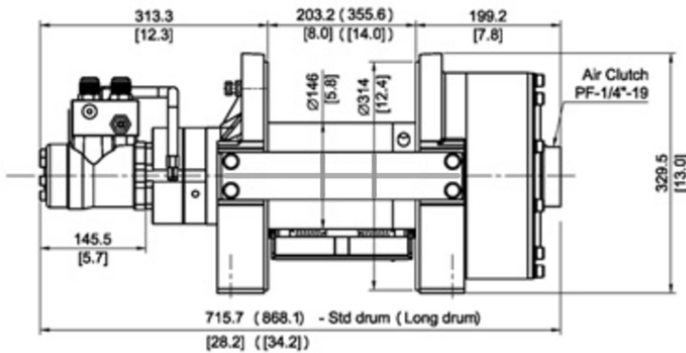
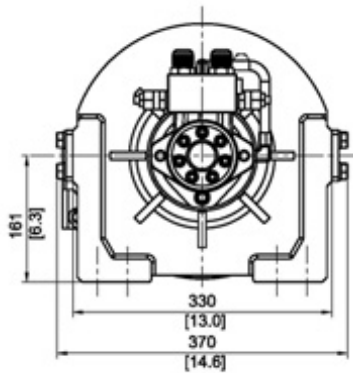

CATEGORY WINCH

PART NO. PSHDH20000

PRODUCT DESCRIPTION

20,000 lb Hydraulic Industrial Winch

SPECIFICATIONS

RATED LINE PULL	20,000 lb
LINE SPEED	23 fpm @ 15.9 gpm
OPERATION PRESSURE	2,175 psi
MAX OIL FLOW	15.9 gpm
HYDRAULIC MOTOR	9.5 in ³ / rev
GEAR RATIO	2-stage planetary gear 30:1
WINCH CONSTRUCTION	Aluminum die cast housings with steel drum
CLUTCH	Output shaft disengaged, air spool
BRAKE	Multidisc brake
ROTATION OF WINCH	Underwound, air spool
DRUM BARREL DIAMETER	5.8"
DRUM FLANGE DIAMETER	12.4"
DISTANCE BETWEEN FLANGES	14"
MOUNTING BOLTS PATTERN	7.5" x 18" 10.5" x 18"
WIRE ROPE RECOMMENDED	9/16" x 250'
WINCH WEIGHT	331 lb
GROSS WEIGHT	380 lb
WINCH DIMENSIONS (LxWxH)	34.6" x 14.6" x 13.0"
BOX DIMENSIONS (LxWxH)	Shipped in crate or pallet individually

LINE SPEEDS

LAYERS OF WIRE ROPE	PULL (LB)	WIRE ROPE (FT)	SPEED (@ 15.9 GPM)
1	20,000 lb	23 ft	23 fpm
2	17,017 lb	49 ft	27 fpm
3	14,813 lb	79 ft	31 fpm

Choose reliable winches offered on our website.