

Roof Rack Installation Instructions

CAUTION: Do not use the mounting hardware contained in this roof rack kit for installation on Fiberglass or Composite Plastic surfaces. Supplemental hardware pack, part# HWAVTC-UV, is required for installation on such non-metal surfaces.

CONTENTS: 2 - side rails, 2 - Left end supports and mating covers; 2 - Right end supports and mating covers; 4 - Universal Neoprene end support pads, 2 - Crossbars; 4 - Crossbar Connector Assemblies; 5 - PVC Roof Slats; 1 - hardware pack containing 8- #8x5/8" self-threading truss-head screws, 12- #10x3/4" waxed-tip pan head screws, 4-1/4" Stainless Steel Flat Washers, 2-Side Rail Center Posts and Neoprene Pads (68" & 78" Rails) or 4-Center Posts and Neoprene Pads (88" Rails); 2- #10x1" waxed-tip oval-head screws (68" & 78" Rails) or 4-screws (88" Rails); 1-5/32" Allen wrench; 1- instruction sheet.

Tools required: Phillips screwdriver; electric drill; 1/8" drill bit; center punch; pencil or marker.

1) As a "universal" roof rack designed to fit several different vehicles, the "bow / curvature" of the side rails may or may not exactly match the roof contour of a particular vehicle. **NOTE:** The rails should be "dry fit" to the roof panel before assembling the roof rack. Carefully place one of the rails (without end supports or center support posts) on the vehicle roof in the approximate location to be installed. The curvature of the rail should approximate the roof contour. If rail is under-curved and there is more than a 3/16" space between the ends of the rail and the vehicle roof panel, or over-curved and there is more than a 3/16" space between the center of the rail and the roof panel, "bench adjusting" the curvature of the rails is required. Adjust by suspending the rail between two points (4x4 wooden blocks, two tables, etc). To increase the curvature, start with the rail upside down; to decrease the curvature, start with the rail right side up (see appropriate illustration below). With hands spaced shoulder-width apart, apply sufficient pressure to the rail to increase or decrease the curvature as desired. Repeat this process for both rails.

Important Note: While made of extruded aluminum, the rails are heat-treated for added strength. Therefore, several applications of adequate "springing" pressure may be required to modify the curvature of the rails.



Increase Rail Curvature-Rail Upside Down



Decrease Rail Curvature-Rail Right Side Up

2) Slide center posts into groove on bottom of rails (applicable only on side rails of 68" or longer) as shown in Diagram 1 below.

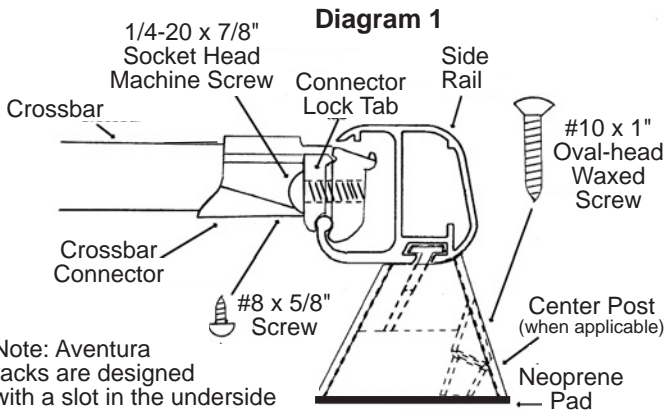

Note: Aventura racks are designed with a slot in the underside of the connectors to enable rack width to be adjusted to accommodate a broader range of roof sizes as well as those roofs having non-parallel body seams and/or rib patterns. The head of the #8 screw acts as an adjustment stop (re: Step 5 on Page 2 of this instruction sheet).

3) Slide crossbar connectors into opening on inside of rails as shown in Diagram 1, positioning relatively equidistant from each end of rails. Loosely tighten connector lock tab screws using 5/32" allen wrench provided.

4) Install end supports to side rails using the #8 x 5/8" self-threading screws as shown in Diagram 2 below. Do not tighten screws completely at this point.

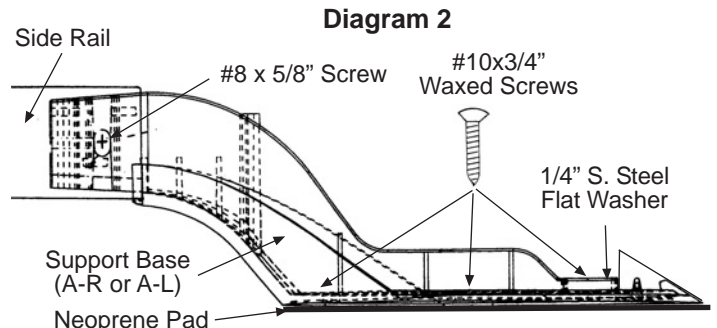

- 5) Install crossbars into crossbar connectors and secure with #8 x 5/8" screws thru slot-opening in connector and into pre-drilled holes in bottom of crossbars as shown in Diagram 1 on Page 1 of this instruction sheet. Note: The "slip-joint" style connectors provide limited, non-parallel installation of side rails on vehicles having rib patterns or roof panel seams that are not parallel to each other. Typically rails should be installed parallel to each other.
- 6) Place assembled rack in desired position on vehicle roof. If center posts are included in the unit, the post should be positioned approximately midway along the length of the rails. Mark locations of all mounting holes.
- 7) Place roof slats evenly spaced left to right and running parallel to side rails. If the vehicle roof has "raised ribs" formed in the roof panel, the roof slats should be positioned on top of said ribs provided the rib surface is wide enough. On vehicles with more than 5 ribs in the roof, the roof slats should be installed on the 4 interior center ribs. Mark location of all slats being used.
- 8) Remove the rack and roof slats from vehicle roof. Clean the roof where the slats will be located, using an adhesion cleaner/promoter such as Pro-Bond, Tite-R-Bond, etc. If such a promoter is not available, denatured alcohol or acetone should be used to clean the roof panel.
- 9) Peel back several inches of the red liner on the slat tape and reposition the slat in the marked location, pressing firmly at the point of adhesion to the roof panel. Continue peeling tape liner from underneath the slat and press firmly to adhere the slat to roof. Repeat for each slat being installed. NOTE: Do Not wash vehicle for 48 hours to insure proper adhesive curing.
- 10) Lightly center punch each marked mounting hole location. Drill fastener pilot holes using 1/8" drill bit taking care not to allow drill bit to penetrate vehicle headliner. Clear all metal drill chips from roof panel and apply a coat of primer or rust inhibitor to the bare metal edges of each hole.
- 11) Reposition rack on roof panel and place one neoprene pad underneath each end support and center support post (if included) and the roof panel, insuring that pad orientation provides proper alignment of screw holes in pad and support, then install using the #10 x 3/4" waxed screws as shown in Diagram 2 on Page 1 of this instruction sheet.
IMPORTANT: At outermost hole in each end support, place a 1/4" Stainless Steel flat washer (included) under head of each screw. Note: Use #10 x 1" Oval Head waxed screws to secure center posts (if included) as shown in Diagram 1 on Page 1.
- 12) Loosen the #8 x 5/8" support-to-rail screws approximately 2-3 complete turns to allow installation of the support covers.
- 13) Position a mating support cover (A-L cover to A-L support; A-R cover to A-R support) as shown in diagram below with the vertical blade of the cover sliding into the gap between the side wall of the end support tongue and the center wall of the rail extrusion. With blade correctly inserted/aligned at the end of rail, rotate the cover downward until it contacts the support base, and apply moderate downward pressure at the tapered end of the cover until the lock tabs at the end of the cover snap into the mating tab slots at the end of the support base.
- 14) With covers properly installed, securely tighten the four #8 x 5/8" support-to-rail screws while applying slight pressure to the top of each cover to insure proper seating of the cover to the mating support base.

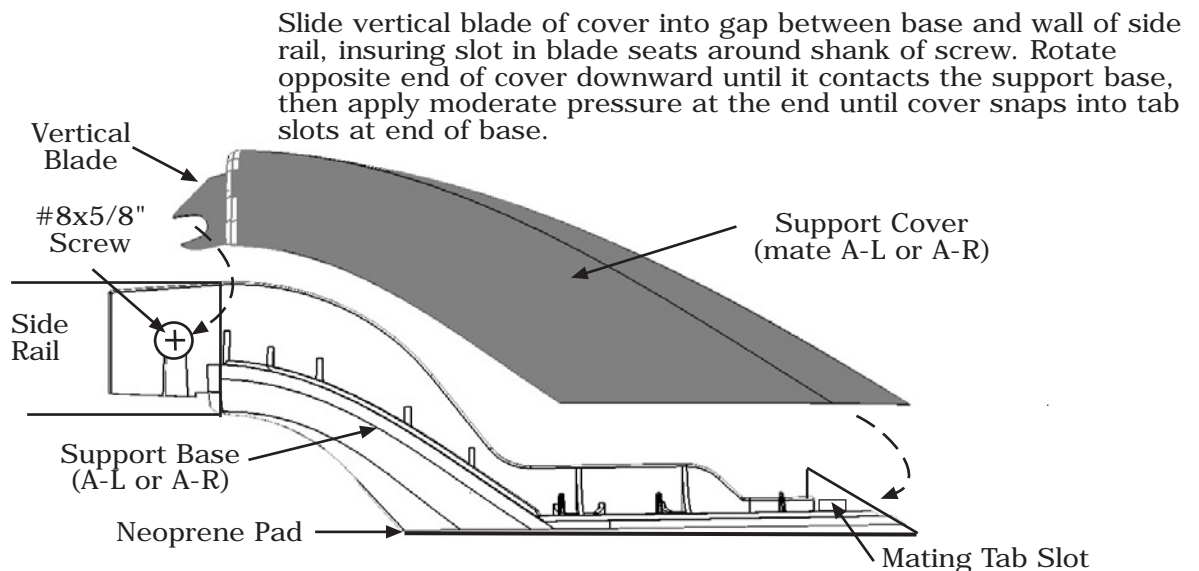

IMPORTANT NOTE: This Roof Rack Kit contains 4 Rail Supports with mating Right and Left Bases and Covers. These components are identified by "A-L" or "A-R" molded on the top surface of each Base and inside surface of each Cover. When installing Covers, insure that Covers are mated with appropriate Bases.

Aventura

ROOF RACK INSTALLATION INSTRUCTIONS

(68" and 78" RAIL LENGTHS)





ROOF RACK INSTALLATION INSTRUCTIONS

(68 and 78" RAIL LENGTHS)

NOTE: Perrycraft's products are manufactured to be installed into the skin of the roof panel of vehicles. They are not designed to line up or be installed at the factory fitment points available on some vehicles.

NOTE: The included hardware pack contains screws for securing this rack to a sheet metal roof or metal surface.

NOTE: Perrycraft, Inc. manufactures racks and rails that are size specific, not vehicle specific. Therefore, the bow of the rails (front to back) may need adjusting. Place the rails (without the feet) on the roof in the desired location. Ideally, the rails should match the roof curvature. The ends of the rails should touch the roof and the center should be no more than 3/16" off the roof surface. The rails can be adjusted (more bow or less bow) by placing the ends of the rails on supports and either pressing down from the top (to take away bow), or pressing down from the bottom (to add more bow). Rails are heat treated aluminum, therefore, very strong. Several attempts of adjustment may be required to get the correct curvature.

Retain these instructions. They are useful if contacting Perrycraft for information, parts, or service.

ITEMS NEEDED (NOT INCLUDED)

- Measuring Tape
- Masking Tape
- Marker
- Drill
- 1/8" Drill Bit
- Phillips Screwdriver
- Rag and Cleaner for roof

CONTENTS:

- 2 – Side Rails (Rails will be 14" shorter than last two numbers of part number (ex. AV3648-B, rails are 34"))
- 2 – Cross Bars (Cross bars will be 4" shorter than the first two number of part number (ex. AV3648-B, cross bars are 32"))
- 2 – Left Stanchions
- 2 – Left Stanchion Covers
- 2 – Right Stanchions
- 2 – Right Stanchion Covers
- 2 – Center Posts
- 4 – Cross Bar Connectors
- 1 – Hardware pack
 - 4 – 1/4" Flat Washer
 - 1 – 5/32" Allen Wrench
 - 8 – #8 x 5/8" Truss Phillips A-B
 - 12 – #10 x 3/4" Pan Phillips Screw – Waxed
 - 2 – #10 x 1" Oval Phillips Screw – Waxed
 - 4 – Neoprene Stanchion Pads (Universal)

ASSEMBLY AND INSTALLATION:

Installation will include assembling the rack, placing it on the roof and marking the hole locations, removing the rack and drilling holes at the marked locations, cleaning the roof, and securing the rack to the roof.

1. Slide cross bar connectors onto cross bars (connector bracket facing out) with the slots of the connectors on the bottoms of the rails where the pre-drilled holes are.

2. Install #8 x 5/8" screws into cross bars through the slot opening of the connectors.

NOTE: Aventura's slip joint cross bar connectors are designed to give a greater opportunity for installations when the rails can't be installed perfectly parallel. Best effort should be made to install the rails parallel and with at least a portion of the cross bars sitting inside of the channels of the rails.

3. Loosen the connector screws with the Allen wrench and slide the cross bars onto the rails. Crossbars should be placed approximately 4 inches from the ends of the rails, so that the installation will be as "square" as possible.

4. Slide one post into groove on bottom of each rail and place in the center.

5. Insert stanchions into rails. The open screw hole on the upper portion of the stanchion will be on the open side of the rail. Line up the holes and loosely install the remaining #8 x 5/8" screws.

6. Place assembled rack onto roof in desired location (approximately 2-3 inches forward of the back hatch joint) and adjust as necessary to get the rails as parallel as possible.

7. Mark the three hole locations in each foot and the one hole location in each post and remove rack.

8. Drill pilot holes where marked using 1/8" drill bit going no deeper than 1/2", being careful not to penetrate interior headliner. Clean roof, removing all drill chips.

9. Place rack back onto roof, lining up with drilled holes. Place neoprene pads under each stanchion, flipping them as necessary to the lineup with the foot profile.

10. Put one 1/4" washer over the hole that is closest to the "toe" of the stanchions.

11. Using hand screwdriver, secure rails to roof using supplied #10 x 3/4" pan head waxed screws. Do not overtighten. Snug is enough.

12. Insert covers to matching stanchions (A-L cover to A-L stanchion, A-R cover to A-R stanchion). The vertical blade will insert at the rail/stanchion connection, with the cutout going around the screw shank. Press the toe of the cover downward until the cover snaps into the tab slots on the stanchion.

13. Tighten the rail/stanchion connection screws at all four locations.

14. If installed correctly, cross bars should be able to move to various positions along rails. Tighten cross bar connectors when satisfied with location of cross bars.

NOTES AND WARNINGS:

- All fasteners, knobs, and securing methods should be checked frequently and tightened as necessary.
- Going through a brush car wash is not recommended with this rack installed.
- Do not use rack if a part is cracked or broken.
- External roof racks do not increase the GVWR of the vehicle. Total occupant and cargo load should not exceed the manufacturer's rated vehicle capacity.
- Maximum load for this rack is 110 pounds, evenly distributed on the cross bar assemblies. Torque applied to any straps, cords, etc. holding down gear or equipment also increases the "load weight" to the cross bars and roof.
- Large or flat items such as plywood, ladders, lumber, hang gliders, canoes, kayaks, etc., can trap air and create wind lift. Secure the ends of long objects directly to the front and back bumpers or tie-down positions.
- Bulky or tall loads can create tremendous horizontal wind resistance from headwinds and crosswinds. Extreme caution should be used when transporting such loads.

Perrycraft, Inc. does not assume responsibility for style or size of rack installed, improper rack installation, exceeding rack load limit, load securing methods, vehicle roof strength, wind lift or any other factors beyond its control. Wind noise is a definite when carrying items on the cross bars. It is also possible with nothing on the bars. Make sure all connections are tight. Sometimes wind noise can be alleviated by moving the front cross bar toward the rear of the vehicle. If wind noise persists, a wind fairing may need to be purchased and installed.