

PERRIN

PERFORMANCE

Front Control Arm Front Bushing

For 2008+ WRX/STI/BRZ

Thank you for purchasing this PERRIN product for your car! Installation of this product should only be performed by persons experienced with installation of aftermarket performance parts and proper operation of high performance vehicles. If vehicle needs to be raised off the ground for installation, the installer must use proper jacks, jack-stands and/or a professional vehicle hoist for safety of the installer and to protect property. If the vehicle is lifted improperly, serious injury or death may occur! Please read through all instructions before performing any portion of installation. If you have any questions, please contact our tech department prior to starting installation.

SUSPENSION INSTALLATION NOTE

Installation of this product is a modification to the vehicle suspension. As a result, the vehicle may handle differently than that of factory-equipped vehicles. As with any vehicle extreme care must be used to prevent loss of control or roll-over during sharp turns or abrupt maneuvers. Always wear seat belts, and drive safely, recognizing that reduced speeds and specialized driving techniques may be required. Failure to drive this vehicle safely may result in serious injury or death. Do not drive this vehicle unless you are familiar with its unique handling characteristics and are confident of your ability to maintain control under all driving conditions. Some modifications (and combinations of modifications) are not recommended and may not be permitted in your state or country. Consult your owner's manual, service manual, instructions accompanying this product, and local laws before undertaking these modifications. You are responsible for the legality and safety of the vehicle you modify using these components.

SPECIAL NOTES:

- The use of a factory service manual is highly recommended. These can be purchased, or downloaded online at <http://techinfo.subaru.com>
- It is critical that all bolts and nuts are tightened, improper tightening can cause serious injury or death.
- A 4 wheel alignment is not needed after installation of this part.

Parts Included with the PERRIN Front Control Arm Front Bushing:

- (4) Urethane Bushings for Control Arm
- (2) Steel Sleeves
- (1) Urethane Grease Packet

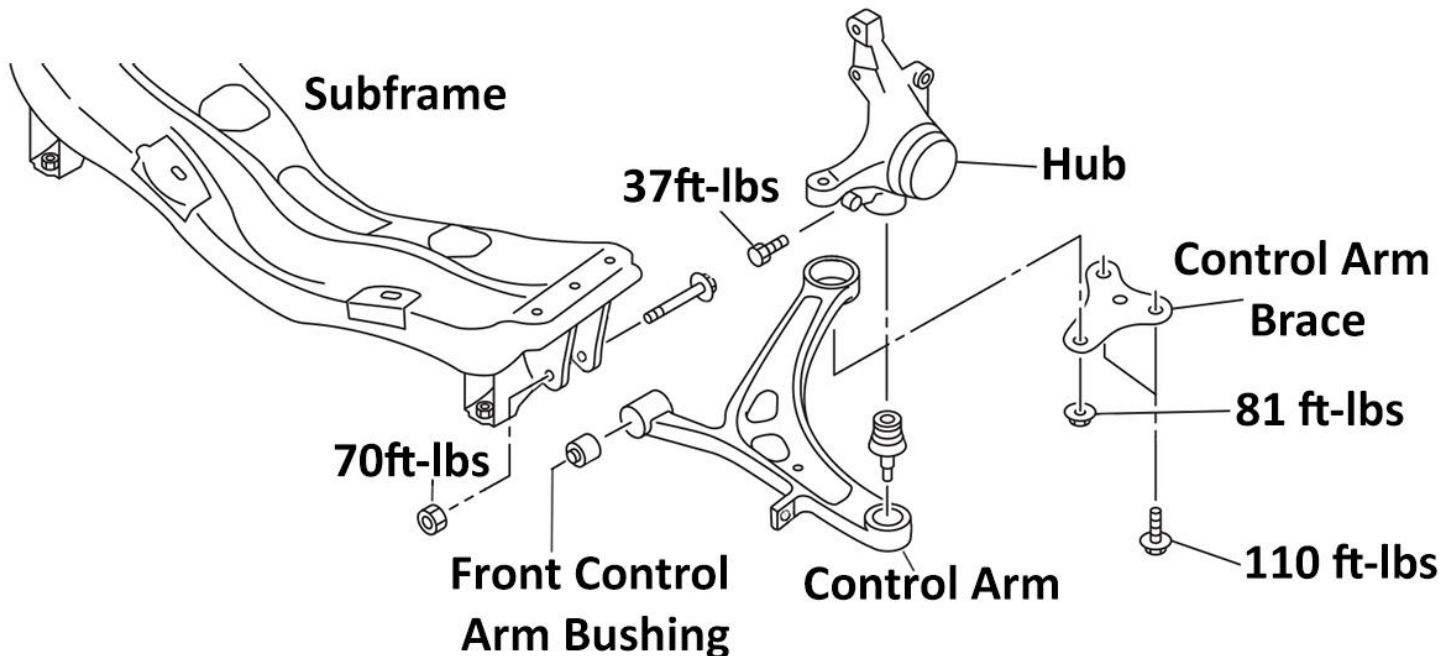

Removal and Installation:

- 1) Park car on a smooth level surface. Using suitable commercial vehicle hoist or floor jack, raise vehicle onto jack stands. NEVER WORK UNDER A VEHICLE SOLELY SUPPORTED BY A JACK! DEATH OR INJURY MAY OCCUR.
- 2) Using factory service manual for reference, remove both front transverse links from vehicle. The basic steps are: Remove nuts and bolts securing control arm brace, remove bolts securing outer ball joint to hub, remove bolt and nut securing front control arm bushing to sub frame.
- 3) Using proper dies or press tools, remove OEM bushing from control arm.

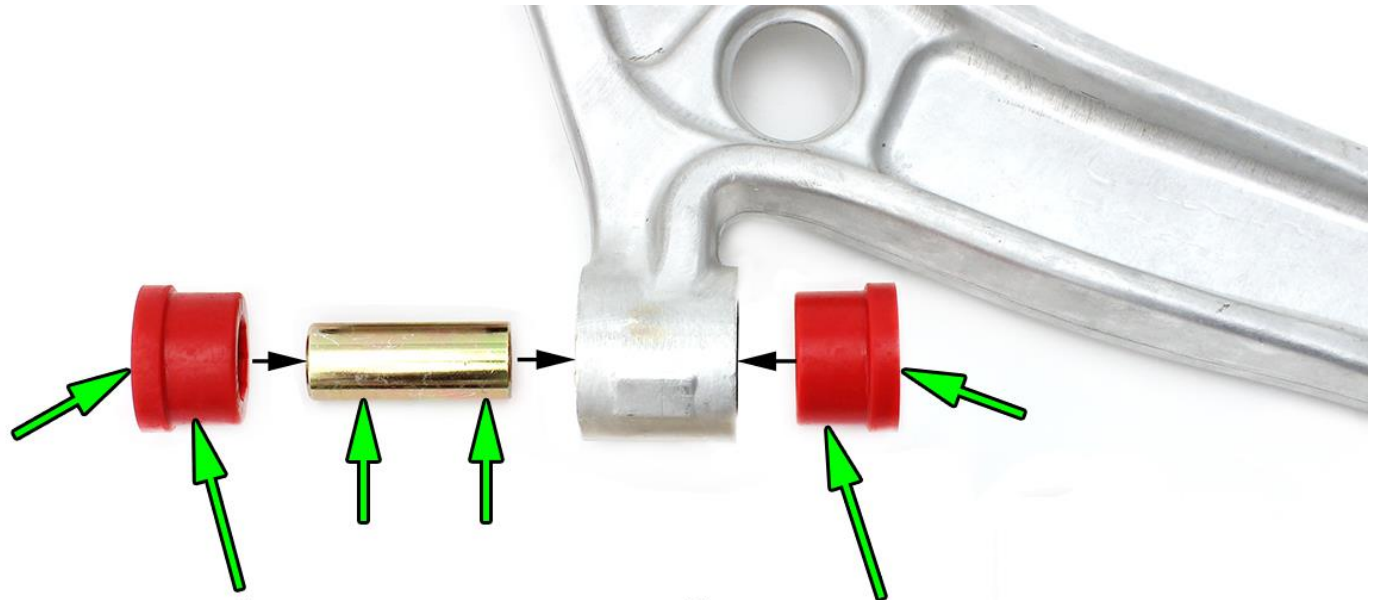

Make Sure and Grease Here

- 4) Apply supplied grease to outsides of both bushings and press them into the control arm as shown above.
- 5) Apply supplied grease to outsides of supplied steel sleeves as well as to insides of bushings. **Note: Error on using too much grease rather than too little. Excessive grease will just push out and can be wiped off after installation.**
- 6) Press sleeves into bushings. Make sure and push them back and forth a few times to move the grease around.
- 7) Reinstall control arms back into car following factory service manual. See above diagram for proper torque specs for all bolts removed.
- 8) Lower vehicle from hoist or jack stands.
- 9) Road test vehicle and listen for any clunks or abnormal sounds. If any abnormal sounds are found, recheck installation.
- 10) If you live in an area that is highly corrosive or roads are salted in the winter time, re-greasing of bushings every other year may be required, or whenever they start to become squeaky.