

PERRIN

PERFORMANCE

BRZ/FR-S License Plate Relocate Kit

Thank you for purchasing this PERRIN product for your car! Installation of this product should only be performed by persons experienced with installation of aftermarket performance parts and proper operation of high performance vehicles. If vehicle needs to be raised off the ground for installation, the installer must use proper jacks, jack-stands and/or a professional vehicle hoist for safety of the installer and to protect property. If the vehicle is lifted improperly, serious injury or death may occur! Please read through all instructions before performing any portion of installation. If you have any questions, please contact our tech department prior to starting installation.

Parts Included with the PERRIN Front License Plate Relocate Kit:

- (1) PERRIN Offset Plate holder
- (1) PERRIN BRZ/FR-S Tow Hook Stem
- (1) 7/16-20 SS Hex Bolt, Black Oxidized
- (4) M6x10mm Button Head SS Screws
- (4) M6 SS washers
- (7) 7/16" SS Flat washers, Black Oxidized
- (1) M4 Hex Key
- (1) PERRIN Plate Frame
- (1) Anti-seize Packet

Special note: PERRIN plate relocate must be removed when going through automated car wash or damage will occur to plate relocate!

Installation of PERRIN License Plate Holder:

- 1) Locate and remove front tow hook cover on front bumper. Take care in removing or damage to your paint can occur. A flat head screwdriver with a towel behind it is a good idea.
- 2) Install Tow Hook Stem into threaded hole using 19mm or ¾" socket and tighten to roughly 50ft-lbs. If hole looks rusty or corroded (or you live in an area where roads are salted in winter) apply a small amount of included Anti-Seize to threads, and spray some penetrating oil into the hole before installing.

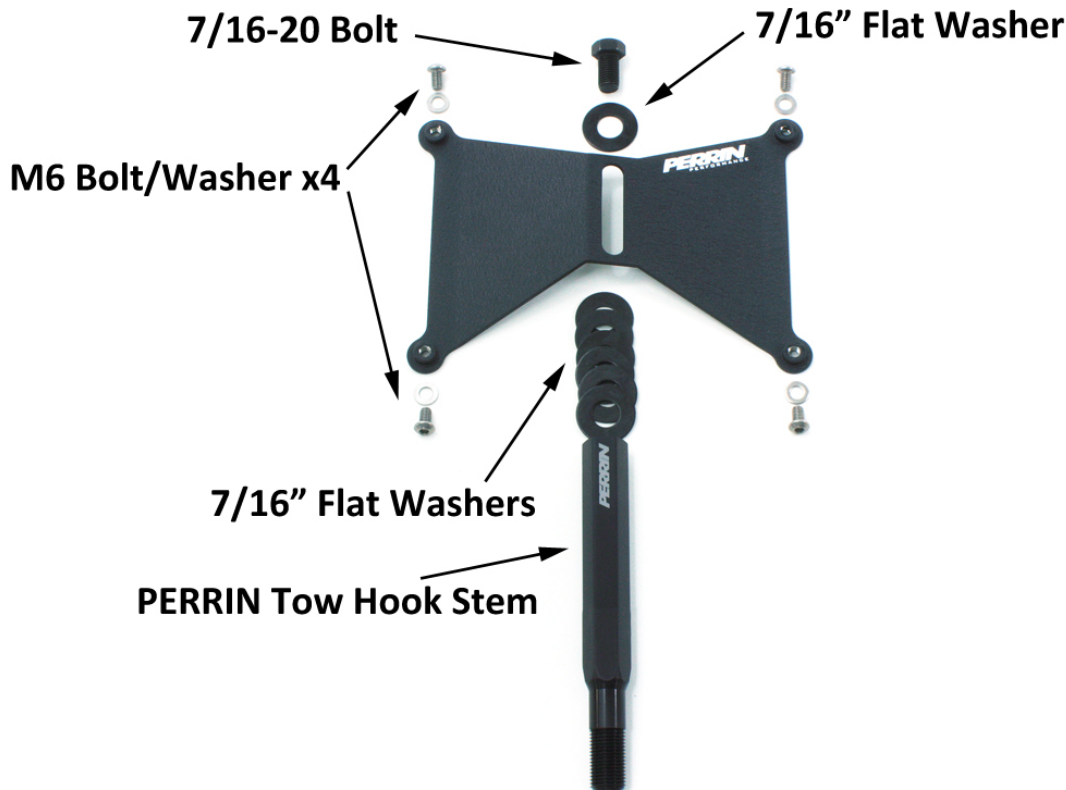

- 3) Install PERRIN plate holder to stem, use at least (1) flat washer between stem and holder and (1) washer between holder and bolt. Align plate holder to desired position and tighten bolt to roughly 30ft-lbs. Use included extra washers to adjust plate holder to desired position.
- 4) Install license plate and PERRIN Plate Frame to holder, using supplied M6 bolts and washers. Hand tighten bolts only!
- 5) Ensure License plate does not interfere with car in anyway, or damage WILL occur. If plate needs to be moved away from car add washers between Tow Hook Stem and Plate Holder.
- 6) After a 2-3 days of driving, recheck tightness of all hardware to ensure plate and holder have not come loose. NOTE: We recommend checking the tightness of hardware once a month to ensure plate never falls off.