

PERRIN

PERFORMANCE

2015+ WRX/STI RADIATOR SHROUD

Thank you for purchasing this PERRIN product for your car! Installation of this product should only be performed by persons experienced with installation of aftermarket performance parts and proper operation of high performance vehicles. If vehicle needs to be raised off the ground for installation, the installer must use proper jacks, jack-stands and/or a professional vehicle hoist for safety of the installer and to protect property. If the vehicle is lifted improperly, serious injury or death may occur! Please read through all instructions before performing any portion of installation. If you have any questions, please contact our tech department prior to starting installation.

Parts Included with the PERRIN Radiator Shroud:

- (1) PERRIN Left Radiator Shroud (With PERRIN Logo)
- (1) PERRIN Right Radiator Shroud for Stock Intake (smaller shroud with rubber trim)
- (1) PERRIN Right Radiator Shroud for Aftermarket Intake (larger shroud)
- (3) M5x10 Socket Cap Screw
- (3) M5 SS Lock Nut
- (1) M3 Hex Key
- (1) Foam Tape 2"x1"x14"

Special Notes:

- Shrouds for both stock intake (with air scoop) and aftermarket intake (no air scoop) are included. Some aftermarket intakes may use the air scoop and it is up to you to decide which is best for your installation.
- At some point you might change intake systems, which may require changing the right side of your radiator shroud. Extra hardware and foam tape is included to allow you to change the right side radiator shroud in the future.

Right Side for Aftermarket Intake

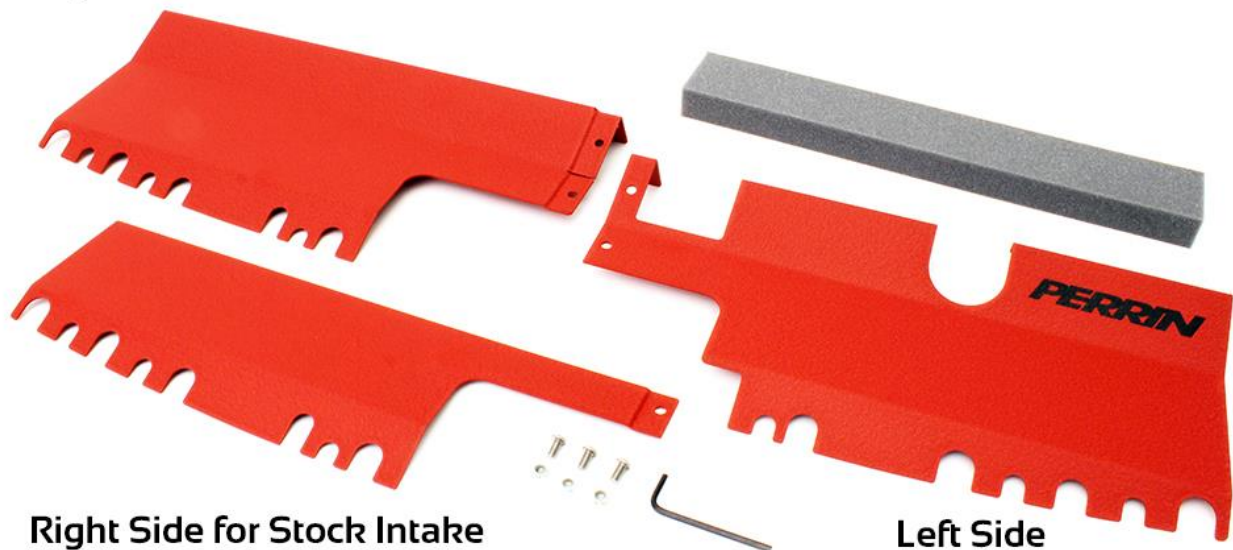

Right Side for Stock Intake

Left Side

INSTALLATION

- 1) Wait at least 2 hours for engine to completely cool down, then remove radiator cap from radiator.
- 2) Assemble radiator shroud using supplied M5 hardware.
 - a. For intakes that do not utilize the OEM air scoop, assemble left shroud and right larger shroud.
 - b. For intakes that utilize the OEM air scoop, assemble left shroud and right smaller shroud. If desired, install left over bolts and nuts into empty holes. This allows you to have the hardware ready if you install an aftermarket intake.
- 3) Install supplied foam tape to both left and right edges making sure to trim excess off ends. See picture after step 12.
- 4) Open hood and locate rubber trim surrounding hood latch. Pull rubber trim from hood. **Note: This may leave behind small plastic buttons which can be removed with small pliers or panel removal tools.**



- 5) Using large pliers, rotate upper radiator hose clamp so it points straight up. **Note: This clamp has a locking feature that may lock during rotation. If this happens make 100% sure it is unlocked and clamp is tight on hose, or a large coolant leak will occur.**
- 6) Remove coolant overflow tank on left side of engine by depressing small clip on radiator fan shroud.



- 7) Using a panel popper tool or flathead screw driver, remove (3) plastic fasteners from upper bumper metal trim piece.
- 8) Remove (6) 10mm bolts from upper bumper trim piece.

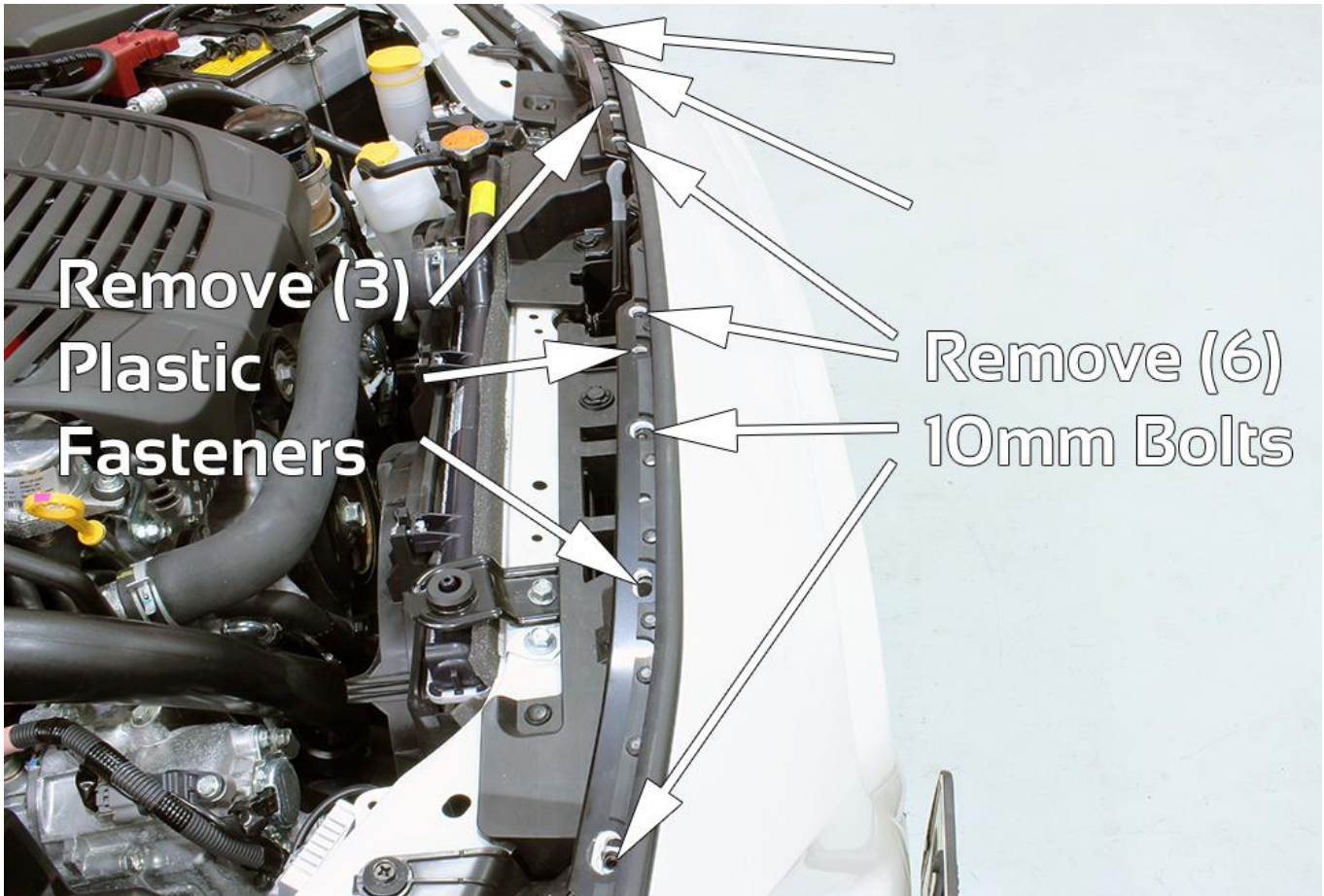

- 9) Loosen radiator fan shrouds to make room for tabs on PERRIN Radiator Shroud.
- a. For intakes that do not utilize the OEM air scoop, loosen (4) 10mm bolts (2 on each radiator fan) roughly 5 full turns or until you can move the fan away, roughly 1/8".
 - b. For intakes that utilize the OEM air scoop, loosen (2) 10mm bolts (left side radiator fan) roughly 5 full turns or until you can move the fan away roughly 1/8".

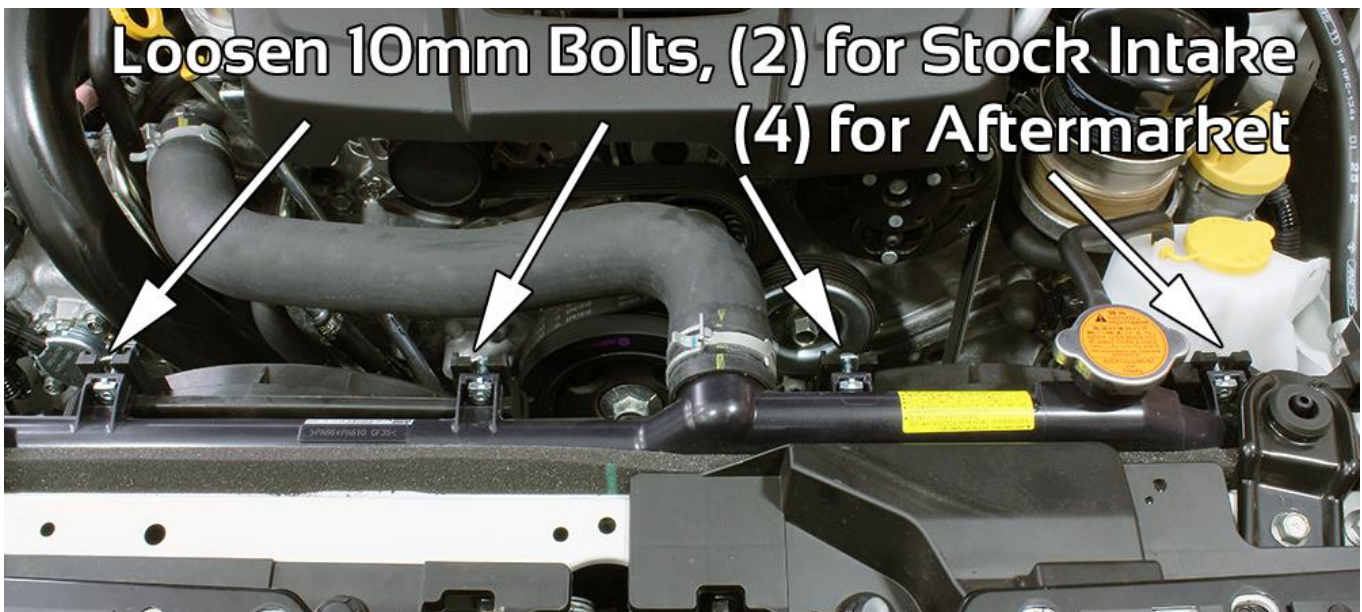

- 10) Using picture below for reference, lift up bumper cover and place PERRIN Radiator shroud between bumper and chassis. **Note: Do not place between upper bumper metal trim piece.**
- 11) Using picture below for reference, place rear tabs of PERRIN Radiator shroud between radiator fans and radiator (where 10mm bolts were loosened in step 9).

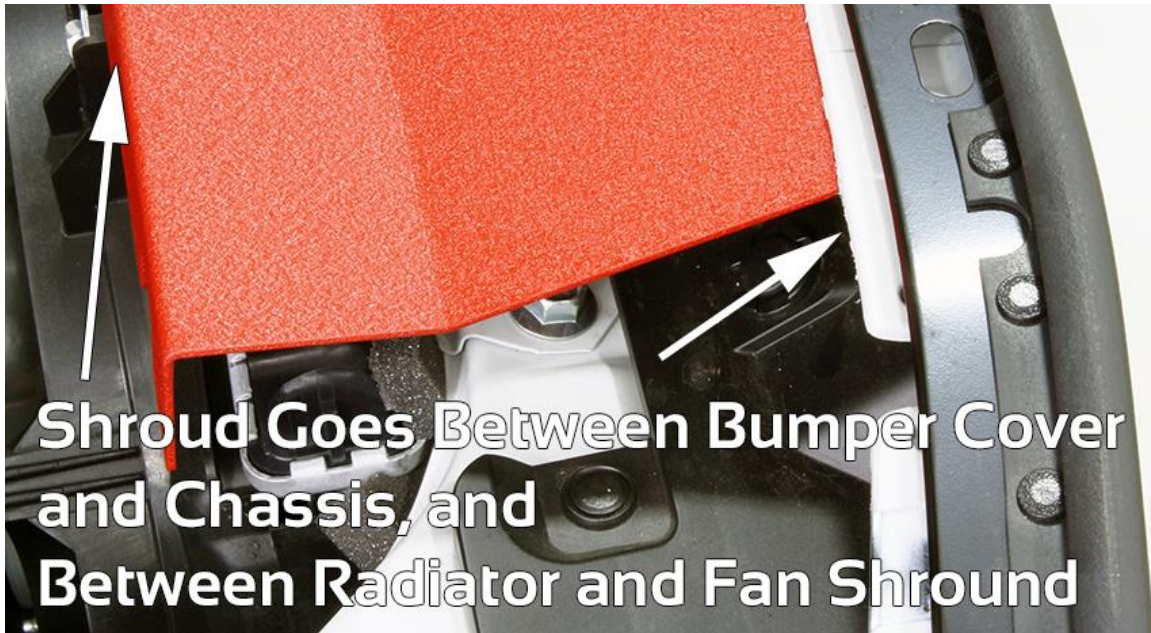

- 12) Align shroud with bumper cover, press shroud down toward radiator and tighten 10mm bolts loosened in step 9.



- 13) Install plastic fasteners into upper bumper metal trim piece, then install 10mm bolts into upper bumper metal trim piece. Hand tighten bolts and recheck PERRIN Radiator Shroud alignment.
- 14) Snap coolant overflow tank back into radiator. Check and make sure lower section didn't become dislodged in locating tab.
- 15) Install radiator cap back into place.



- 16) Slowly close hood checking to ensure nothing comes in contact with PERRIN Radiator shroud. Make sure to fully latch hood after checking clearance.
- 17) Take car for test drive. You will know your radiator shroud is installed properly if your friends are envious of your engine bay when hood is lifted.