



## Technical Data Sheet

# Permatex<sup>®</sup> Muffler & Tailpipe Bandage

### PRODUCT DESCRIPTION

Permatex<sup>®</sup> Muffler & Tailpipe Bandage is an epoxy impregnated fiberglass bandage that is uniquely formulated to wrap around and chemically weld mufflers and tailpipes.

### PRODUCT BENEFITS

- Permanently repairs holes and leaks in exhaust systems
- Easy to use
- Resists temperatures to 800°F
- Seals out poisonous fumes

### TYPICAL APPLICATIONS

- Mufflers and tailpipes on automobiles, trucks, tractors, and farm equipment

### DIRECTIONS FOR USE

1. Clean off dirt and loose rust with sandpaper or wire brush.
2. Run the engine until muffler is warm to touch.
3. Peel back the protective coating on the bandage.
4. Wrap the bandage over the damaged area, overlapping    inch.

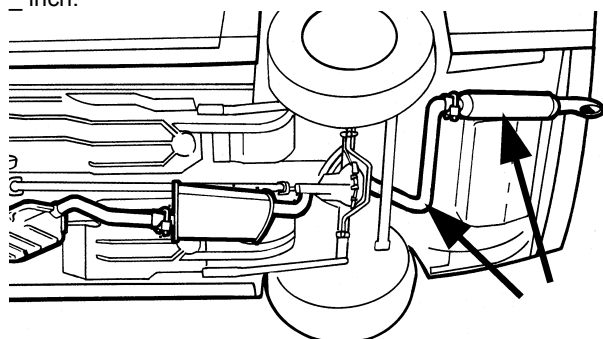

5. Support the bandage with wire or masking tape.
6. Run the vehicles' engine for 30 minutes. Heat from the exhaust welds the epoxy resin in the bandage to a solid coating.

### For Cleanup

1. Clean up with lacquer thinner.
2. Clean hands with a dry cloth or Permatex<sup>®</sup> Fast Orange<sup>®</sup> hand cleaner.

### PROPERTIES OF UNCURED MATERIAL

	Typical Value
Chemical Type	Epoxy impregnated fiberglass
Appearance	Black Coating
Odor	Odorless
Specific Gravity	None
Flash Point	None

### TYPICAL CURING PERFORMANCE

Permatex<sup>®</sup> Muffler & Tailpipe Bandage cures to a solid epoxy coating when engine temperatures reach operating levels.

### TYPICAL ENVIRONMENTAL RESISTANCE

Temperature Resistance	Typical Values
Continuous, °C (°F)	426 (800)

### GENERAL INFORMATION

This product is not recommended for use in pure oxygen and/or oxygen rich systems and should not be selected for use with chlorine or other strong oxidizing materials.

For safe handling information on this product, consult the Material Safety Data Sheet, (MSDS).

### ORDERING INFORMATION

Part Number	Container Size
80331 (MB-1)	84 sq. in. bandage, carded
80332 (MB-2)	120 sq. in. bandage, carded

### STORAGE

Products shall be ideally stored in a cool, dry location in unopened containers at a temperature between 8° to 28°C (46° to 82°F) unless otherwise labeled. Optimal storage is at the lower half of this temperature range. To prevent contamination of unused product, do not return any material to its original container.