

COOL-PACK

Radiator Cooling System

1981 to 1987 Chevrolet/GMC Pickups
1981 to 1991 Chevrolet/GMC Suburban, Yukon, Tahoe

Installation Instructions: Part No. 19513 (17" x 28-1/2")



PLEASE READ ALL OF THE INSTRUCTIONS BEFORE BEGINNING INSTALLATION OF THIS SYSTEM

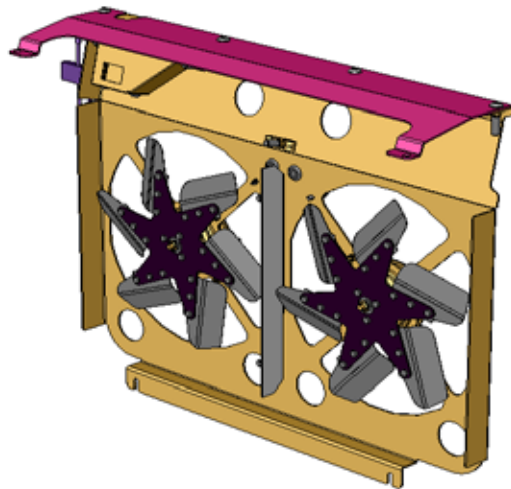

FRONT VIEW 19513 Shown

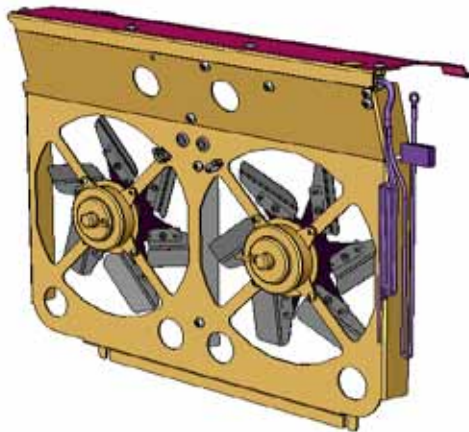

REAR VIEW 19513 Shown

Tools recommended:

Ratchet / socket set; 3/8 inch drive

Sockets, 6-point 9MM and 3/8 inch

Box wrench, 1/2 inch and Large adjustable wrench

Mini-screw driver, flat blade (supplied)

Notes:

1. Verify that your vehicle's cooling system is functioning correctly. It is important that the coolant is fresh and properly mixed per factory specifications. The radiator should be free of any corrosion or blockage. Cooling system should be filled to factory specified level.

2. Vehicles equipped with Heavy Duty / 4-Wheel Drive option will require the removal of the lower front skidpan, if so equipped.

3. Some GM applications feature an OEM thread-on fan clutch. Verify that you have the necessary tool on hand before beginning installation.

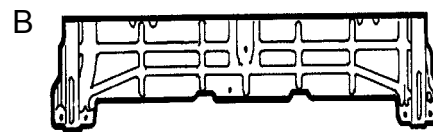
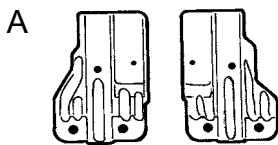

4. Some GM vehicles were designed with individual radiator left and right mounting brackets (illustration A) and some with one-piece upper radiator mounting bracket (illustration B).

Equipment removal (Retain all bolts and nuts):

1. Remove the two top shroud bolts [A].

2. Remove the bolts or clips that attach the upper half of the shroud to the lower half [B]. Remove the top half of the shroud.

3. Remove the two radiator mount bracket bolts [C]. DO NOT remove the extreme right and left bolts [D]!

4. Loosen and remove the four nuts that attach the fan clutch assembly to the water pump flange. Remove the fan clutch and fan assembly. Models with four (4) mounting studs on fan clutch unit will require their removal. To remove the studs, use the nuts just removed from fan clutch. Screw two (2) nuts (on top of each other) onto a stud, and then lock the nuts together. Place wrench on the inner nut and back the studs out of the fan clutch flange. Unlock nuts and repeat on the other studs. Install the four (4) bolts provided and tighten to 22-25 ft.-lbs. of torque. Note: Both 5/16"-24 and 8mm bolts are supplied. Determine which is correct for the water pump flange and discard the others.

5. Remove the lower shroud bolts from the radiator core support. Note: The lower radiator hose, engine oil, and/or automatic transmission lines may need to be gently repositioned.

6. Lift the lower half of the shroud up and out through the top of the engine compartment.

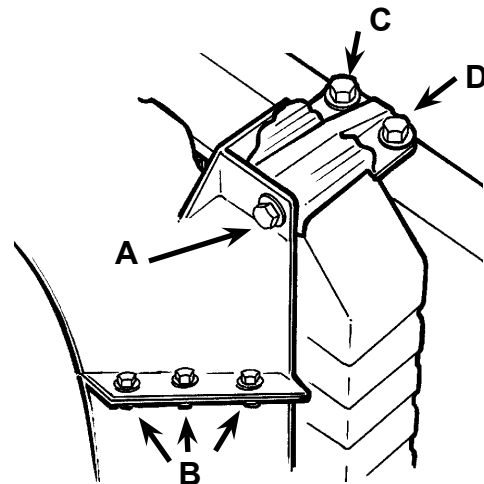

Cool-Pack Installation (Mechanical):

1. Install the two (2) supplied 1/4"-20 or M6 x 30mm bolts with spacer washers on each bolt into the two existing mount holes in the lower radiator shroud support. Use washers to set fan to radiator distance as called out in step 5. Finger-tighten a few turns only.

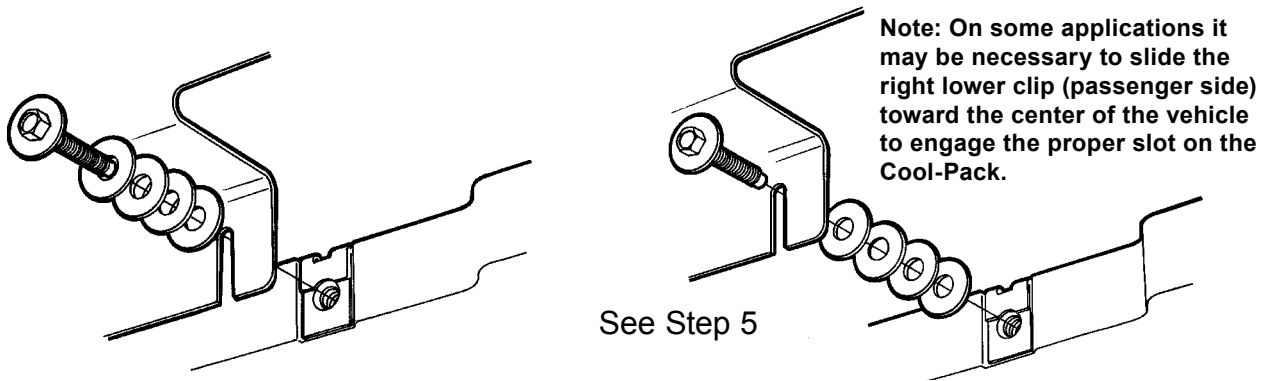

2. Attach the top plate to the top of the Cool-Pack Assembly using mounting holes in the outer position with the supplied hardware.

3. Lower the Cool-Pack Assembly into position on the radiator shroud support. Line up the slots in the angle flange with the bolts installed in step 1 above. Locate the angle flange between the spacer washers and the radiator core support. Carefully place the Cool-Pack Assembly on top of the radiator support in position where the top edge of the shroud was located, using the innermost holes. **NOTE: The Cool-Pack must be installed so that the Assembly edge does NOT come in contact with the wiring harness.**

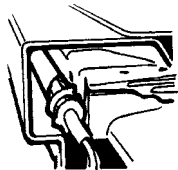

Incorrect position wire harness being pinched

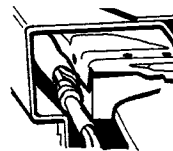

Correct position wire harness not pinched

4. Insert two (2) of the bracket bolts into the radiator support. Finger-tighten only [C] .

5. Measure the clearance between the Cool-Pack Assembly's side flanges and the radiator core. A **minimum of 1/8 inch clearance is required** between the radiator and the side and center flanges of the Cool-Pack Assembly. Next measure the distance between the radiator and the electric fan blades. If the distance is at least 1/2 inch, but no more than 1 inch, the Assembly will mount in the OUTER position. If the distance is greater than 1 inch, the Assembly will mount in the INNER position.

DO NOT PLACE THE ASSEMBLY IN ANY POSITION WHERE THE DISTANCE BETWEEN THE RADITOR

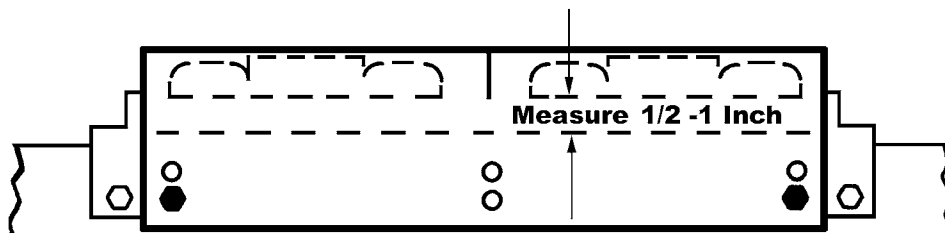

CORE AND THE ELECTRIC FAN BLADE IS LESS THAN 1/2 INCH, NOR MORE THAN 1 INCH!

6. With all the clearances noted, move the Cool-Pack Assembly in or out, utilizing the spacer washers on the bottom and the top mounting holes to achieve the optimum match to the tolerances that were detailed in step 5 above.

7. Insert the sensor probe through the foam pad, adhesive side out. Remove the adhesive backing and insert probe into radiator. The ideal probe location is three to five inches (3" to 5") below the top of the core in the center. Secure the probe wiring loom to prevent contact with the fan blades or any other moving parts. Note: It is recommended to install the probe before finalizing the Cool-Pack mechanical install. Access is best through one of the vent holes.
8. With the probe securely in place, tighten all top and bottom bolts until snug.
9. (Optional) Attach the radiator hose support assembly to the Cool-Pack Assembly, using clamp, bolt, and nut. An additional 1/4" hole will be needed depending on your application. Hold the nut in place with finger (through the vent holes), lining up to accept bolt. Tighten until snug.

Cool-Pack Installation (Electrical):

1. Disconnect the positive (red) battery cable. Remove the OEM bolt located in the end of the battery cable.
2. Inspect and clean battery cable. Reconnect the battery cable to the battery, using the brass connector bolt provided.
- 3a. Connect the blue wire to the A/C compressor clutch supply wire. To determine or identify the wire, find the location on the compressor where the wires are connected. Unwrap the factory tape enough to view the insulation colors. The supply wire is generally Green-with Black. **Note:** *If you are unsure or cannot locate the proper wire, it may be necessary to consult a repair manual or wiring schematic. Do not cut the A/C wire on the vehicle!* Use the provided wire splice-tap instead.
- 3b. If a manual turn-on switch is desired, and there is no A/C connected in the system, the blue wire can be energized from a manual toggle switch to turn the unit on.
- 3c. If the vehicle does not have air conditioning, and a manual turn-on switch is not desired, cut the blue wire and install the provided wire cap to the end of the wire.
4. Connect the fused power wire to the brass connector installed on the battery in step 2 above.
5. Connect the black wire to body ground. Recommended attachment points are underneath an upper radiator core support bolt, the negative battery pigtail, or drill 1/8" hole in (metal) core support, frame, or fenderwell and use either of the sheet metal screws provided. To ensure a better electrical connection, scratch or scuff the paint surface where you will be attaching the wire.

Cool-Pack Adjustment:

1. After vehicle has reached normal operating temperature, the preset temperature (approx. 195°F) controller can be adjusted for the fans to turn on at any temperature between 170°F-220°F.
2. Turn adjustment screw clockwise (CW) for a higher turn on temperature. Conversely, turn the screw counter clockwise (CCW) for a lower turn on temperature. **Note:** *Setting the turn-on temperature to lower than 185°F may affect vehicle emission control compliance.*