

REAR AXLE BEARING PULLER SET

W89326

This set includes three pullers for the applications listed below. The specially designed pullers allow for the removal of semi-floating rear axle bearings by firmly seizing and evenly extracting the bearing. These tools decrease damage and increase the number of applications. Use with 5/8 in. - 18 UNF thread slide hammer.

Part Number	Description	Application
W89326-1	Small Rear Axle Bearing Puller	Fits minimum bearing tube inside diameter of 1 in. and maximum axle tube inside diameter of 1 7/8 in.
W89326-2	Medium Rear Axle Bearing Puller	Fits minimum bearing tube inside diameter of 1 5/16 in. and maximum axle tube inside diameter of 2 3/8 in. including 1987-88 Chevrolet & GMC 8 1/2 in. and 1/2 Ton rear axle bearing
W89326-3	Large Rear Axle Bearing Puller	Fits minimum bearing tube inside diameter of 1 3/8 in. and maximum axle tube inside diameter of 2 7/8 in.

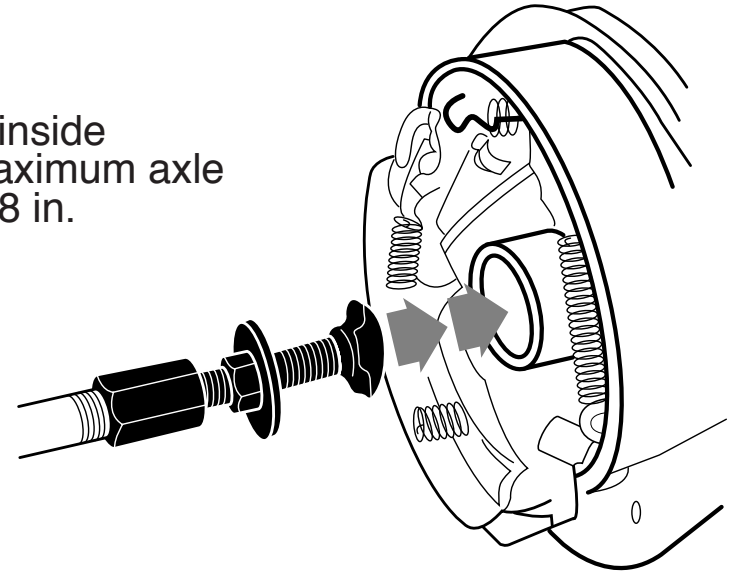

PT
Performance Tool®

Check out the collection of automotive tools we offer.