

Ball Joint & U-Joint Service Set (with 4x4 Adaptors)

To remove ball joint: (see Figure 1)

1. Clean ball joint and control arm to determine if the ball joint is retained by welds. If welds are found, carefully grind away taking care not to damage control arm.
2. Choose proper size press tube, A) 1-3/4"x2", B) 1-3/4"x2-1/2", C) 2-1/4"x3" inside diameter. Tube must fit over body of ball joint.
3. Place C-frame adapter (large hole), (D) over ball joint stud.
4. Place screw adapter (small hole), (E) on screw assembly.
5. Position press tube over body of ball joint and hold in place.
6. Move C-frame into position aligning screw adapter (E) with press tube and C-frame with C-frame adapter (D).
7. Hand tighten, turning screw assembly clockwise while maintaining alignment of C-frame and adapters.
8. Using a 7/8" wrench or socket, continue tightening of screw assembly until ball joint is completely pressed from the control arm.

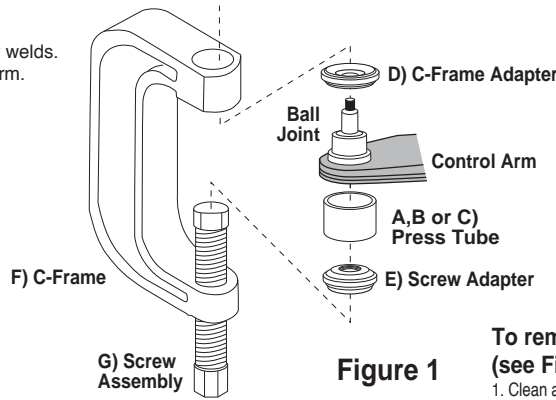

Figure 1

To install ball joint: (see Figure 2)

1. Clean control arm and lubricate ball joint mating surface.
2. Choose proper size press tube, A) 1-3/4"x2", B) 1-3/4"x2-1/2", C) 2-1/4"x3" inside diameter. Tube inside diameter must be slightly larger than control arm hole.
3. Position ball joint into control arm hole making sure it is properly aligned.
4. Place press tube over ball joint stud and position C-frame adapter (large hole), (D) on press tube.
5. Place screw adapter (small hole), (E) on screw assembly.
6. Move C-frame into position aligning screw adapter (E) with ball joint body and C-frame with C-frame adapter (D).
7. Hand tighten, turning screw assembly clockwise while maintaining alignment of C-frame and adapters.
8. Using a 7/8" wrench or socket, continue tightening of screw assembly until ball joint is completely seated in the control arm.

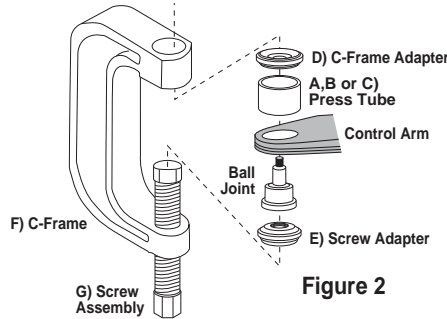

Figure 2

To remove truck brake anchor pin: (see Figure 3)

1. Clean area around pins and remove any pin retainers.
2. Position C-frame (F) over anchor pin and turn screw clockwise to hand tighten while maintaining alignment so that the pin will be pressed through the hole in the C-frame.
3. Using a 7/8" wrench or socket, tighten the screw until the pin is removed.

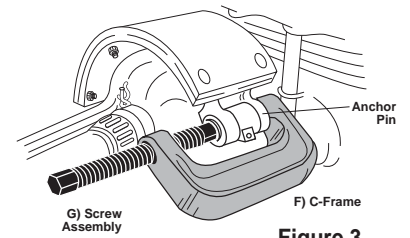

Figure 3

Replacement Parts:

W89304-7	A) Press Tube 1-3/4" x 2"	W89304-5	F) C-Frame
W89304-8	B) Press Tube 1-3/4" x 2-1/2"	W89304-2	G) Screw Assembly
W89304-9	C) Press Tube 2-1/4" x 3"	W89304-10	H) Receiving Cup
W89304-3	D) C-Frame Adapter	W89304-6	J) Receiving Tube
W89304-1	E) Screw Adapter	W89304-4	K) Press Adapter

To install truck brake anchor pin: (see Figure 3)

1. Introduce clean pin into hole in brake assembly.
2. Position C-frame (F) with screw on pin and hole on C-frame over hole on brake shoe.
3. Turn screw clockwise to tighten assembly while maintaining proper alignment.
4. Using a 7/8" wrench or socket tighten screw until the anchor pin is pressed into position.
5. Install pin retainers at this time.

4WD BALL JOINT REMOVAL & INSTALLATION

4WD adapters in this kit are designed for, 1967 & newer 1/2 and 3/4 ton 4WD vehicles with Dana 44 front axle, commonly found on GM, Ford, Jeep, Dodge and IHC.

To remove 4WD ball joint (see Figure 4):

Please Note, lower ball joint must be removed first to allow removal of upper ball joint. Most 4WD ball joints press in and out from the stud side.

1. Clean lower ball joint and surrounding area.
2. Remove lower ball joint snap ring.
3. Place receiving tube (J) over stud of lower ball joint. Tube should be slightly larger than the diameter of the ball joint.
4. Move C-frame into position aligning top of C-frame with receiving tube (J) and screw assembly (G) with the bottom of the ball joint.
5. Hand tighten, turning screw assembly (G) clockwise while maintaining alignment of C-frame.
6. Using a 7/8" wrench or socket, continue tightening of screw assembly until ball joint is completely pressed free.
7. To remove the upper ball joint, repeat the process with screw assembly protruding through lower ball joint hole.

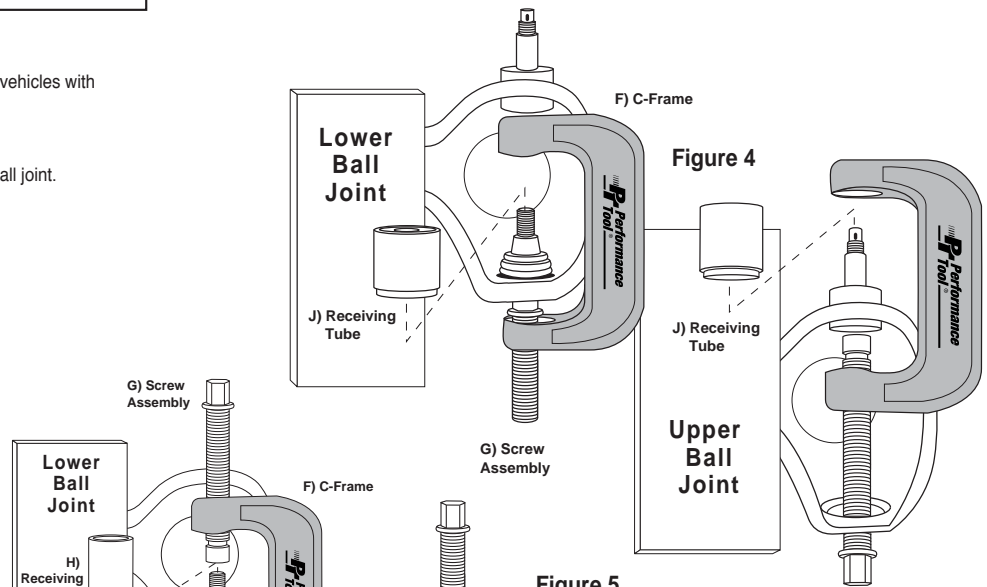

Figure 5

To install 4WD ball joint (see Figure 5):

Please Note, lower ball joint must be installed first to allow installation of upper ball joint.

1. Clean and lubricate the holes that the ball joints will be pressed into.
2. Position new ball joint into hole and place the press adapter (K) over the stud side of the ball joint.
3. Move C-frame into position by inserting hex end of screw assembly (G) into upper ball joint hole and then inserting the plug end of the screw assembly into press adapter (K).
4. Position receiving cup (H) between ball joint hole and end of C-frame.
5. Hand tighten, turning screw assembly (G) clockwise while maintaining alignment of C-frame.
6. Using a 7/8" wrench or socket, continue tightening assembly until the ball joint is completely seated into position.
7. Install the ball joint snap ring.
8. Repeat the process for the upper ball joint.



Replacement Parts:

W89304-7	A) Press Tube 1-3/4" x 2"
W89304-8	B) Press Tube 1-3/4" x 2-1/2"
W89304-9	C) Press Tube 2-1/4" x 3"
W89304-3	D) C-Frame Adapter
W89304-1	E) Screw Adapter
W89304-5	F) C-Frame
W89304-2	G) Screw Assembly
W89304-10	H) Receiving Cup
W89304-6	J) Receiving Tube
W89304-4	K) Press Adapter