



**CHEVY SILVERADO/TAHOE  
GMC SIERRA/YUKON**

**1500 SERIES**

**2" - 2.25" LEVELING KIT**

**INSTALLATION INSTRUCTIONS  
2007-2016 KIT# CL230PA**

**⚠ WARNING**  
Installation of a Performance Automotive Group suspension lift kit will change the vehicle's center of gravity and handling characteristics both on- and off-road. You must drive the vehicle safely! Extreme care must be taken to prevent vehicle rollover or loss of control, which could result in serious injury or death. Avoid sudden sharp turns or abrupt maneuvers and always make sure all vehicle occupants have their seat belts fastened.

**⚠ WARNING**  
Before you install this kit, read and understand all instructions, warnings, cautions, and notes in this instruction sheet and in the vehicle owner's manual.

**⚠ CAUTION**  
Proper installation of this kit requires knowledge of the factory recommended procedures for removal and installation of original equipment components. We recommend that the factory shop manual and any special tools needed to service your vehicle be on hand during the installation. Installation of this kit without proper knowledge of the factory recommended procedures may affect the performance of these components and the safety of the vehicle. We strongly recommend that a certified mechanic familiar with the installation of similar components install this kit.

**⚠ WARNING**  
This kit should only be installed on a vehicle that is in good working condition. Before you install the kit, thoroughly inspect the vehicle for corrosion or deformation of the sheet metal. If the vehicle is suspected to have been in a collision or misused, do not install this kit. Off-road use of your vehicle with this kit installed may increase the stress applied to the factory components. Failure to observe this warning may result in serious personal injury and/or severe damage to your vehicle.

**⚠ WARNING**  
Many states and municipalities have laws restricting bumper heights and vehicle lifts. Consult state and local laws to determine if the changes you intend to make to the vehicle comply with the law.

**⚠ WARNING**  
The installation of larger wheels/tires may reduce the effectiveness of the braking system.

**⚠ WARNING**  
Always wear eye protection when operating power tools.

**⚠ WARNING**  
Before you install this kit, block the vehicle tires to prevent the vehicle from rolling.

**NOTE**  
Performance Automotive Group recommends using the Loctite® supplied in the kit on the threads of all kit nuts and bolts unless specified otherwise in these instructions.

**NOTE**  
Installation of a suspension lift will change the drive-line angles which may cause a noticeable vibration in the vehicle. See the troubleshooting section at the end of these instructions if this occurs.

# Before Starting Installation

**NOTE**  
Kit parts are prefaced by the word *kit* and appear in bold print.

1. Carefully read all warnings and instructions completely before beginning.
2. Verify all parts have been received in this kit by checking the parts list at the end of this document.
3. **Only install this kit on the vehicle for which it is specified.** If anytime during the installation you encounter something different from what is outlined in the instructions
4. Park vehicle on a clean, dry, flat, level surface and block tires so vehicle cannot roll in either direction.

**NOTE**  
Adhere to recommendations when replacement fasteners, retainers and keepers are called out in the factory service manual. When re-assembling the vehicle it is recommended by the vehicle manufacturer that certain fasteners are replaced in order to maintain proper retention characteristics. This system may not include all replacement hardware as recommended by the factory service manual. Additional replacement hardware should be obtained prior to installation of this system to meet the requirements of the factory service manual.

# Torque Specifications

See factory service manual for torque values when re-using OE fasteners.

<b>Bolt Size</b>	<b>Grade 5 (ft.-lbs.)</b>	<b>Grade 8 (ft.-lbs.)</b>
1/4"-20	10	10
1/4"-28	10	12.5
5/16"-18	17	22.5
5/16"-24	20	25
3/8"-16	30	40
3/8"-24	35	45
7/16"-14	50	65
7/16"-20	55	70
1/2"-13	75	100
1/2"-20	55	70
9/16"-12	105	135
9/16"-18	115	150
5/8"-11	150	195
5/8"-18	160	210
3/4"-16	175	225

# Engine Compartment

1. Disconnect both battery cables. Disconnect negative cable first, then positive cable.

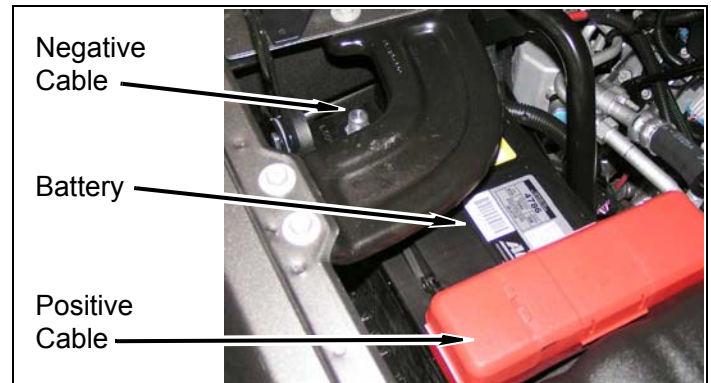

# Prepare to Install Front Leveling Kit

1. Loosen, but do not remove, lug nuts on each front wheel.
2. Using a hydraulic floor jack, slowly lift front axle until front tires are 3-5" off ground. Position jack stands under frame. Lower vehicle onto jack stands while

maintaining hydraulic jack pressure underneath front axle.

**⚠ WARNING**

Use extreme caution when lifting vehicle from ground. To prevent serious personal injury, ensure the lifting device is securely placed.

3. Remove lug nuts and front wheels from vehicle.
4. Remove two nuts, washers, bushings, two bolts, and two end links from sway bar and two lower control arms.

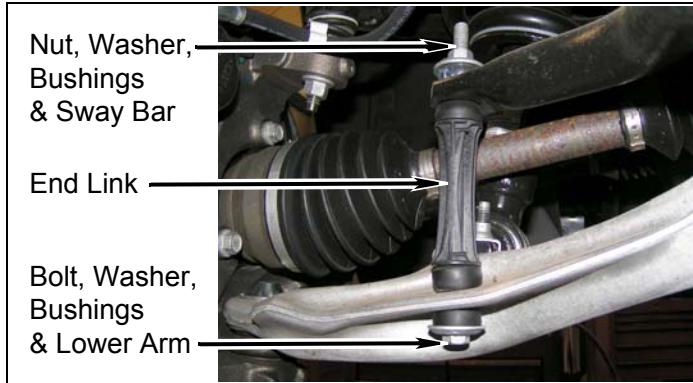

5. Driver side coil-over

- a. Support lower control arm with hydraulic floor jack.
- b. Remove wiring harnesses, clips, three nuts and coil-over from upper perch.

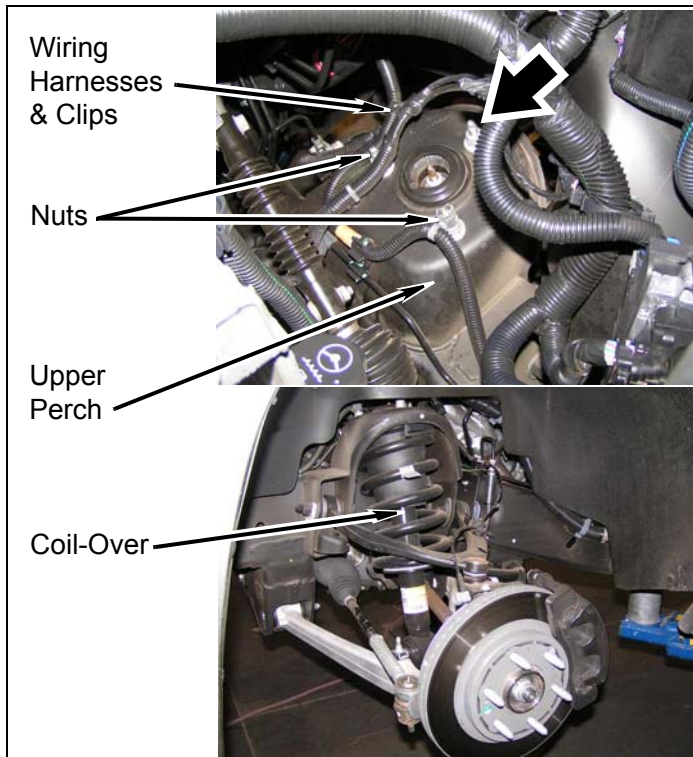

- c. Remove two lower coil-over bolts from lower control arm.

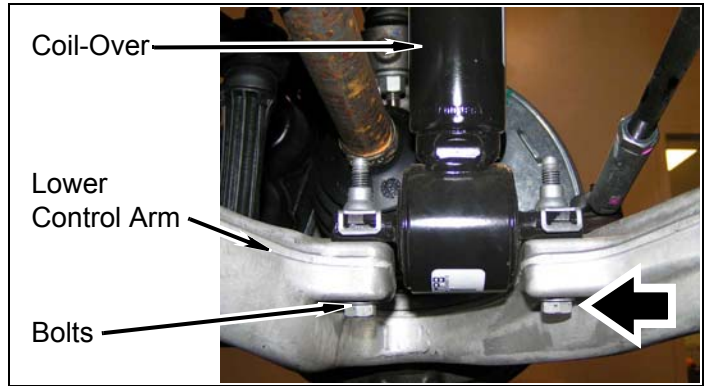

- d. Loosen upper control arm nut from ball joint and free ball joint from steering knuckle. Do not completely remove upper ball joint or nut from steering knuckle and ball joint.

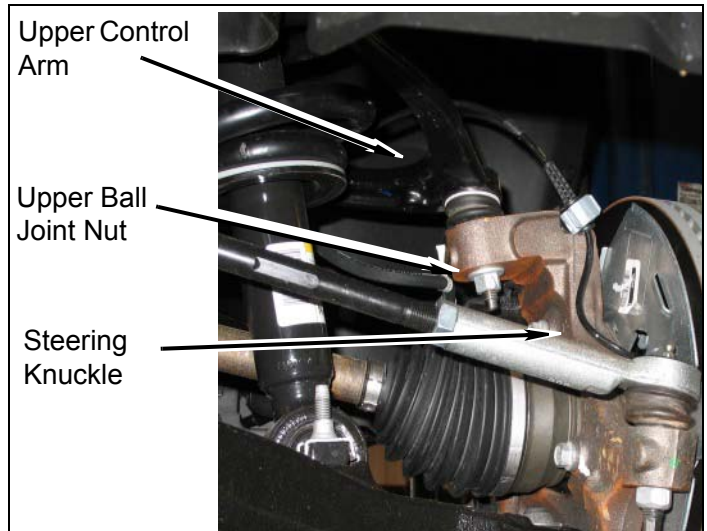

- e. Remove coil-over from vehicle.
- f. Repeat above steps for passenger side coil-over.

## Install Front Leveling Kit

1. Driver side coil-over

a. Install **kit spacer** (upper) onto upper plate.

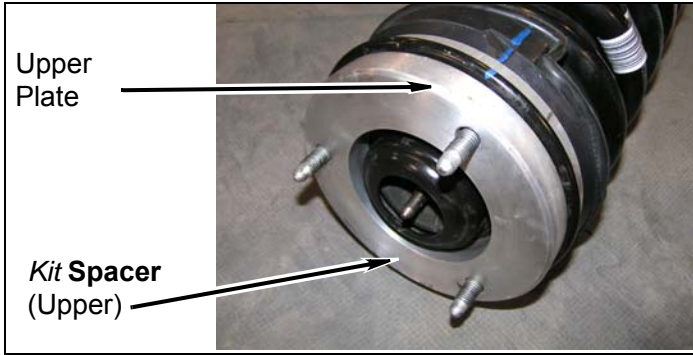

b. From **CL230BAG**: Install coil-over onto upper perch with three **kit washers** (10mm) and three **kit nuts** (10mm stover) and **kit Loctite®**. TORQUE to OE specification.

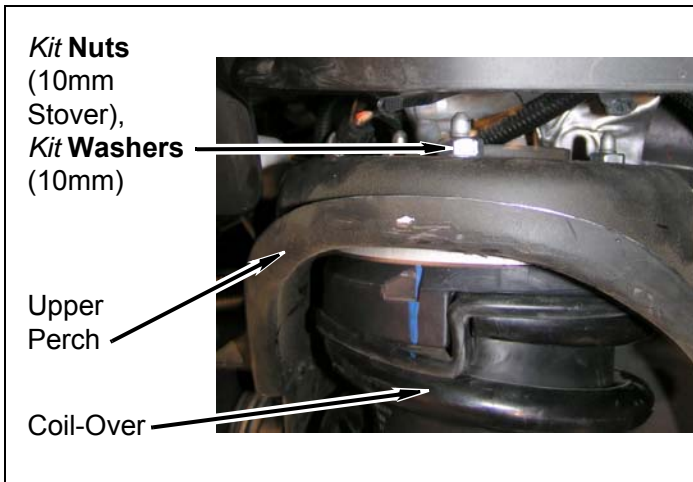

c. Install coil-over onto lower control arm with **kit spacer** (Lower) in between coil-over and lower control arm with two **kit bolts** (10mm) and **kit Loctite®**. TORQUE to OE specification.

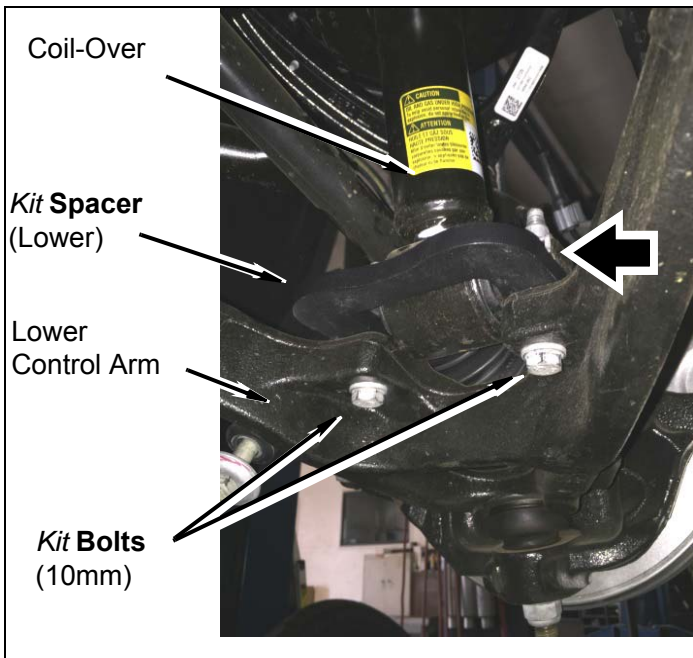

d. Tighten upper control arm ball joint nut to steering knuckle. TORQUE to OE specification

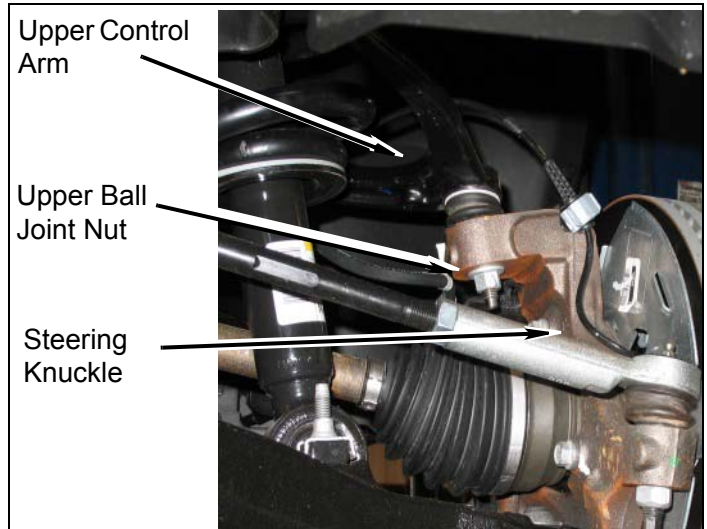

e. Repeat above steps for passenger side coil-over.

2. Install sway bar onto two lower control arms with two end links, bushings, two bolts, washers, and two nuts.

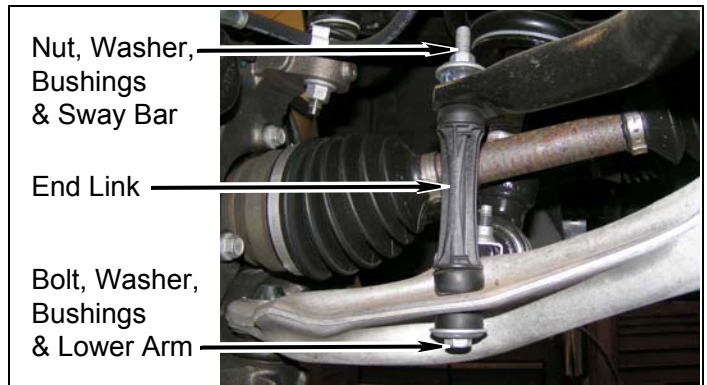

**CAUTION**  
DO NOT OVER-TIGHTEN nut or OVER-COMPRESS sway bar end link bushings. Damage may occur to bushings if over-compressed.

3. Install front wheels onto vehicle with lug nuts. Snug, but DO NOT TORQUE lug nuts.
4. Using hydraulic floor jack, raise front of vehicle and remove jack stands.
5. Lower front of vehicle onto ground.
6. TORQUE lug nuts to specification.

# After Completing Installation

## Engine Compartment

1. Connect both battery cables. Connect positive cable first, then negative cable.

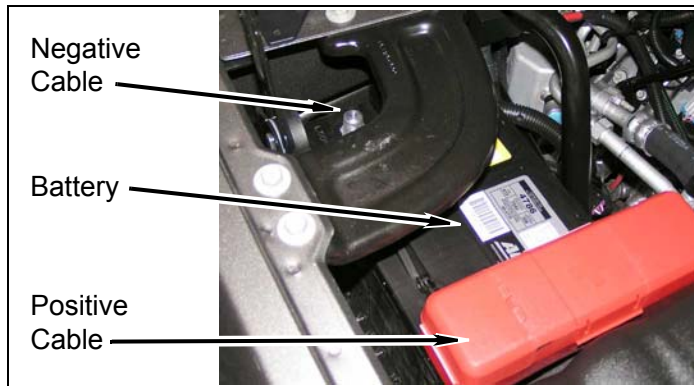

## Miscellaneous

1. Apply **kit label** (warning) onto dashboard in plain sight of all vehicle occupants.
2. Adjust headlights.
3. Check all fasteners to ensure they are tight.
4. Ensure all wires, hoses, cables, etc. are properly connected and there is ample slack.
5. Align vehicle to OE specifications. Retain alignment results.

## Dynamic Vehicle Check

1. Check steering and suspension in all positions to ensure that there is no bind and adequate clearance between all moving, fixed, and heated members. Check operation of clutch, brake system, and parking brake. Check operation of transmission and transfer case. Ensure there is full engagement in all gears and 4WD ranges. Check battery connections and electrical component operations. Test-drive vehicle.

### ⚠ CAUTION

Performance Automotive Group does not recommend any particular wheel and tire combinations for use with its suspension lifts and cannot assume responsibility for the customer's choice of wheels and tires. Refer to your owner's manual for recommended tire sizes and warnings related to the use of oversized tires. Larger wheel and tire combinations increase stress and wear on steering and suspension components, which leads to increased maintenance and higher risk for component failure. Larger wheel and tire combinations also alter speedometer calibration, braking effectiveness, center of gravity, and handling characteristics. Consult an experienced local off road shop to find what wheel and tire combinations work best with your vehicle.

### NOTE

All warranty information, instruction sheets, and other documents regarding the installation of this product must be retained by the vehicle owner. Information contained in the instructions and on the warranty card will be required for any warranty claims. The vehicle owner needs to understand the modifications made to the vehicle and how they affect vehicle handling and performance. Failure to provide the customer with this information can result in damage to the vehicle and severe personal injury.

## Kit Parts List

### Qty. Description

1	<b>Instruction sheet</b>
1	<b>Label</b> (logo)
1	<b>Label</b> (warning)
1	<b>Loctite®</b> (6ml bottle)
2	<b>Spacer</b> (Upper)
2	<b>Spacer</b> (Lower)

<b>1</b>	<b><u>CL230PABAG (Hardware Bag Kit)</u></b>
4	<b>Bolt</b> (10mm x 70mm)
6	<b>Nut</b> (10mm)
10	<b>Washer</b> (10mm)

### ⚠ WARNING

Retorque all fasteners after 500 miles and after off road use. All suspension lift components should be visually inspected and fasteners retorqued during routine vehicle servicing.