



FORD BRONCO II / RANGER BODY LIFT KIT INSTALLATION INSTRUCTIONS

2" Lift

1983-88 Ranger	742
1989-92 Ranger	832
1984-88 Bronco II	752
1989-90 Bronco II	70002

3" Lift

1983-88 Ranger	743
1989-92 Ranger	833
1984-88 Bronco II	753
1989-90 Bronco II	70003

⚠ WARNING

Installation of a Performance Automotive Group body lift kit will change the vehicle's center of gravity and handling characteristics both on- and off-road. You must drive the vehicle safely! Extreme care must be taken to prevent vehicle rollover or loss of control, which could result in serious injury or death. Avoid sudden sharp turns or abrupt maneuvers and always make sure all vehicle occupants have their seat belts fastened.

⚠ WARNING

Before you install this kit, read and understand all instructions, warnings, cautions, and notes in this instruction sheet and in the vehicle owner's manual.

⚠ CAUTION

Proper installation of this kit requires knowledge of the factory recommended procedures for removal and installation of original equipment components. We recommend that the factory shop manual and any special tools needed to service your vehicle be on hand during the installation. Installation of this kit without proper knowledge of the factory recommended procedures may affect the performance of these components and the safety of the vehicle. We strongly recommend that a certified mechanic familiar with the installation of similar components install this kit.

⚠ WARNING

This kit should only be installed on a vehicle that is in good working condition. Before you install the kit, thoroughly inspect the vehicle for corrosion or deformation of the sheet metal around the factory body mounts. If the vehicle is suspected to have been in a collision or misused, do not install this kit. Off-road use of your vehicle with this kit installed may increase the stress applied to the factory body mounts. We do not recommend that any vehicle with a body lift kit installed be involved in any extreme off-road maneuvers such as jumping. Failure to observe this warning may result in serious personal injury and/or severe damage to your vehicle.

⚠ WARNING

Many states and municipalities have laws restricting bumper heights and vehicle lifts. Consult state and local laws to determine if the changes you intend to make to the vehicle comply with the law. Before combining a body lift with a suspension lift, consult an installation professional to see how this will affect the vehicle.

⚠ WARNING

The installation of larger tires may reduce the effectiveness of the Braking System.

⚠ WARNING

Always wear eye protection when operating power tools.

⚠ WARNING

Before you install this kit, block the vehicle tires to prevent the vehicle from rolling.

⚠ WARNING

Accidental deployment of the air bag can result in serious personal injury or death. To avoid accidental deployment during installation of the kit, the Supplemental Restraint System (SRS, or airbag) must remain deactivated. Do not allow anyone near the airbag during installation. Refer to the factory service manual or owner's manual for the recommended procedure to disable the SRS. After you install the kit, reactivate the SRS before driving the vehicle.

⚠ NOTE

Performance Automotive Group recommends using the Loctite® supplied in the kit on the threads of all kit nuts and bolts unless specified otherwise in these instructions.

Before Starting Installation

⚠ NOTE
This kit does not fit vehicles with diesel engines.

⚠ NOTE
This kit does not include rear bumper brackets and they are NOT available from Performance Automotive Group.

⚠ NOTE
On vehicles with inline-6 or V6 engine, the lower radiator hose must be replaced with an aftermarket moldable hose to prevent it from contacting the smog pump.

⚠ NOTE
Kit parts are prefaced by the word kit and appear in **bold** print.

1. Carefully read all warnings and instructions completely before beginning.
2. Verify all parts have been received in this kit by checking the parts list at the end of this document.

⚠ NOTE
If parts are missing from kit, please be prepared to provide the following information:
1. **Name** of purchase location
2. **Bar Code** on side of box
3. **Date** above bar code
4. **Date** inside box cover
5. **Inspector #** from inside box cover

3. **Only install this kit on the vehicle for which it is specified.**
4. Special tools needed:
 - a. Die grinder or similar tool capable of cutting metal.
5. Park vehicle on a clean, dry, flat, level surface and block tires so vehicle cannot roll in either direction.

Battery cables

1. Disconnect both battery cables. Disconnect negative cable first, then positive cable.

Airbag fuse

1. If vehicle is equipped with an air bag, remove airbag fuse. Check owner's manual for fuse location.

Measurements

1. Measure and record distance between front bumper and fenders.
Driver Side _____ Passenger Side _____
2. Measure and record distance between rear bumper and bed
Driver Side _____ Passenger Side _____
3. Measure and record distance between cab and bed.
Driver Side _____ Passenger Side _____

Prepare to Install Kit

Engine Compartment

1. Fan and Fan shroud
 - a. Remove hardware securing fan and fan shroud.
 - b. Remove fan and fan shroud.
2. Steering shaft

⚠ WARNING
Some vehicles may be equipped with Supplemental Restraint System (SRS, or airbag). Accidental deployment of the airbag can result in serious personal injury or death. To avoid accidental deployment, the SRS must remain deactivated during installation of this kit. Do not allow anyone near the airbag during installation. Refer to the factory service manual or owner's manual for the recommended procedure to disable the SRS. After kit installation, the SRS must be reactivated before driving the vehicle.

⚠ CAUTION
If the following step is not performed, the airbag clockspring could be damaged. Do not turn the steering wheel while the steering shaft is disconnected.

- a. Strap steering wheel to prevent accidental movement.
- b. Mark position of upper steering shaft with relation to steering coupler.
- c. Remove factory set bolt from upper steering shaft.

Front of Vehicle

1. Front bumper
 - a. Remove front bumper.

Underside of Vehicle

1. Automatic transmission
 - a. Transmission is shifted via a cable. Check cable to ensure enough slack is available. No modification should be necessary.

2. Manual transmission
 - a. Shift lever should simply drop down into the floor. It may be necessary to notch floor after lifting cab (as specified later in this document).
3. Brake cable bracket
 - a. Remove brake cable bracket located on frame below driver side of vehicle. Bracket will be relocated (as specified later in this document).
4. Fuel filler

⚠ WARNING
Use extreme caution when working near the fuel lines and the fuel tank. Clean up spilled fuel immediately. A spark could cause an explosion or fire resulting in serious personal injury and property damage.

- a. Check fuel filler hose for ample flex and reach. Disconnect if necessary.

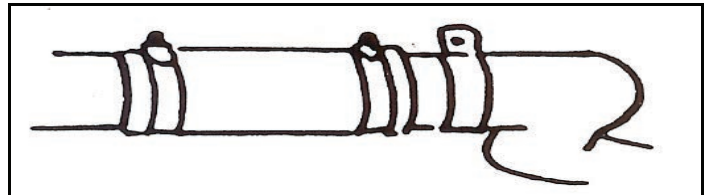

5. Fuel tank

NOTE:
If vehicle is equipped with a fuel tank located behind the front seat, it may have to be removed in order to gain access to the rear cab body mount bolts.

- a. Remove fuel tank from behind seat (if equipped) to gain access to rear cab body mounts.

Install Kit

Cab

1. Prepare to lift cab from frame.
 - a. Remove kick panels and door jamb scuff plates. Pull carpet back to reveal access covers above cab mount bolts. Remove access covers.

- b. Loosen, but DO NOT REMOVE, cab mounting bolts on driver side.

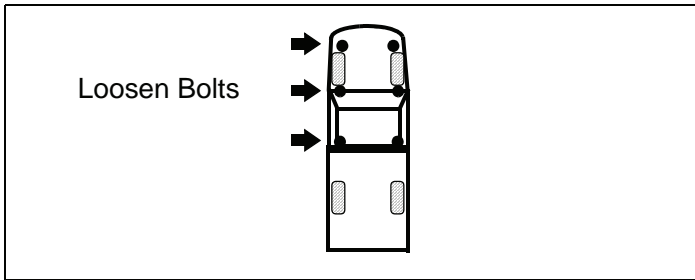

- c. Remove cab mounting bolts from passenger side only.

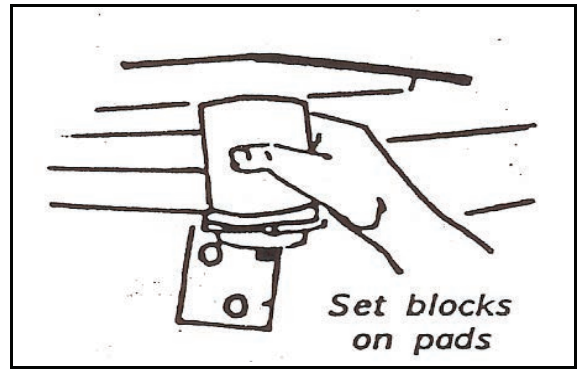
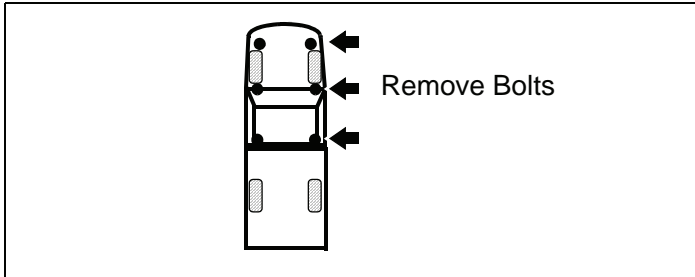

- b. Place *kit block* on top of bushing at each mount. Install *kit bolts* and *kit washers* as shown. DO NOT TIGHTEN at this time.

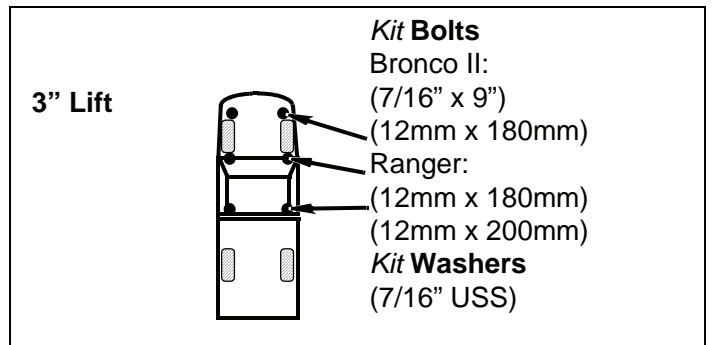
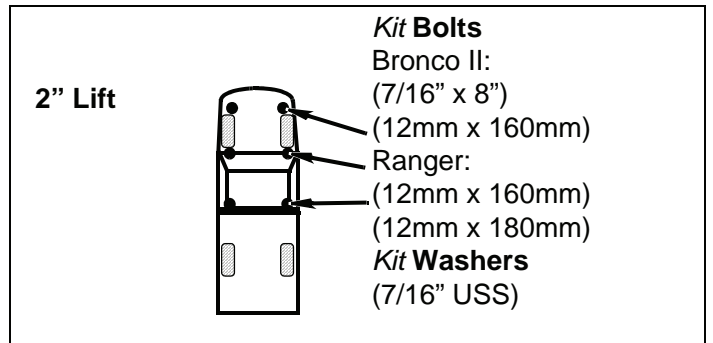

- c. Lower cab onto *kit blocks*.
3. Lift driver side of cab.
- Repeat previous steps for driver side of cab.
 - Set position of cab in relation to bed according to measurements recorded earlier.
 - Remove each *kit bolt* one at a time, apply *kit Loctite®* to threads, and install *kit bolt* with *kit washer*. Tighten *kit bolts* to manufacturer's specification.
 - Install access hole covers on floor. Lay carpet back to its original position. Install kick panels and door jamb scuff plates.

⚠ WARNING

Use extreme caution when lifting body from frame. To prevent serious personal injury, ensure the lifting device is securely placed. Keep your hands out from between the body and frame.

⚠ CAUTION

Continually check hoses, wires, lines, etc. to be sure that everything is flexing properly and not binding, or damage to the vehicle could result. Be especially careful of the A/C hoses at the firewall, the belt pulley, the core support and the fuel tank neck (if equipped with fuel tank behind seat.). Ensure brake lines stretch while lifting. Bending the lines to gain ample slack may be necessary. Be extremely careful not to kink the lines.

2. Lift passenger side of cab.

- Using a hydraulic jack and a wooden block, slowly raise passenger side of cab just high enough to remove front body mount bushing near radiator.

⚠ WARNING

The *kit blocks* must be installed in addition to the factory bushings. Installing the *kit blocks* without the factory bushings could result in damage to the vehicle or serious personal injury.

Bed

1. Prepare to lift bed from frame.

- a. Loosen, but **DO NOT REMOVE**, bed mounting bolts on driver side.

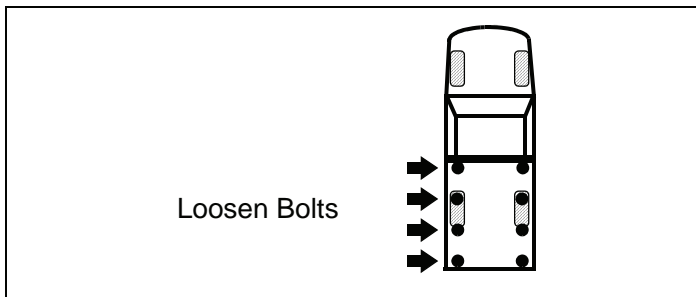

- b. Remove bed mounting bolts from passenger side only.

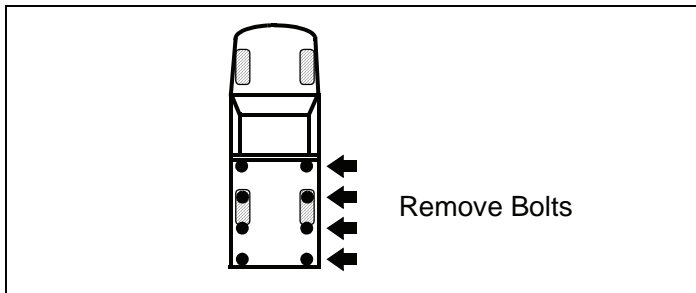

- b. At each mount, install a *kit bolt*, *kit washer* (7/16" USS), and *kit nut* (1/2" nylock). **DO NOT TIGHTEN** at this time.

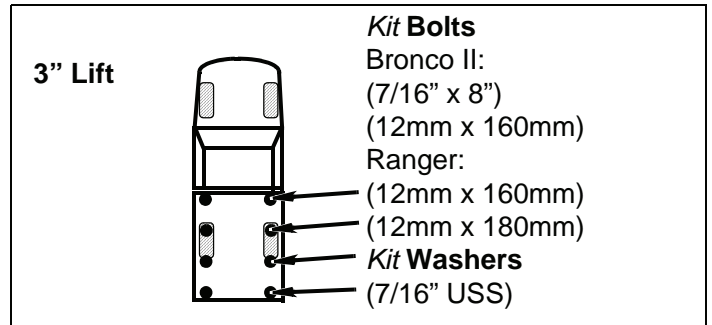
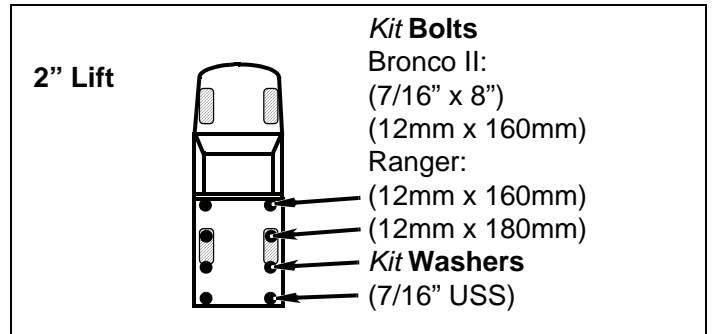

- c. Lower cab onto the *kit blocks*.

3. Lift driver side of bed.

- a. Repeat previous steps for driver side of cab.
- b. Set position of cab in relation to bed according to measurements recorded earlier.
- c. Remove each *kit bolt* one at a time, apply *kit Loctite*® to threads, install, and tighten to manufacturer's specification.

Fuel filler

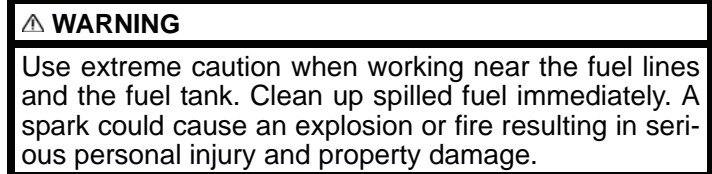

1. If fuel filler hose was disconnected, reconnect and adjust as necessary.

WARNING

Use extreme caution when lifting the bed from the frame. To prevent serious personal injury, ensure the lifting device is securely placed. Keep your hands out from between the bed and frame.

CAUTION

To prevent damage to the vehicle while lifting the bed, continually check hoses, wires, brake lines, etc. to ensure everything is flexing properly and not binding. Ensure clearance between bed and cab is maintained.

2. Lift passenger side of bed.

- a. Slowly raise passenger side of bed and place a *kit block* on frame at each mount. **DO NOT RAISE** bed any more than necessary.

Steering shaft (1983-88)

1. Install *kit steering extension* into upper steering shaft.
 - a. Align threaded hole in *kit steering extension* to hole in upper steering shaft (for stock steering shaft bolt).
 - b. Apply *kit Loctite*® to threads of stock steering shaft bolt. Install bolt, ensuring it goes through relief slot on *kit steering extension*. This will prevent the *kit steering extension* from coming out of the "U"-joint. Tighten bolt to manufacturer's specification.
 - c. Install *kit steering extension* onto steering shaft.
 - d. Apply *kit Loctite*® to threads of *kit bolt* (1/4"-20 x 1"). Install *kit bolt* in *kit steering extension*, ensuring it goes through relief slot on steering shaft. This will prevent the steering shaft from coming out of the *kit steering extension*. Tighten *kit bolt* to 33 ft. lbs.
 - e. Install lower steering shaft coupler around *kit steering extension*. Apply *kit Loctite*® to threads of stock steering bolt and nut.
 - f. Install factory bolt through stock holes in coupler and install nut on factory bolt. Tighten factory bolt to manufacturer's specification.



Steering shaft (1989-92)

1. Install *kit steering extension* into upper steering shaft.

- a. Align hole in *kit steering extension* to hole in upper steering shaft.
- b. Install *kit bolt* (3/8"-16 x 1-1/2") with *kit washer* (3/8" USS) through upper hole in *kit steering extension*. Install *kit washer* (3/8" USS) and *kit nut* (3/8"-16 Nylock) onto *kit bolt*, but DO NOT TIGHTEN.
- c. Install lower steering shaft coupler around *kit steering extension*. Apply *kit Loctite*® to threads of stock steering bolt and nut.
- d. Install factory bolt through stock holes in coupler and install nut on factory bolt. Tighten *kit bolt* (3/8"-16 x 1-1/2"). Tighten factory bolt to manufacturer's specification.

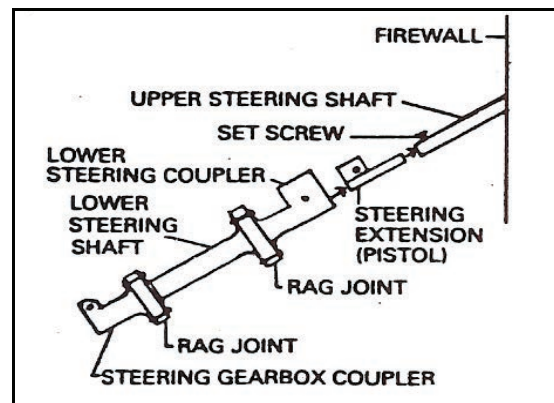

NOTE:

If steering binds during operation, perform the following procedures:

1. Locate mounting flange for steering column under dashboard.
2. Unbolt flange from firewall.
3. Drill out holes in top of flange as far as possible.
4. Pull steering column down as far as possible.
5. Install factory bolts and tighten.

Transmission shift linkage

1. If transmission cannot be shifted into all gears, remove shift boot. Check shift operation again.
 - a. Make a note of where shift lever contacts floor. Cut 1" piece from front and back of boot bracket according to diagram below.

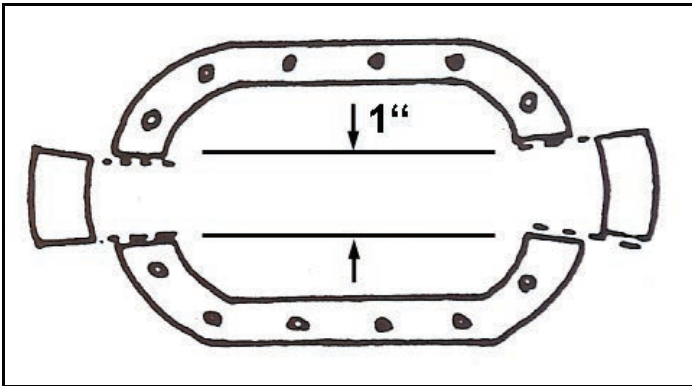

NOTE:

Shift lever may need to be bent slightly toward driver side of vehicle.

Brake cable bracket

1. Relocate brake cable bracket 1-1/2" higher on frame.

Fan and Fan shroud

1. Cut bottom of fan shroud to clear fan.

2. Install fan and fan shroud.

NOTE:

Structural member below radiator does not allow radiator to be lowered. Fan may blow below center of radiator. This should not affect engine performance while driving. Overheating may occur if vehicle sits idling for extended periods of time.

Front bumper

1. Install front bumper.

After Completing Installation

Airbag fuse

1. Install airbag fuse (if equipped).

Battery cables

1. Connect both battery cables. Connect positive cable first, then negative cable.

Miscellaneous

1. Apply **kit label** (warning) to dashboard in plain sight of all vehicle occupants.
2. Check all fasteners to ensure they are tight.
3. Adjust the headlights.
4. Ensure all wires, hoses, cables, etc. are properly connected and there is ample slack.

Dynamic Vehicle Check

1. Test-drive vehicle. Check steering in both directions to ensure that there is no bind. Check operation of clutch, brake system, and parking brake. Check operation of transmission and transfer case. Ensure there is full engagement in all gears and 4WD ranges. Check battery connections and electrical component operations.

⚠CAUTION

Performance Automotive Group does not recommend any particular wheel and tire combinations for use with its body lifts and cannot assume responsibility for the customer's choice of wheels and tires. Refer to your owner's manual for recommended tire sizes and warnings related to the use of oversized tires. Larger wheel and tire combinations increase stress and wear on steering and suspension components, which leads to increased maintenance and higher risk for component failure. Larger wheel and tire combinations also alter speedometer calibration, braking effectiveness, center of gravity, and handling characteristics. Consult an experienced local off road shop to find what wheel and tire combinations work best with your vehicle.

⚠NOTE

All warranty information, instruction sheets, and other documents regarding the installation of this product must be retained by the vehicle owner. Information contained in the instructions and on the warranty card will be required for any warranty claims. The vehicle owner needs to understand the modifications made to the vehicle and how they affect vehicle handling and performance. Failure to provide the customer with this information can result in damage to the vehicle and severe personal injury.

⚠ NOTE

Depending on the vehicle configuration (automatic or manual transmission, 2WD or 4WD, cab length, bed length, etc.), some parts may not be used.

⚠WARNING

Retorque all fasteners after 500 miles and after off road use. All body lift components should be visually inspected and fasteners retorqued during routine vehicle servicing.

Parts List

Qty Description

2" Lift

Kit 742

14	Block, 2" Lift
12	Bolt, 12mm-1.75 x 160mm
2	Bolt, 12mm-1.75 x 180mm
1	Bolt, 1/4"-20 x 1"
1	Label, Logo
1	Label, Warning
1	Loctite®
1	Steering Extension
14	Washer, 7/16" USS
1	Instruction set

Kit 832

14	Block, 2" Lift
12	Bolt, 12mm-1.75 x 160mm
2	Bolt, 12mm-1.75 x 180mm
1	Bolt, 3/8"-16 x 1-1/2"
1	Label, Logo
1	Label, Warning
1	Loctite®
1	Nut, 3/8"-16 Nylock
1	Steering Extension
14	Washer, 7/16" USS
2	Washer, 3/8" USS
1	Instruction set

Kit 752

10	Block, 2" Lift
8	Bolt, 12mm-1.75 x 160mm
2	Bolt, 7/16"-14 x 8"
1	Bolt, 1/4"-20 x 1"
1	Label, Logo
1	Label, Warning
1	Loctite®
1	Steering Extension
10	Washer, 7/16" USS
1	Instruction set

Kit 70002

10	Block, 2" Lift
8	Bolt, 12mm-1.75 x 160mm
2	Bolt, 7/16"-14 x 8"
1	Bolt, 3/8"-16 x 1-1/2"
1	Label, Logo
1	Label, Warning
1	Loctite®
1	Nut, 3/8"-16 Nylock
1	Steering Extension
10	Washer, 7/16" USS
2	Washer, 3/8" USS
1	Instruction set

3" Lift

Kit 743

14	Block, 3" Lift
12	Bolt, 12mm-1.75 x 180mm
2	Bolt, 12mm-1.75 x 200mm
1	Bolt, 1/4"-20 x 1"
1	Label, Logo
1	Label, Warning
1	Loctite®
1	Steering Extension
14	Washer, 7/16" USS
1	Instruction set

Kit 833

14	Block, 3" Lift
12	Bolt, 12mm-1.75 x 180mm
2	Bolt, 12mm-1.75 x 200mm
1	Bolt, 3/8"-16 x 1-1/2"
1	Label, Logo
1	Label, Warning
1	Loctite®
1	Nut, 3/8"-16 Nylock
1	Steering Extension
14	Washer, 7/16" USS
2	Washer, 3/8" USS
1	Instruction set

Kit 753

10	Block, 3" Lift
8	Bolt, 12mm-1.75 x 180mm
2	Bolt, 7/16"-14 x 9"
1	Bolt, 1/4"-20 x 1"
1	Label, Logo
1	Label, Warning
1	Loctite®
1	Steering Extension
10	Washer, 7/16" USS
1	Instruction set

Kit 70003

10	Block, 3" Lift
8	Bolt, 12mm-1.75 x 180mm
2	Bolt, 7/16"-14 x 9"
1	Bolt, 3/8"-16 x 1-1/2"
1	Label, Logo
1	Label, Warning
1	Loctite®
1	Nut, 3/8"-16 Nylock
1	Steering Extension
10	Washer, 7/16" USS
2	Washer, 3/8" USS
1	Instruction set

Ford Ranger/Bronco II 2"/3" Body Lift Kit