



**FORD RANGER/SPLASH  
MAZDA B-SERIES  
(2&4WD, STANDARD & EXT. CAB)  
3" BODY LIFT KIT  
INSTALLATION INSTRUCTIONS  
1995-1997 KIT# 853**

**⚠ WARNING**

Installation of a Performance Automotive Group body lift kit will change the vehicle's center of gravity and handling characteristics both on- and off-road. You must drive the vehicle safely! Extreme care must be taken to prevent vehicle rollover or loss of control, which could result in serious injury or death. Avoid sudden sharp turns or abrupt maneuvers and always make sure all vehicle occupants have their seat belts fastened.

**⚠ WARNING**

Before you install this kit, read and understand all instructions, warnings, cautions, and notes in this instruction sheet and in the vehicle owner's manual.

**⚠ CAUTION**

Proper installation of this kit requires knowledge of the factory recommended procedures for removal and installation of original equipment components. We recommend that the factory shop manual and any special tools needed to service your vehicle be on hand during the installation. Installation of this kit without proper knowledge of the factory recommended procedures may affect the performance of these components and the safety of the vehicle. We strongly recommend that a certified mechanic familiar with the installation of similar components install this kit.

**⚠ WARNING**

DO NOT combine suspension, body, or other lift devices. Use of vehicle with combined lifts may result in unsafe and/or unexpected handling characteristics.

**⚠ WARNING**

This kit should only be installed on a vehicle that is in good working condition. Before you install the kit, thoroughly inspect the vehicle for corrosion or deformation of the sheet metal around the factory body mounts. If the vehicle is suspected to have been in a collision or misused, do not install this kit. Off-road use of your vehicle with this kit installed may increase the stress applied to the factory body mounts. We do not recommend that any vehicle with a body lift kit installed be involved in any extreme off-road maneuvers such as jumping. Failure to observe this warning may result in serious personal injury and/or severe damage to your vehicle.

**⚠ WARNING**

Many states and municipalities have laws restricting bumper heights and vehicle lifts. Consult state and local laws to determine if the changes you intend to make to the vehicle comply with the law.

**⚠ WARNING**

The installation of larger tires may reduce the effectiveness of the braking system.

**⚠ WARNING**

Always wear eye protection when operating power tools.

**⚠ WARNING**

Before you install this kit, block the vehicle tires to prevent the vehicle from rolling.

**⚠ WARNING**

Accidental deployment of the air bag can result in serious personal injury or death. To avoid accidental deployment during installation of the kit, the Supplemental Restraint System (SRS, or airbag) must remain deactivated. Do not allow anyone near the airbag during installation. Refer to the factory service manual or owner's manual for the recommended procedure to disable the SRS. After you install the kit, reactivate the SRS before driving the vehicle.

**NOTE**

Performance Automotive Group recommends using the Loctite® supplied in the kit on the threads of all kit nuts and bolts unless specified otherwise in these instructions.

# Before Starting Installation

## NOTE

Kit parts are prefaced by the word *kit* and appear in **bold** print.

1. Carefully read all warnings and instructions completely before beginning.
2. Verify all parts have been received in this kit by checking the parts list at the end of this document.

## NOTE

If parts are missing from kit, please be prepared to provide the following information:

1. **Name** of purchase location
2. **Bar Code** on side of box
3. **Date** above bar code
4. **Date** inside box cover
5. **Inspector #** from inside box cover

3. **Only install this kit on the vehicle for which it is specified.** If anytime during the installation you encounter something different from what is outlined in the instructions, call technical support.

4. Special tools needed:

- a. Welder or access to a professional welding shop.
- b. Die grinder or similar tool capable of cutting metal.
- c. T55 Torx bit or wrench.

5. Park vehicle on a clean, dry, flat, level surface and block tires so vehicle cannot roll in either direction.

## Engine Compartment

1. Disconnect both battery cables. Disconnect negative cable first, then positive cable.

## Inside Cab

1. Airbag Fuse

## NOTE

The location of the airbag fuse may vary; check the owner's manual.

- a. Remove fuse cover.
- b. Remove airbag fuse.

# Prepare to Install Kit

## Measurements

1. Measure and record distance between front bumper and fenders.

Driver Side \_\_\_\_\_ Passenger Side \_\_\_\_\_

2. Measure and record distance between rear bumper and bed

Driver Side \_\_\_\_\_ Passenger Side \_\_\_\_\_

3. Measure and record distance between cab and bed.

Driver Side \_\_\_\_\_ Passenger Side \_\_\_\_\_

## Front of Vehicle

1. Disconnect fog light connectors from fog lights if equipped.
2. Remove four bolts and front bumper from frame rails.

## Engine Compartment

1. Airbox

- a. Loosen air intake hose clamp from intake manifold.
- b. Disconnect or remove hoses or wiring harnesses attached to air intake hose.
- c. Release large clamp and remove air intake hose.

2. Radiator

- a. Remove two bolts from radiator supports and core support.
- b. Carefully lift radiator up and off lower mounting pad.
- c. Lower radiator below lower mounting pad.
- d. Remove rubber isolator from lower mounting pad.

3. Remove nut and ground strap from firewall.

#### 4. Steering Shaft

##### **⚠ WARNING**

Accidental deployment of the air bag can result in serious personal injury or death. To avoid accidental deployment during installation of the lift kit, the Supplemental Restraint System (SRS, or airbag) must remain deactivated. Do not allow anyone near the airbag during installation. Refer to the factory service manual or owner's manual for the recommended procedure to disable the SRS. After kit installation, the SRS must be reactivated before driving the vehicle.

##### **⚠ CAUTION**

If the following step is not performed, the airbag clockspring could be damaged. Do not turn the steering wheel while the steering shaft is disconnected.

- a. Strap steering wheel to prevent accidental movement.
- b. Mark upper steering shaft in relation to lower steering shaft.
- c. Remove bolt from junction of upper and lower steering shafts.
- d. Slide lower steering shaft down and out from upper steering shaft.

#### Inside of Vehicle

1. Driver side interior
  - a. Remove O.E. hardware and door jamb scuff plate from driver side door sill.
  - b. Remove kick panel by carefully pulling toward center of vehicle.
  - c. **Extra Cab models:** Fold up rear seat and carefully remove rear side panel.
  - d. Pull back front and rear corners of carpet from floor to access covers.
  - e. Remove front and rear body bolt covers.
  - f. Repeat above steps for passenger side interior.
2. **Manual transmission & Manual 4WD models:** Shift levers
  - a. Remove shift knobs from shift levers.
  - b. Remove shift lever boots and shift lever housings from floor.

#### Underside of Vehicle

1. Parking brake cable
  - a. Separate front cable from rear cable just forward of rear axle on driver side.
  - b. Pull cable through frame mounting bracket beneath driver side door.
2. Remove two ground straps from middle cab mount.
3. **Automatic transmission models:** Disconnect shift cable from shift lever and remove cable from as many clips or brackets as possible along body and/or frame.
4. **Electronic 4WD models:** Remove wiring harness mounting tab from bracket located on rear of transfer case beneath driver side.

#### Rear of Vehicle

1. Disconnect license plate lights from rear bumper.
2. Remove two bolts and rear bumper from frame.

# Install Kit

## Cab

1. Prepare to lift cab from frame
  - a. Loosen, but **DO NOT REMOVE**, cab mounting bolts on driver side.

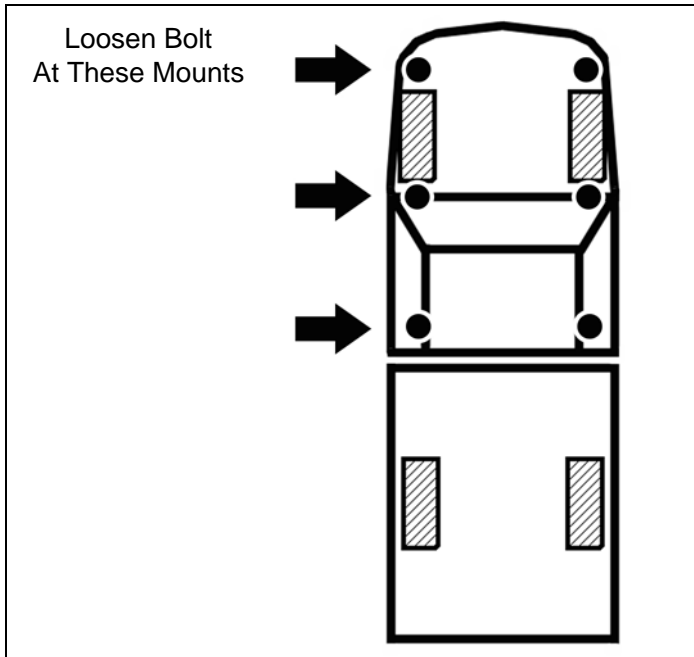

### NOTE

The number of cab mounting bolts may vary with the length of the cab.

- b. Remove bolt from each cab mount on passenger side.

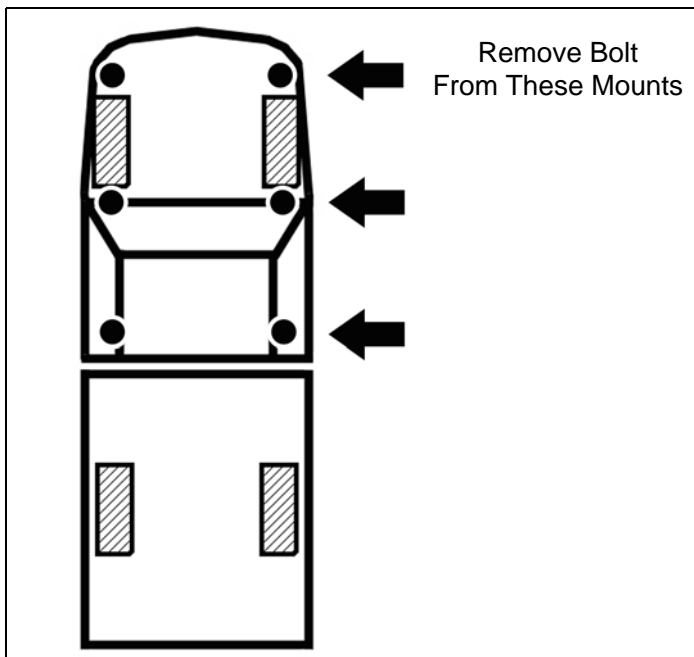

### ⚠ WARNING

Use extreme caution when lifting body from frame. To prevent serious personal injury, ensure the lifting device is securely placed. Keep your hands out from between the body and frame.

### ⚠ CAUTION

Continually check hoses, wires, lines, etc. to be sure that everything is flexing properly and not binding, or damage to the vehicle could result. Be especially careful of the a/c hoses at the fire wall, the belt pulley, and at the core support. Ensure brake lines stretch while lifting. Bending the lines to gain ample slack may be necessary. Be extremely careful not to kink the lines.

2. Cab passenger side

- a. Position a hydraulic floor jack and a wood block under passenger side of cab (under the body seam). Slowly lift cab just enough to install a *kit block* on top of factory upper bushing.

### ⚠ CAUTION

ONLY DRILL OUT FRONT CORE SUPPORT BUSHING SLEEVE as directed in the following procedure. Core support mounts are forward most cab mounts. Drilling any other cab mount bushings will not allow for proper installation of kit.

- b. Remove front core support bushing sleeve and drill out threads with 1/2" drill bit.
- c. Install bushing sleeve into front core support.

### ⚠ WARNING

The *kit blocks* must be installed in addition to the factory upper and lower bushings. Installing the *kit blocks* without the factory upper and lower bushings could result in damage to the vehicle or serious personal injury.

- d. Install *kit blocks* (3" x 3") onto upper bushings on each cab mount.
- e. Lower cab onto *kit blocks* (3" x 3").

- f. Install *kit bolts* on each cab mount as shown below. **DO NOT TIGHTEN.**

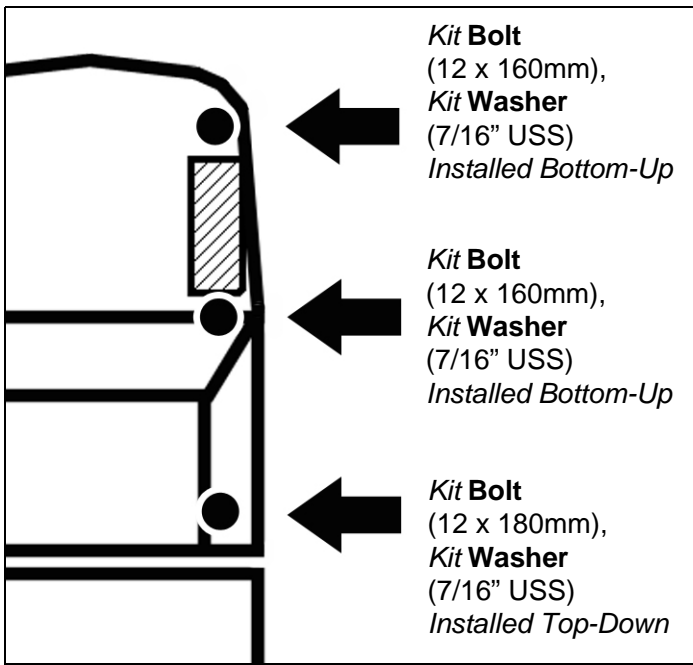

3. Cab driver side
- Repeat previous steps on driver side of cab.
  - Set cab-to-bed spacing according to previous measurement.
  - Remove each *kit bolt*, one at a time, and apply a small amount of *kit Loctite®* onto threads. Install *kit bolt* and *kit washer* (7/16" USS). **TIGHTEN *kit bolt* to 55 ft. lbs.**

## Bed

- Prepare to lift bed from frame
  - Using T55 Torx bit or wrench, loosen, but **DO NOT REMOVE**, bed mounting bolts on driver side (three bolts on vehicles with short bed; four bolts on vehicles with long bed).

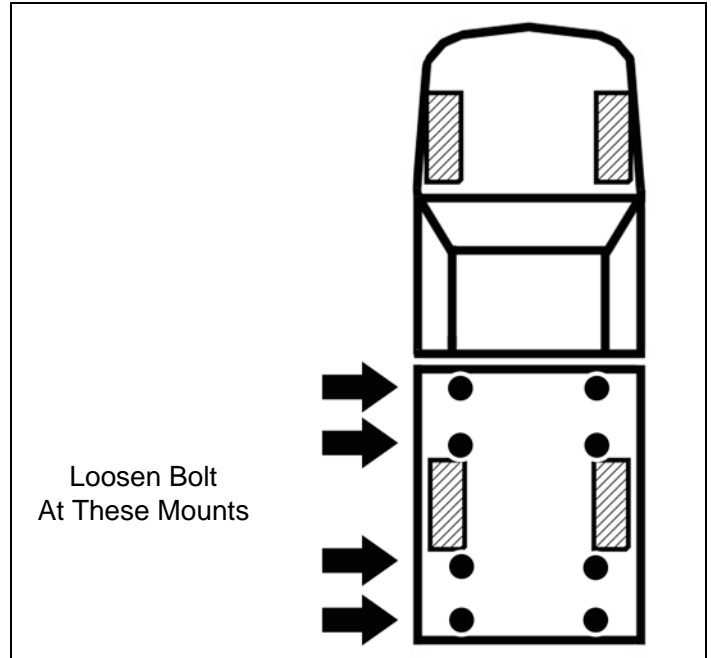

### NOTE

The number of bed mounting bolts may vary with the length of the bed.

- Remove bolt from each bed mount on passenger side.

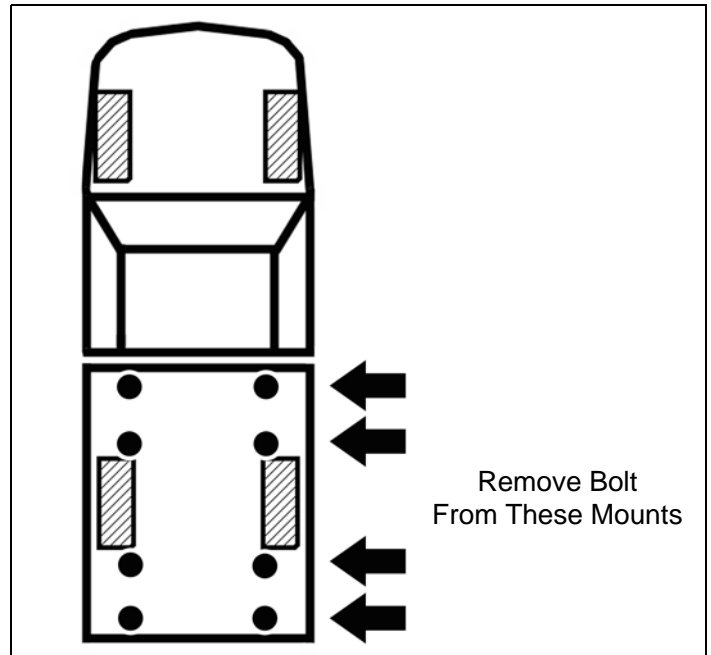

## Rear of Vehicle

### 1. Rear bumper

#### ⚠ WARNING

Use extreme caution when lifting the bed from the frame. To prevent serious personal injury, ensure the lifting device is securely placed. Keep your hands out from between the bed and frame.

#### ⚠ CAUTION

To prevent damage to the vehicle while lifting the bed, continually check hoses, wires, brake lines, etc. to ensure everything is flexing properly and not binding. Ensure clearance between bed and cab is maintained.

#### ⚠ WARNING

The following procedure is intended only to enhance the appearance of the vehicle. The rear bumper will no longer be rated for towing of any kind. Towing with the rear bumper after it has been lifted can result in death, serious personal injury, or damage to the vehicle. Towing after the bumper has been lifted should be accomplished using a rated Class III receiver type hitch.

### 3. Bed passenger side

- Using a hydraulic floor jack and a wood block, slowly lift passenger side of bed a little more than 3".
- Install **kit block** (3" x 3") onto frame at each mount.
- Lower bed onto **kit blocks**.
- Install **kit bolts** on each bed mount as shown below. **DO NOT TIGHTEN.**

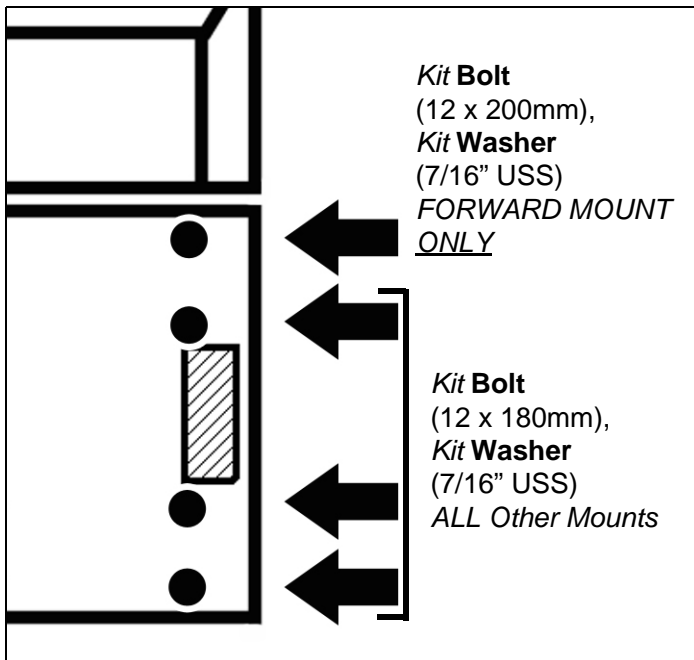

- Remove O.E. hardware and two bumper brackets from bumper.
- Install two **kit brackets** (bumper, rear) with notch oriented downward onto rear bumper with O.E. hardware. **DO NOT TIGHTEN.**
- Install outside support brackets onto center hole of **kit brackets** (bumper, rear) with O.E. hardware. **DO NOT TIGHTEN.**
- Using previously made bumper to bed measurements, position bumper and mark four holes in frame as shown below.
- Remove bumper from vehicle and drill four 1/2" holes (two in each frame rail) at marked locations.
- Install bumper onto frame with four **kit bolts** (7/16" x 1-1/2"), eight **kit washers** (7/16" USS), and four **kit nuts** (7/16" Nylock). **DO NOT TIGHTEN.**

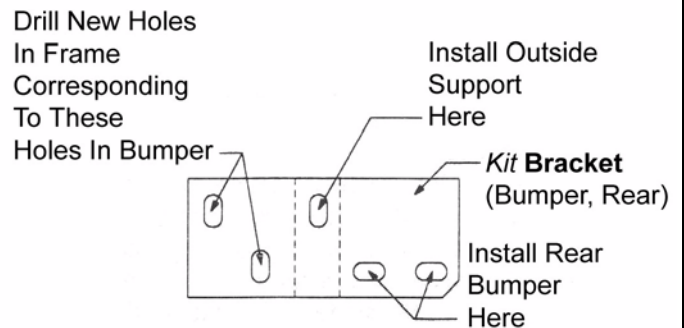

- Repeat previous steps on driver side of bed.
  - Set bed-to-cab spacing according to previous measurement.
  - Remove each **kit bolt**, one at a time, and apply a small amount of **kit Loctite®** onto threads. Install **kit bolt** with **kit washer** (7/16" USS). **TIGHTEN kit bolt** to 55 ft. lbs.
- Using previously made bumper to bed measurements, **TIGHTEN kit bolts** and O.E. hardware. Ensure tailgate lowers and latches properly.
  - Connect license plate lights onto bumper.

## Underside of Vehicle

### 1. Electronic 4WD models: Wiring harness

- a. Wrap wiring harness with *kit bracket* (wire loom).
- b. Install *kit bracket* (wire loom) onto O.E. bracket on transfer case with *kit bolt* (1/4" x 1"), two *kit washers* (1/4" SAE), and *kit nut* (1/4" Nylock).
- c. Ensure sufficient slack in wiring harness.

### 2. Connect two ground straps onto middle body mount with O.E. hardware.

### 3. Parking brake cable

- a. Using *kit bracket* (parking brake) as a template, drill two 5/16" holes into mounting bracket beneath driver door as shown below.
- b. Install *kit bracket* (parking brake) onto mounting bracket with two *kit bolts* (1/4" x 1"), four *kit washers* (1/4" SAE), and two *kit nuts* (1/4" Nylock).
- c. Route front cable through *kit bracket* (parking brake) and install onto rear cable at junction.

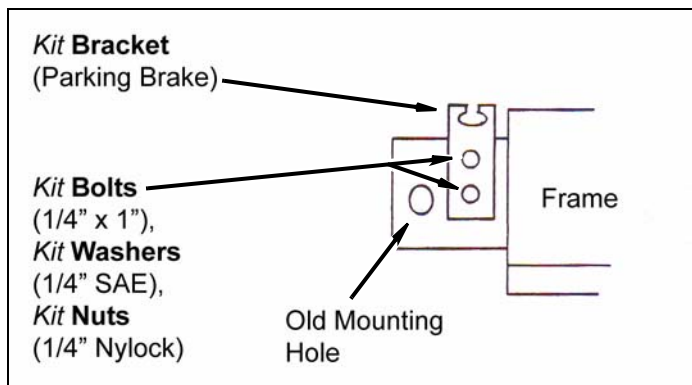

- d. Adjust parking brake cable if necessary.

### 4. Automatic transmission models: Shift cable

- a. Install shift cable onto shifter.
- b. Install shift cable onto as many clips and brackets as possible without bending or kinking shift cable.

### 5. Crush blocks

#### ⚠ CAUTION

All welding should be performed by a certified welder or welding shop.

- a. Position two (four on long bed models) crush blocks onto frame directly below where bed rails cross frame rails.
- b. Tack weld crush blocks onto frame.

## Inside of Vehicle

### 1. Manual transmission & Manual 4WD models: Shift levers

- a. Install shift lever housings onto floor with O.E. hardware.
- b. Install shift boots onto shift levers.
- c. Check operation of transmission and transfer case.
- d. If proper gear selection is difficult or impossible, remove shift boot and shift housing.
- e. If shift levers contact floor in one or more positions, notch floor and check shift operation again.
- f. If proper gear selection is difficult or impossible, repeat notching floor until proper gear selection is attained.
- g. Install shift lever housings onto floor with O.E. hardware.
- h. Install shift boots onto shift levers.
- i. Install shift knobs onto shift levers.

### 2. Driver side interior

- a. Install two body bolt covers onto floor.
- b. Lay carpet flat onto floor.
- c. Install rear side panel onto cab.
- d. Install kick panel onto cab.
- e. Install door jamb scuff plate onto door sill with O.E. hardware.

## Engine Compartment

### 1. Steering shaft



#### ⚠ WARNING

Verify the steering extension is securely installed as specified in the instructions. Failure to do so may cause steering malfunction, resulting in property damage or serious personal injury.

- a. Install **kit extension** (steering) onto upper steering shaft. Ensure marks on upper steering shaft and lower steering shaft are aligned.
  - b. Install lower steering shaft onto **kit extension** (steering), ensuring marks on upper steering shaft and lower steering shaft are aligned.
  - c. Apply a small amount of **kit Loctite®** onto O.E. bolt and **kit bolt** (3/8" x 1-1/2").
  - d. Install and TIGHTEN O.E. bolt to 33 lb.-ft.
  - e. Install upper steering shaft onto **kit extension** (steering) with **kit bolt** (3/8" x 1-1/2"), two **kit washers** (3/8" SAE), and **kit nut** (3/8" Nylock).
  - f. Install and TIGHTEN **kit bolt** to 33 lb.-ft.
- ### 2. Firewall ground strap
- a. Install **kit bracket** (3" w/ stud) onto firewall stud with O.E. nut.
  - b. Install ground strap onto **kit bracket** (3" w/ stud) with **kit washer** (1/4" SAE) and **kit nut** (1/4" Nylock).

### 3. Radiator

- a. Install rubber isolator onto two **kit brackets** (tube, radiator).
- b. Position **kit brackets** (tube, radiator) around radiator arm so arm will rest on **kit brackets** (tube, radiator).
- c. Install radiator and **kit brackets** (tube, radiator) onto bottom of lower mounting pad with two **kit bolts** (5/16" x 1"), two **kit washers** (5/16" USS), and two **kit u-nuts** (5/16"). DO NOT TIGHTEN.
- d. Install two **kit brackets** (3" w/ studs) onto core support with two O.E. bolts where radiator was previously mounted. DO NOT TIGHTEN.
- e. Install radiator onto two **kit brackets** (3" w/ stud) with two **kit washers** (1/4" SAE) and two **kit nuts** (1/4" Nylock). DO NOT TIGHTEN.
- f. Adjust fan to fan shroud clearance and ensure fan blades DO NOT contact fan shroud.
- g. TIGHTEN all radiator mounting hardware.

### 4. Airbox

- a. Install air intake hose onto intake manifold with large clamp.
- b. Install air intake hose onto airbox with clamp.
- c. Install hoses or wiring harnesses onto air intake hose or airbox removed during disassembly.

## Front of Vehicle

### 1. Front bumper

- a. Test fit bumper onto vehicle without brackets. Note any clearance issues.
- b. **Fog light models:** Notch bottom outside corners of frame rails.
- c. Install two **kit brackets** (bumper, front) onto O.E. bumper mounted brackets with four **kit bolts** (7/16" x 1-1/2"), eight **kit washers** (7/16" USS), and four **kit nuts** (7/16" Nylock). DO NOT TIGHTEN. Note where O.E. bracket interferes with rear upper hole in **kit brackets** (bumper, front).
- d. Notch frame bumper mount brackets as shown below without interfering with O.E. mount.
- e. Remove two **kit brackets** (bumper, front).



- f. Install two **kit brackets** (bumper, front) onto two bumper mounted brackets.
- g. Test fit bumper onto vehicle with brackets and mark hole in each bumper mounted bracket as shown below.
- h. Drill 1/2" hole in each bumper mounted bracket.
- i. Apply a small amount of **kit Loctite®** onto threads of all bolts and install two **kit brackets** (bumper, front) onto O.E. bumper mounted brackets with four **kit bolts** (7/16" x 1-1/2"), eight **kit washers** (7/16" USS), and four **kit nuts** (7/16" Nylock). DO NOT TIGHTEN.
- j. Install bumper and two **kit brackets** (bumper, rear) onto frame with O.E. hardware. DO NOT TIGHTEN.
- k. **Fog light models:** Test fit bumper onto vehicle and trim lower valence around fog light openings if necessary.
- l. Adjust bumper according to previously recorded bumper-to-fender measurements and TIGHTEN all bumper hardware.

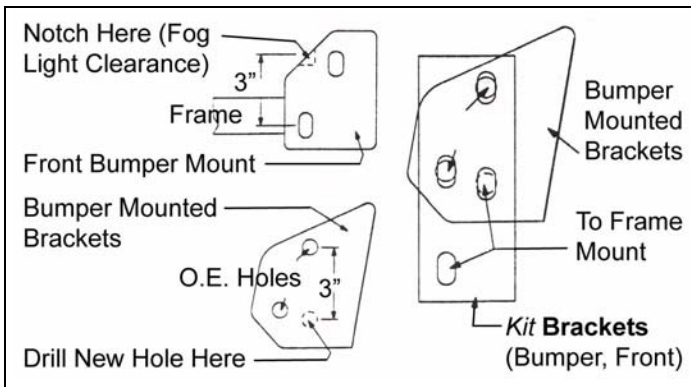

## After Completing Installation

### Inside Cab

1. Install airbag fuse and fuse block cover.

### Engine Compartment

1. Connect both battery cables. Connect positive cable first, then negative cable.
2. Install airbag fuse and fuse block cover.

## Miscellaneous

1. Check steering
  - a. If steering binds during operation, remove O.E. hardware and steering column flange from firewall.
  - b. Drill out flange holes toward top as far as possible.
  - c. Pull steering column down as far as possible.
  - d. Install steering column flange onto firewall with O.E. hardware.
2. Apply **kit label** (warning) onto dashboard in plain sight of all vehicle occupants.
3. Check all fasteners to ensure they are tight.
4. Ensure all wires, hoses, cables, etc. are properly connected and there is ample slack.
5. Adjust headlights.

### ⚠ WARNING

If the engine cooling system is hot, the coolant will be HOT and UNDER PRESSURE. To prevent serious personal injury, wait until the cooling system is completely cool before removing the cap from the radiator.

6. Start engine and top off cooling system. Purge air from cooling system according to manufacturer's instructions. Install radiator cap.

## Dynamic Vehicle Check

1. Check steering in both directions to ensure that there is no bind. Check operation of clutch, brake system, and parking brake. Check operation of transmission and transfer case. Ensure there is full engagement in all gears and 4WD ranges. Check battery connections and electrical component operations. Test-drive vehicle.

### ⚠ WARNING

Retorque all fasteners after 500 miles and after off road use. All body lift components should be visually inspected and fasteners retorqued during routine vehicle servicing.

**⚠ CAUTION**

Performance Automotive Group does not recommend any particular wheel and tire combinations for use with its body lifts and cannot assume responsibility for the customer's choice of wheels and tires. Refer to your owner's manual for recommended tire sizes and warnings related to the use of oversized tires. Larger wheel and tire combinations increase stress and wear on steering and suspension components, which leads to increased maintenance and higher risk for component failure. Larger wheel and tire combinations also alter speedometer calibration, braking effectiveness, center of gravity, and handling characteristics. Consult an experienced local off road shop to find what wheel and tire combinations work best with your vehicle.

**NOTE**

All warranty information, instruction sheets, and other documents regarding the installation of this product must be retained by the vehicle owner. Information contained in the instructions and on the warranty card will be required for any warranty claims. The vehicle owner needs to understand the modifications made to the vehicle and how they affect vehicle handling and performance. Failure to provide the customer with this information can result in damage to the vehicle and severe personal injury.

## Accessories

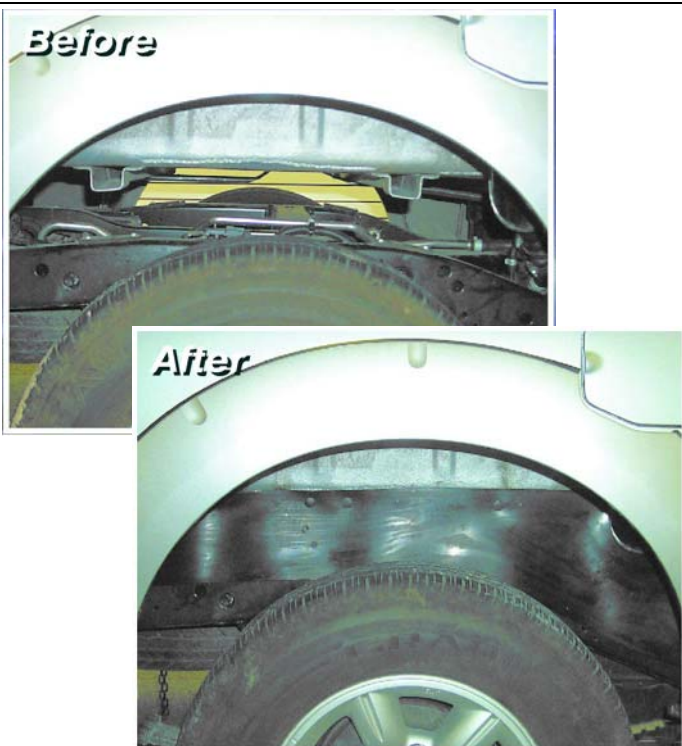
**Gap Guards****1995****Kit# 6727****1996-1997****Kit# 6732****1996-1997 Splash****Kit# 6733**

## Kit Parts List

**Qty. Description**

14 **Block** (3" x 3")  
 4 **Block** (crush)  
 2 **Bracket** (bumper, front)  
 2 **Bracket** (bumper, rear)  
 2 **Bracket** (tube, radiator)  
 1 **Label** (logo)  
 1 **Label** (warning)  
 1 **Loctite®** (6ml bottle)  
 2 **U-nut** (5/16")

1 **BP853 (Bolt pack)**  
 2 **Bolt** (5/16" x 1")  
 1 **Bolt** (3/8" x 1-3/4")  
 4 **Bolt** (12mm x 160mm)  
 8 **Bolt** (12mm x 180mm)  
 2 **Bolt** (12mm x 200mm)  
 1 **Bracket** (parking brake)  
 1 **Extension** (steering)  
 2 **Nut** (5/16" Nylock)  
 1 **Nut** (3/8" Nylock)  
 4 **Washer** (5/16" USS)  
 14 **Washer** (7/16" USS)  
 2 **Washer** (3/8" SAE)

**1 HP853 (Hardware pack)**

3 **Bolt** (1/4" x 1")  
 2 **Bolt** (5/16" x 1")  
 8 **Bolt** (7/16" x 1-1/2")  
 3 **Bracket** (3" w/ stud)  
 6 **Nut** (1/4" Nylock)  
 8 **Nut** (7/16" Nylock)  
 9 **Washer** (1/4" SAE)  
 2 **Washer** (5/16" USS)  
 16 **Washer** (7/16" USS)

**NOTE**

Depending on the vehicle configuration (automatic or manual transmission, 2WD or 4WD, cab length, bed length, etc.), some parts may not be used.