



Cargo Cover

Installation Instructions

For: Jeep TJ
2003 – 2006
Part Number: 41826



Cargo Cover shown with Sun Cap and Cab Curtain (sold separately)

DO NOT INSTALL THIS PRODUCT ON ANY VEHICLE OTHER THAN THOSE LISTED ABOVE.
This product is only designed for the vehicles listed above. Failure to install this product on the proper vehicle could cause injury to the vehicle occupants and damage to the product.

Installation Tips

Before you begin installing this assembly, read all instructions thoroughly.

For a smooth fit:

For ease in installation, the product should be installed at temperatures above 72° F. Below this temperature, the fabric may contract an inch or more, making it difficult to fit to the vehicle. It is normal for fabric to contract and wrinkle when stored in the shipping carton. Within a few days after the installation, the fabric will relax and the wrinkles will disappear.



WARNING

This product is designed to enhance the appearance of the vehicle. Do not rely in any way on the components of this product to contain occupants within the vehicle, or to protect against injury or death in the event of an accident. Never operate vehicle in excess of manufacturer's specifications.

WEAR SEAT BELTS AT ALL TIMES

Read and follow, precisely, all installation instructions provided when installing this product. Failure to do so could place occupants of the vehicle in a potentially dangerous situation. After installing or reinstalling, check to make sure it has been properly installed.

Step One

SECURE REAR SEAT

Locate the Web Buckle Strap in the parts kit. Thread the web end of the strap through the footman loop closest to the rear of the seat on the Driver's side. Fold the back of the seat down and thread the web through the bar on the seat back. Thread the end of the strap through the buckle and pull it tight. Tightening the strap securely will keep the seat from banging when the vehicle is moving.

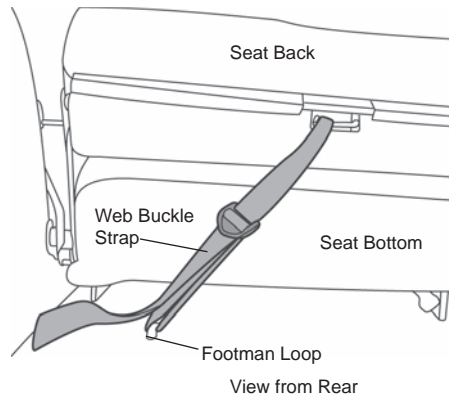

Parts List

| | |
|------------------|---------|
| Cargo Cover | Qty - 1 |
| Web Buckle Strap | Qty - 1 |

Step Two

FOLD DOWN TOP

Remove the Rear Quarter Windows and Rear Window from the top. Remove the Tailgate Retainer from the Rear Window. Cover the "glass" in the Rear Quarter Windows and the Rear Window and store them while not in use. Release the front of the top from the windshield. Raise the front of the deck and collapse the rear bows, tucking the two plastic strips above the door openings and the stay pad on the rear bow inside of the bows.

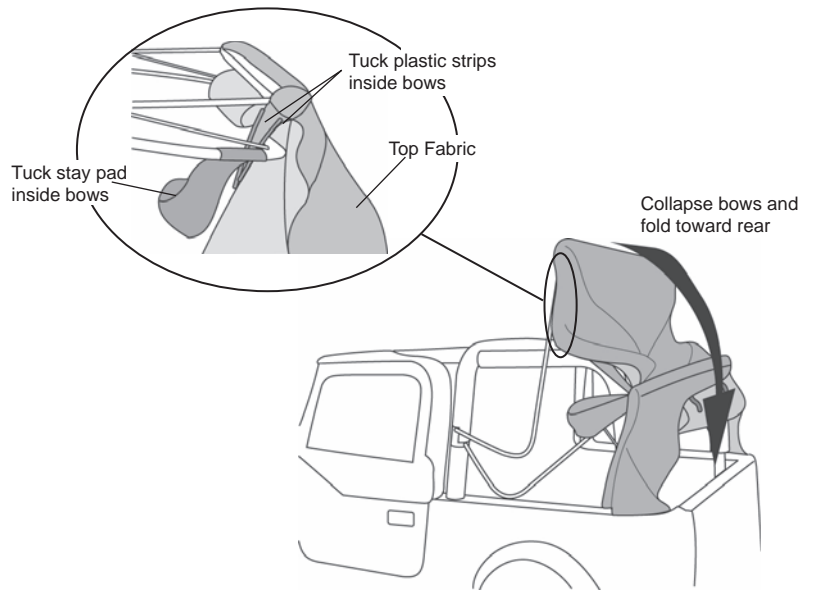

Step Three

WRAP FABRIC AROUND BOWS

Lay the bows down along the rear of the vehicle. Wrap the fold of fabric from the rear of the vehicle up around the bows. Then tuck the rear legs of top under the bows and wrap them around the deck fabric as tight as possible. Tuck the fabric and bows down into the tub as far as possible.

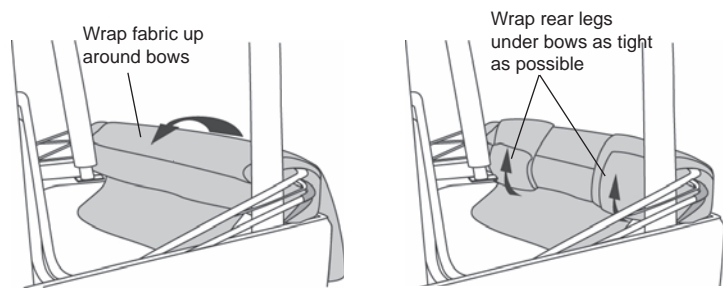

Step Four

INSTALL TAILGATE BAR

From the back of the vehicle, hold the Cargo Cover with the backing side toward you. Slide the tubing into the channel in the Tailgate Retainer and install the retainer into the Tailgate Retainer Mount.

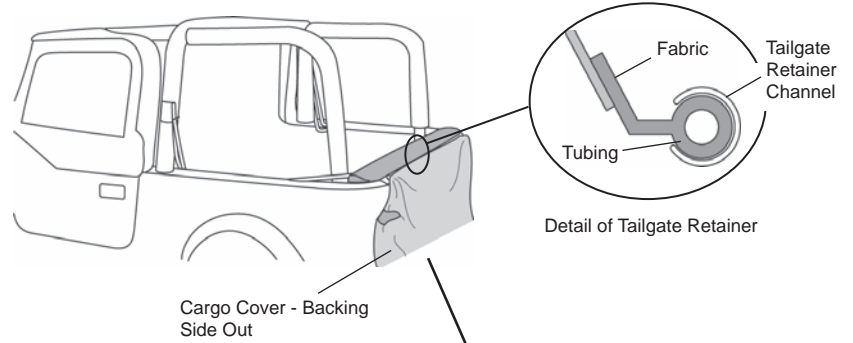

Step Five

SECURE WEB STRAPS

Drape the fabric forward over the rear of the vehicle and locate the web straps, with buckles attached, on the front of the Cargo Cover. Wrap the straps around the front sport bars and thread the ends loosely through the buckles. Do not pull the straps tight at this time.

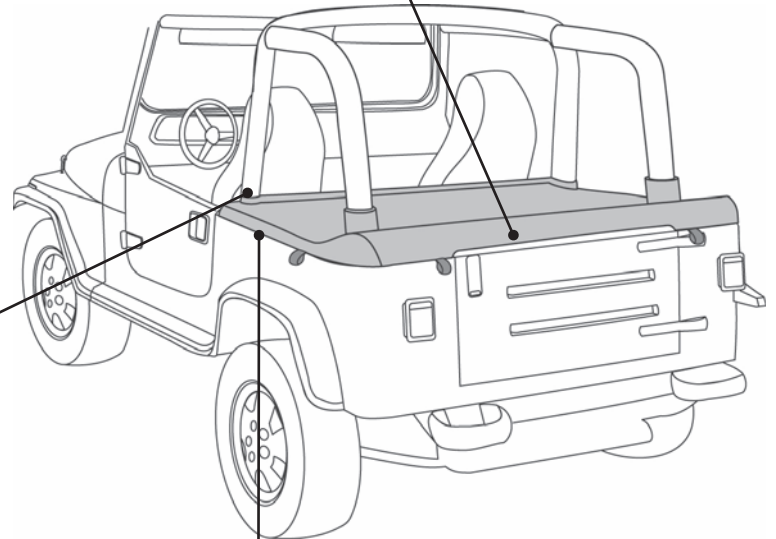
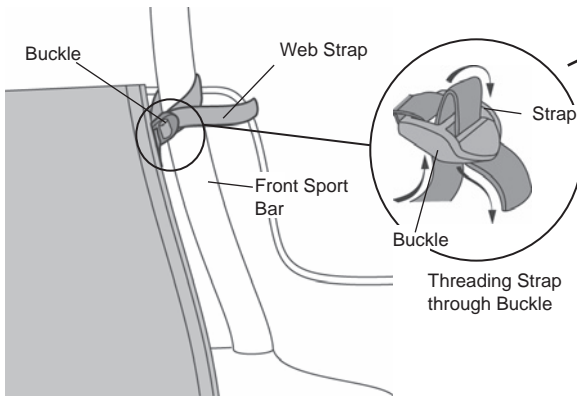

Step Six

SECURE PLASTIC STRIPS

Locate the plastic strip sewn to the Cargo Cover along each side of the vehicle. Start at one end on each side and roll the plastic strip into the Side Retainers.

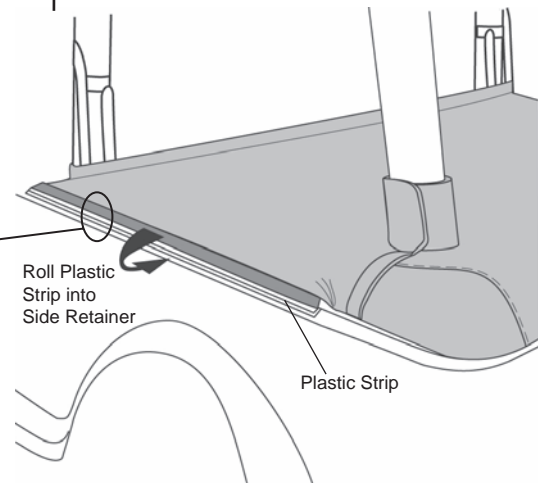
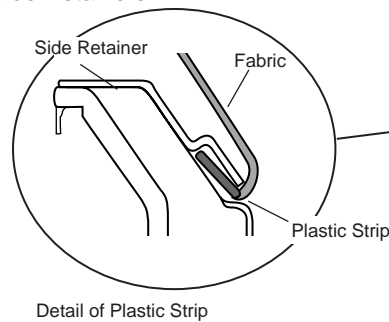

Step Seven

SECURE REAR CORNERS

Roll the plastic strips, sewn into the rear corners of the Cargo Cover into the Corner Retainers. Slide the corner plastic strip toward the front of the vehicle and make sure that the plastic strip fits up into the retainer so that the collar fits properly.

NOTE The Fabric Protector sewn into the fabric must be located over the Tailgate Retainer Mounts.

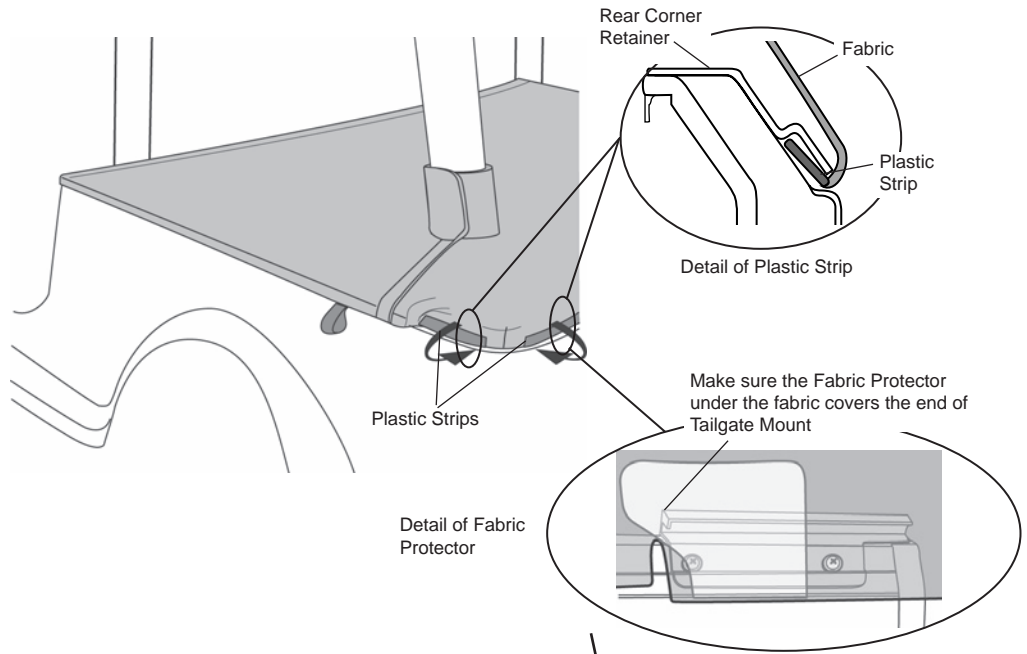

Step Eight

SECURE COLLARS

Tuck the seat belt assemblies into the rear sport bar collars and close the rear sport bar collars by pulling firmly on the fabric and fastening the Hook and Loop Strips to each other.

Tighten the straps on the front of the Cargo Cover.

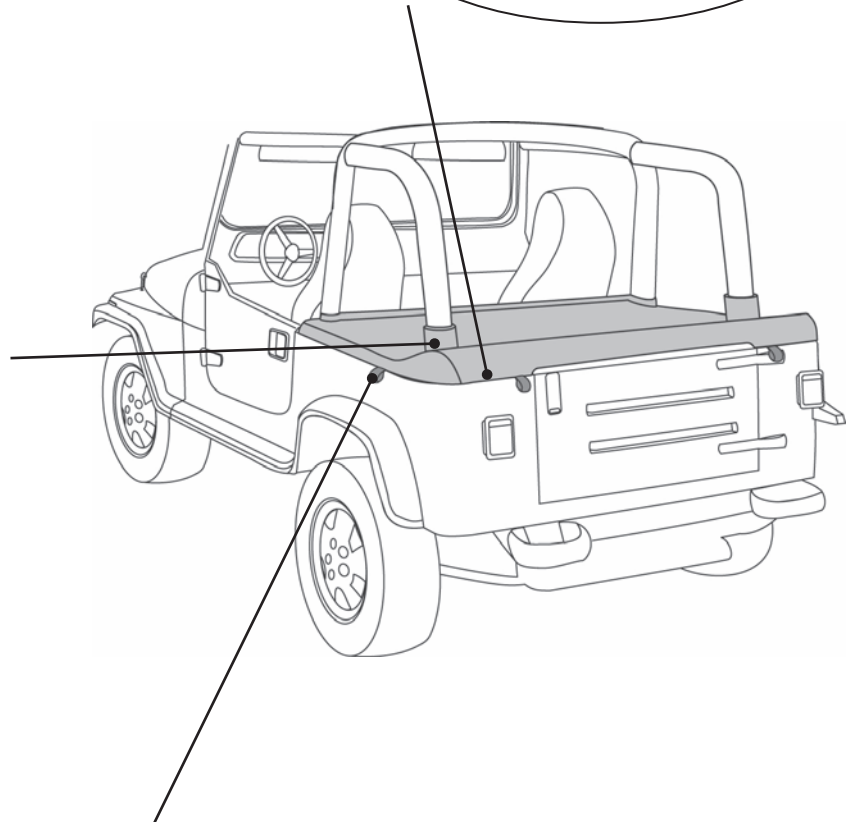
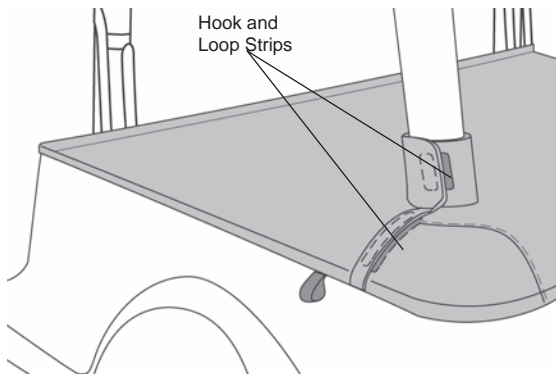

To Remove Cargo Cover

When removing the Cargo Cover, use the loops sewn to the fabric to release the plastic strips. Pull gently down, then straight out to release the plastic strip from the retainers.

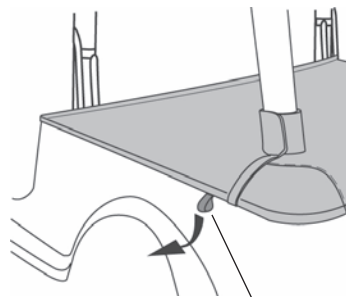

Pull gently down, then out to release plastic strip

If You Have a New Cab Curtain on Your Vehicle

Optional Installation

Step One - Optional

Locate Attaching Snaps from Hardware Kit supplied with the Cab Curtain.

Step Two - Optional

Locate the flap sewn to the vinyl side of the Cab Curtain. Pull the flap out over the top of the front edge of the Cargo Cover.

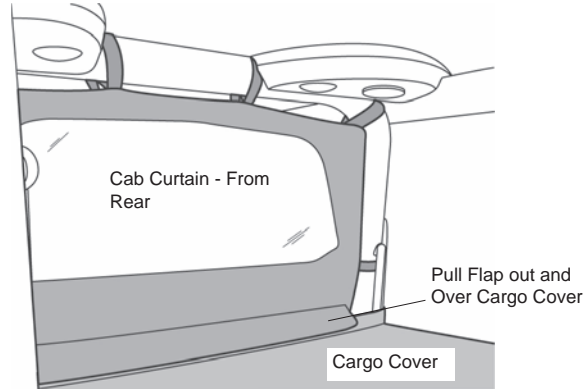

Step Three - Optional

Pull up on the front, reinforced edge of the Cargo Cover and mark the locations matching the three snaps on the Cab Curtain flap, on the doubled fabric along the top of the Cargo Cover.

Step Four - Optional

At the marked locations, push the sharp end of a Snap Head Screw through the Cargo Cover at the marked locations, to make a hole. Once a hole is formed, pull the screw back out of the hole. Then push the screw through the hole from the vinyl side so that the snap is on top of the vinyl. Thread an Acorn Locknut over the pointed end of the Snap Head Screw. Snap the Cargo Cover and the Cab Curtain together with the three snaps.

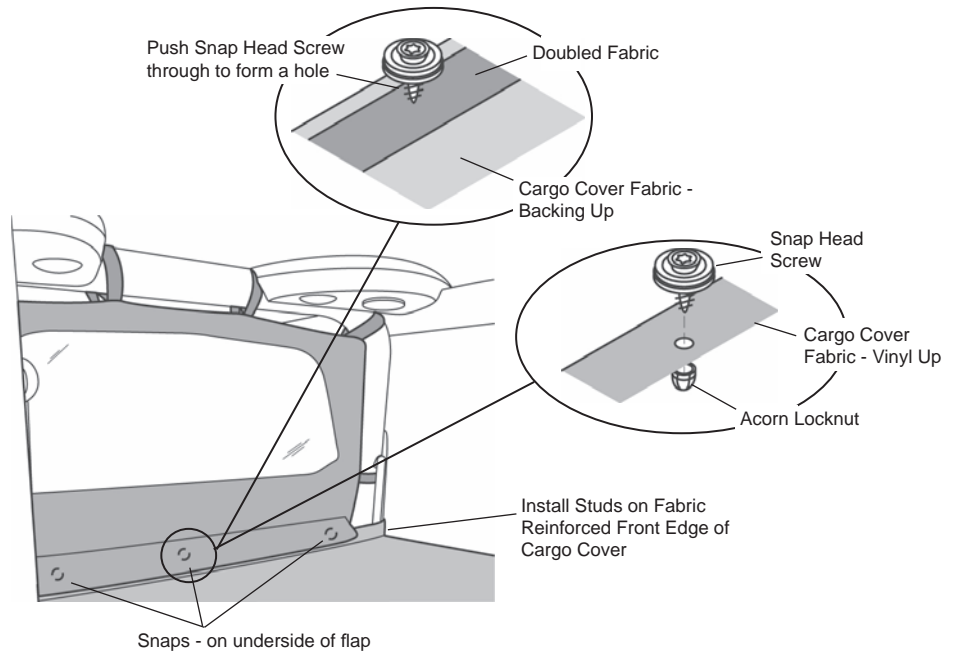

Care and Maintenance of your New Cargo Cover

Your Cargo Cover is made of the finest materials available. To keep it looking new and for the maximum possible wear, it will need periodic cleaning and maintenance.

Washing: The fabric should be washed often using soap, warm water and a soft bristle brush. Rinse with clear water to remove all traces of soap.

Water: Seeping through at the seams may be stopped by applying 3-M Scotchgard® on the inside of the seams. Rips in the fabric may be repaired with Bondex® iron on patches. Iron the patches to the Inside of the top, carefully following the Bondex® instructions.

Snaps: Keep snaps cleaned and lubricated with silicone to help prevent snaps from sticking to the studs. If a snap does become stuck to a stud, use a screwdriver and GENTLY pry apart to prevent permanent damage to the snap or the top fabric.

LIMITED WARRANTY

We warrant our product to be free from defects in material and workmanship, for terms specified below, provided there has been normal use and proper maintenance. This warranty applies to the original purchaser only. All remedies under this warranty are limited to the repair or replacement of any item or items found by the factory to be defective within the time period specified.

If you have a warranty claim, first you must call our factory at the number below for instructions. You must retain proof of purchase and submit a copy with any items returned for warranty work. Upon completion of warranty work, if any, we will return the repaired or replaced item or items to you freight prepaid. Damage to our products caused by accidents, fire, vandalism, negligence, misinstallation, misuse, Acts of God, or by defective parts not manufactured by us, is not covered under this warranty.

THE WARRANTY TIME PERIOD IS AS FOLLOWS: ALL "GOODS" MANUFACTURED BY OUR COMPANY: ONE YEAR FROM DATE OF PURCHASE.

ANY IMPLIED WARRANTIES OF MERCHANTABILITY AND/OR FITNESS FOR A PARTICULAR PURPOSE CREATED HEREBY ARE LIMITED IN DURATION TO THE SAME DURATION AND SCOPE AS THE EXPRESS WRITTEN WARRANTY. OUR COMPANY SHALL NOT BE LIABLE FOR ANY INCIDENTAL OR CONSEQUENTIAL DAMAGE.