



# Fabric Replacement Top Installation Instructions

**For: Suzuki Samurai  
With Tinted Windows**

**Part Number: 51383**

This Pavement Ends Soft Top requires all factory original equipment hardware to complete the installation.

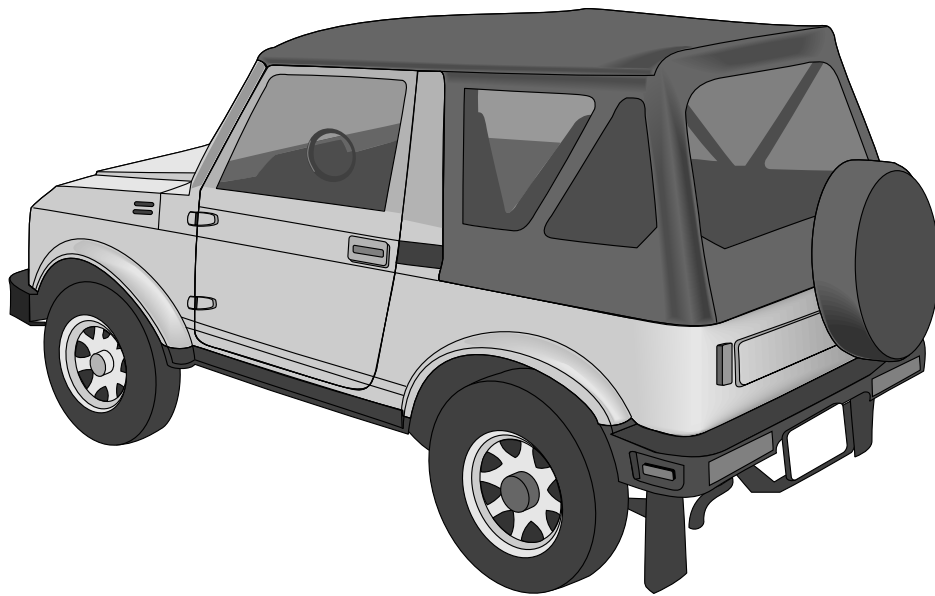

## WARNING

This product is designed to enhance the appearance of the vehicle and to shield the occupants from ordinary weather conditions. Do not rely in any way on the components of this product to contain occupants within the vehicle, or to protect against injury or death in the event of an accident. This top will not protect the occupants from falling objects. Never operate vehicle in excess of manufacturer's specifications.

**WEAR SEAT BELTS AT ALL TIMES**

Read and follow, precisely, all installation instructions provided when installing top. Failure to do so may result in a poor fitting top and could place occupants of the vehicle in a potentially dangerous situation. After installing or reinstalling the top, check to make sure it has been properly installed.

## Installation Tips

*Before you begin installing this top assembly, read all instructions thoroughly. After completing the installation, keep these instructions for future reference. Below are a few tips to make this installation easier.*

### **For a smooth fit:**

For ease in installation, the top should be installed at temperatures above 72° F. Below this temperature, the fabric may contract an inch or more, making it difficult to fit to the vehicle.

It is normal for the fabric to contract and wrinkle when stored in the shipping carton. Within a few days after the installation, the fabric will relax and the wrinkles will disappear.

**Parts List**  
**Fabric Top** Qty - 1

**CAUTION**  
 Safety glasses should be worn at all times while installing this product.

**Step One**

Orient the top with the two snaps toward the front of the vehicle. Drape it over the vehicle. Open the hook and loop flaps over the doors. Snap the front snaps to the vehicle. Center the plastic strip and slip only the plastic into the channel along the top of the windshield.

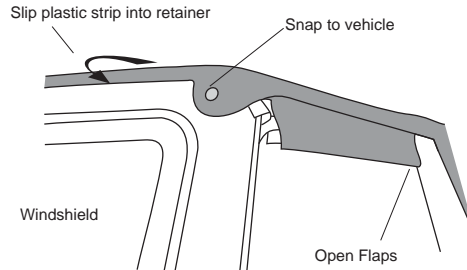

**Step Two**

Drape the top over the rear bow. Slide the front edges of the side panels into the channel on the rear of the Sport Bar.

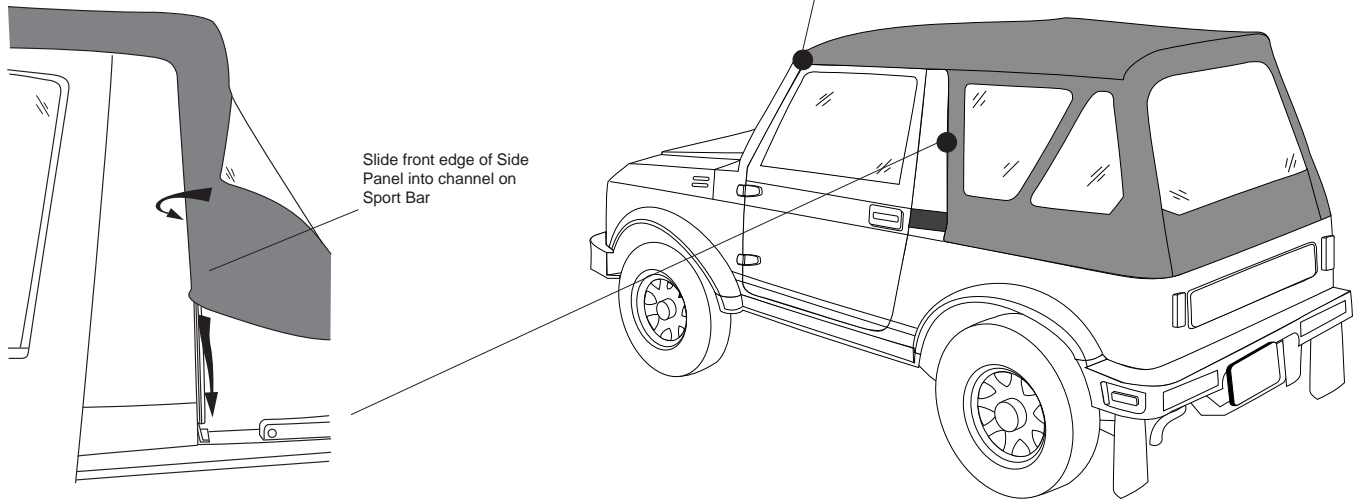

### Step Three

Make sure that the straps sewn into the rear of the top are behind the rear bow.

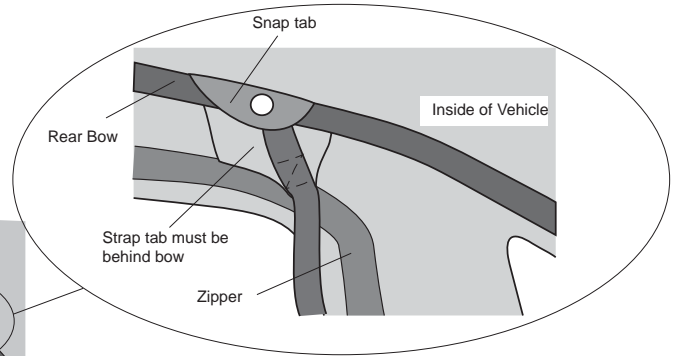
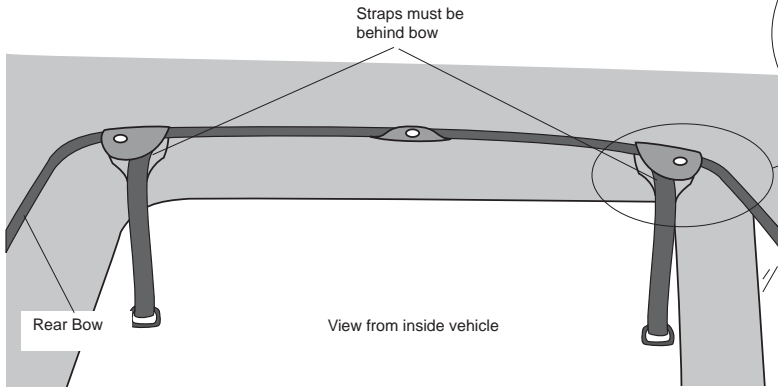

### Step Four

Thread the Tension Strap through the loop on the strap sewn into the rear of the top. Pull the strap tight and secure it in place with the hook and loop sewn to the strap.

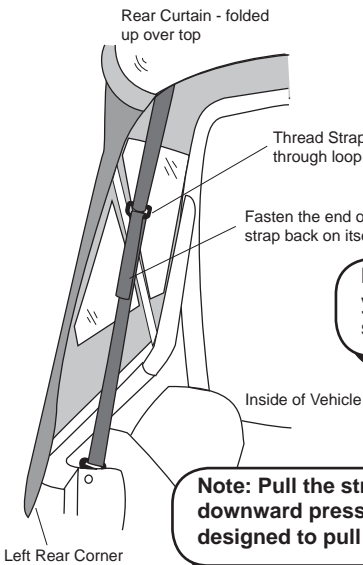

**Note: If this strap is missing from your vehicle, contact Customer service to order 243.53P Strap Kit.**

**Note: Pull the strap tight. Do not put excessive downward pressure on this rear strap. It is not designed to pull the bow assembly downward.**

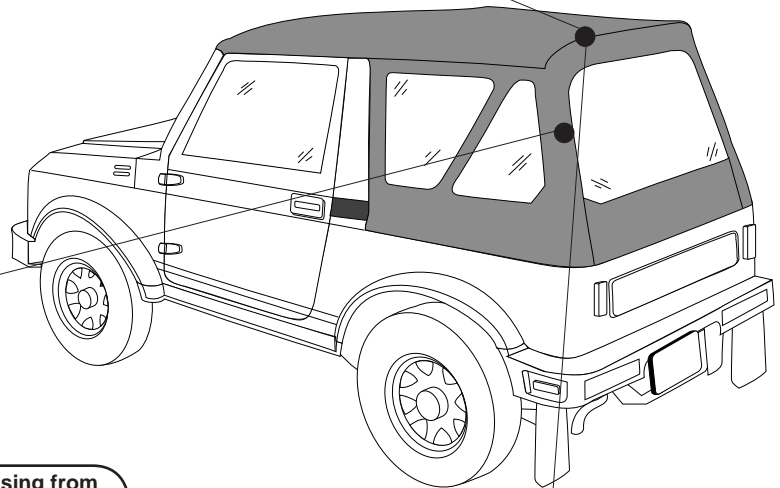

### Step Five

Snap the top to the rear bow. The center snap flap will wrap around the bow from behind and the two outer snap flaps will wrap around the bow from the front.

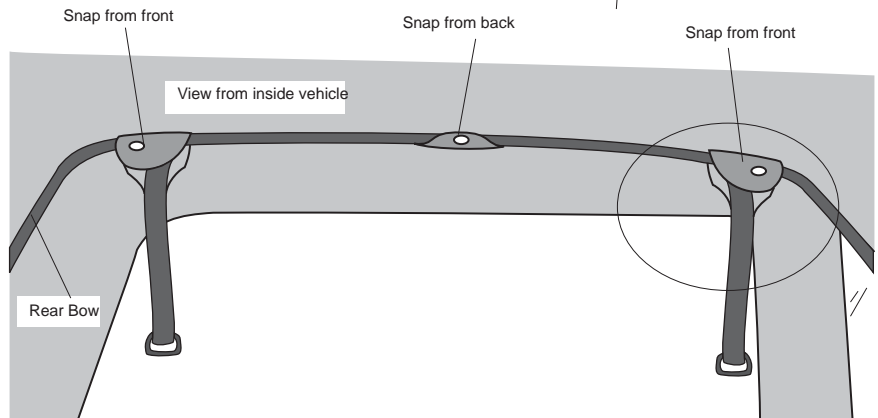

## Step Six

Snap the snaps on the bottom of the side panels from front to back.

Fasten the bottom of the Rear Curtain to the Lift-A-Dots on the rear of the vehicle.

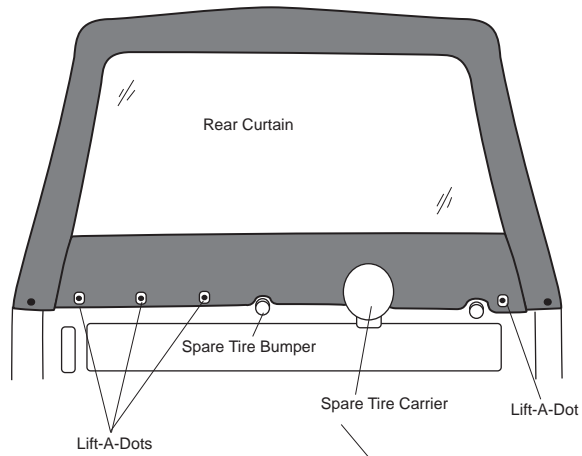

## Step Seven

Wrap flaps around door frames and attach hook strips to loop strips.

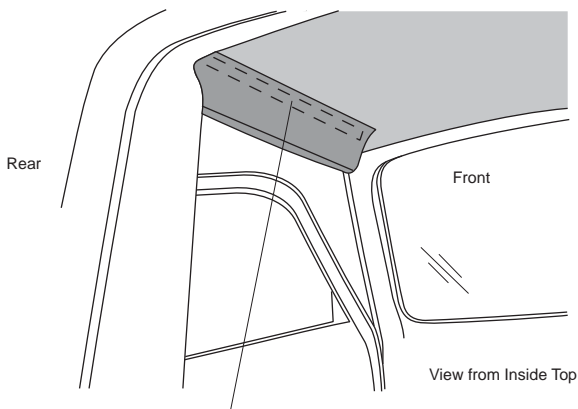

Wrap flap around door frame and fasten hook and loop

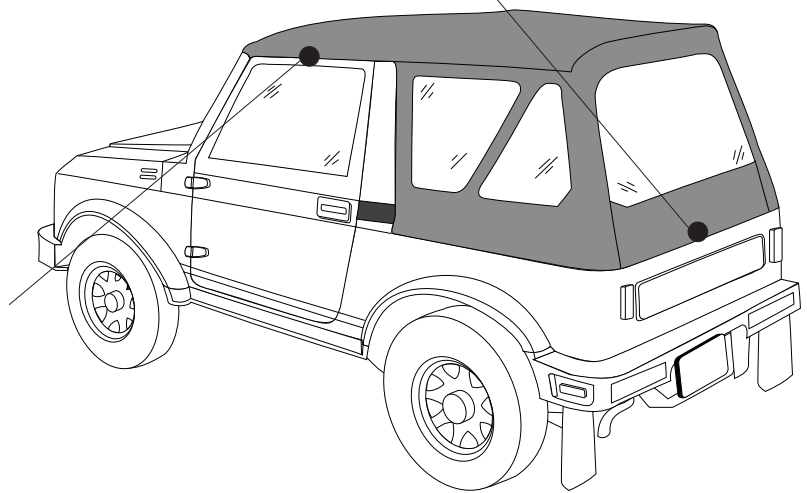

## Adjusting the Top

### Rear Curtain

To roll up the Rear Curtain, start at the bottom and roll it to the inside. Avoid wrinkles in the fabric and window. Secure it in place with the curtain straps inside of the top.

**WARNING:** When operating the vehicle with the rear window open, one or more door windows should be open for proper ventilation.

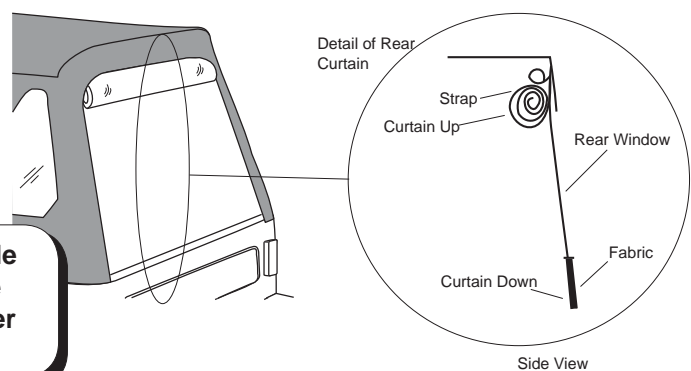

## Care and Maintenance of your Bestop Product

Your Bestop product is made of the finest materials available. To keep it looking new and for the maximum possible wear, it will need periodic cleaning and maintenance.

**Washing:** The fabric should be washed often using soap, warm water and a soft bristle brush. Rinse with clear water to remove all traces of soap or use Bestop-recommended Bestop Cleaner and Bestop Protectant. Bestop Cleaner and Bestop Protectant are specially formulated to provide a total cleaning and protection system. Bestop Cleaner will not harm vehicle finish, is biodegradable and environmentally friendly. Bestop Protectant protects against UV-fading, cracking and hardening.

**Windows:** Keep windows clean to avoid scratching. DO NOT use a brush on the windows! Wash with a water-soaked cloth or sponge and a mild dishwashing detergent or use Bestop-recommended Bestop Vinyl Window Cleaner, which safely cleans and protects vinyl windows while helping prevent UV damage. NEVER WIPE THE WINDOWS WHEN THEY ARE DRY. Be careful when cleaning snow or frost from the vinyl windows since they are easily scratched and may crack at low temperatures. DO NOT roll the sides or rear window in cold weather. The windows become stiff and will crack.

**Zippers:** Keeping the zipper cleaned and lubricated with a silicone lubricant will help prevent damage and keep the zippers in a smooth working condition. If a zipper opens behind the slider, the slider may have been spread apart. This problem can usually be repaired by using an ordinary pair of pliers to bring the sides back into parallel. Return slider to the end of the zipper in the normal Open position. Squeeze lightly at first and test the zipper. If the zipper continues to remain open squeeze more firmly with the pliers and try the zipper again. Repeat this procedure until the zipper operates correctly.

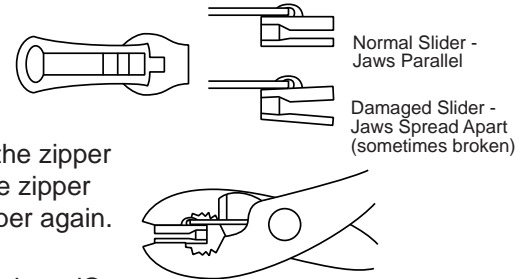

**Water:** Seeping through at the seams may be stopped by applying 3-M Scotchgard® on the inside of the seams. Rips in the fabric may be repaired with Bondex® iron on patches. Iron the patches to the Inside of the top, carefully following the Bondex® instructions.

**Snaps:** Keep snaps cleaned and lubricated with silicone to help prevent snaps from sticking to the studs. If a snap does become stuck to a stud, use a screwdriver and GENTLY pry apart to prevent permanent damage to the snap or the top fabric.

## LIMITED WARRANTY

We warrant our product to be free from defects in material and workmanship, for the terms specified below, provided there has been normal use and proper maintenance. This warranty applies to the original purchaser only. All remedies under this warranty are limited to the repair or replacement of any item or items found by the factory to be defective within the time period specified.

If you have a warranty claim, first you must call our factory at the number below for instructions. You must retain proof of purchase and submit a copy with any items returned for warranty work. Upon completion of warranty work, if any, we will return the repaired or replaced item or items to you freight prepaid. Damage to our products caused by accidents, fire, vandalism, negligence, misinstallation, misuse, Acts of God, or by defective parts not manufactured by us, is not covered under this warranty.

THE WARRANTY TIME PERIOD IS AS FOLLOWS: ALL "SOFT GOODS" MANUFACTURED BY OUR COMPANY (USING PRIMARILY VINYL, PLASTICS, AND/OR FOAM): ONE YEAR FROM DATE OF PURCHASE.

ANY IMPLIED WARRANTIES OF MERCHANTABILITY AND/OR FITNESS FOR A PARTICULAR PURPOSE CREATED HEREBY ARE LIMITED IN DURATION TO THE SAME DURATION AND SCOPE AS THE EXPRESS WRITTEN WARRANTY. OUR COMPANY SHALL NOT BE LIABLE FOR ANY INCIDENTAL OR CONSEQUENTIAL DAMAGE.

Some states do not allow limitations on how long an implied warranty lasts, or the exclusion or limitation of incidental or consequential damages, so the above limitations or exclusions may not apply to you.

This warranty gives you specific legal rights, and you may also have other rights which vary from state to state.

For further information or request for warranty work, please contact: Customer Service  
877 638-9509

All or a portion of this product may be made in China.