



50410 "8" Switch & 50412 "6" Switch

INSTALLATION INSTRUCTIONS

THE 50410 AND 50412 SWITCH PANELS ARE DESIGNED FOR RACING APPLICATIONS. THESE PANELS MAY BE USED FOR STREET APPLICATIONS WITH SOME MODIFICATIONS AND THE ADDITION OF EXTRA FUSED CIRCUITS. IF THE CIRCUIT YOU ARE WANTING TO ADD IS NOT LISTED, PLEASE FEEL FREE TO CONTACT THE PAINLESS TECH LINE FOR ADDITIONAL INFORMATION AND DRAWINGS.

- A. MOUNT THE ENCLOSURE (BOX) IN THE DESIRED LOCATION. YOU MAY CHOOSE TO DRILL AND BOLT THE BOX (BOLTS OR HEAVY DUTY SCREWS ARE RECOMMENDED) TO THE ROLL BAR OR BRACKETS OR WE HAVE INCORPORATED SLOTS IN THE BACK OF THE BOX FOR MOUNTING IT WITH STANDARD HOSE CLAMPS.

NOTE: THE BOX IS PRE-DRILLED TO ALLOW THE WIRES TO EXIT FROM ANY CHOSEN SIDE. THE RUBBER GROMMET IS PROVIDED TO PROTECT THE WIRES AS THEY EXIT THE BOX. CAP PLUGS ARE INCLUDED TO COVER THE REMAINING UNUSED HOLES FOR A FINISHED LOOK.

- B UNROLL THE WIRE HARNESS AND ROUTE ALL THE WIRES OUT THE DESIRED HOLE IN THE BOX THROUGH THE RUBBER GROMMET.
- C ATTACH THE SWITCH PANEL TO THE BOX WITH THE FOUR (4) SCREWS PROVIDED.
- D ROUTE THE WIRES TO THEIR PROPER LOCATION AND TERMINATE USING TERMINALS PROVIDED USING THE FOLLOWING CHART.
- E IF BRAKE LIGHTS ARE TO BE INCORPORATED IN THE VEHICLE, USE THE ATTACHED ILLUSTRATION FOR PROPER WIRE HOOKUP AND PARTS REQUIRED.

**NOTE: * 6 SWITCH PANEL ONLY.
** 8 SWITCH PANEL ONLY.**

WIRE HOOKUP CHART

RED 10 GAUGE TO BATTERY SOURCE

NOTE: YOU MUST INSTALL FUSE HOLDER AND 60AMP FUSE PROVIDED BETWEEN END OF RED WIRE AND BATTERY SOURCE. THIS FUSE HELPS PROTECT THE OVERALL SYSTEM AND IS VERY IMPORTANT.

PURPLE 14 GAUGE TO STARTER SOLENOID

PINK 14 GAUGE TO IGNITION (COIL)

GRAY/WHITE 14 GAUGE TO ELECTRIC FAN

* ORANGE 14 GAUGE TO ACCESSORY

** ORANGE 14 GAUGE TO HORN

YELLOW/WHITE 14 GAUGE TO FUEL PUMP

** LIGHT/GREEN 18 GAUGE TO RIGHT TURN

** LIGHT/BLUE 18 GAUGE TO LEFT TURN

BLUE 14 GAUGE TO WATER PUMP

** BLUE/YELLOW 14 GAUGE TO HEADLIGHTS

** BROWN 14 GAUGE TO TAIL LIGHTS

* WHITE 14 GAUGE TO ACCESSORY

* WHITE 14 GAUGE TO SHOCKS CONTROLLER

WARNING: FAILURE TO USE RELAYS ON FUEL PUMP CIRCUITS AND ELECTRIC FAN CIRCUITS MAY CAUSE PREMATURE SWITCH FAILURE! SEE ATTACHED ILLUSTRATIONS

IMPORTANT: AFFIX LABEL IN AN EASILY SEEN AREA FOR WIRE COLOR CODE CHARTING AND TECH INSPECTION.

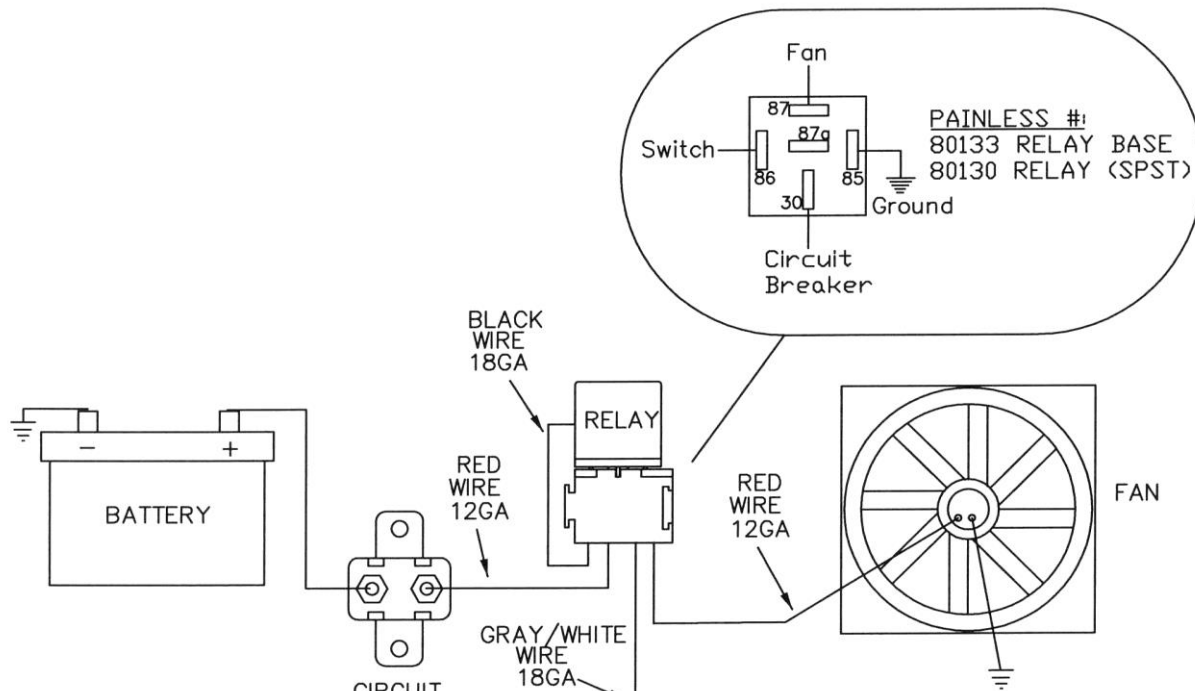

PAINLESS FAN RELAY KIT #30101

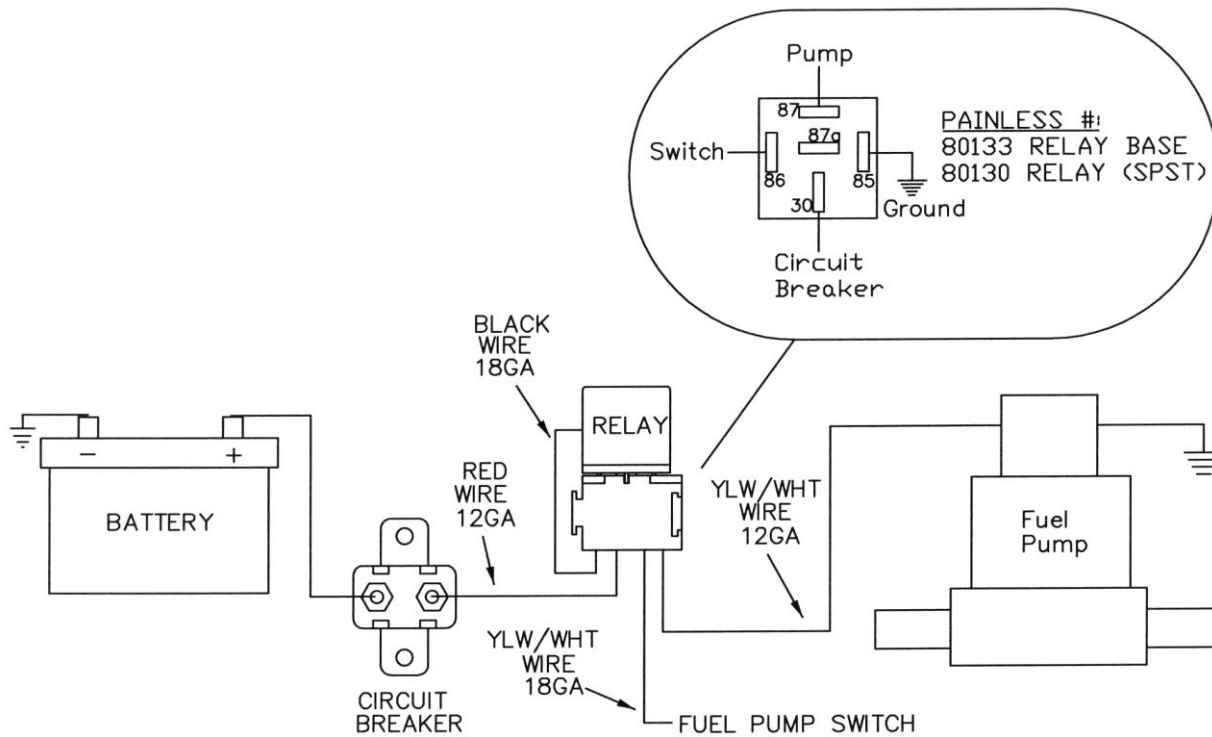

PAINLESS FUEL PUMP KIT #50102

CONNECTING INTEGRATED REAR LIGHTS TO SWITCH PANEL

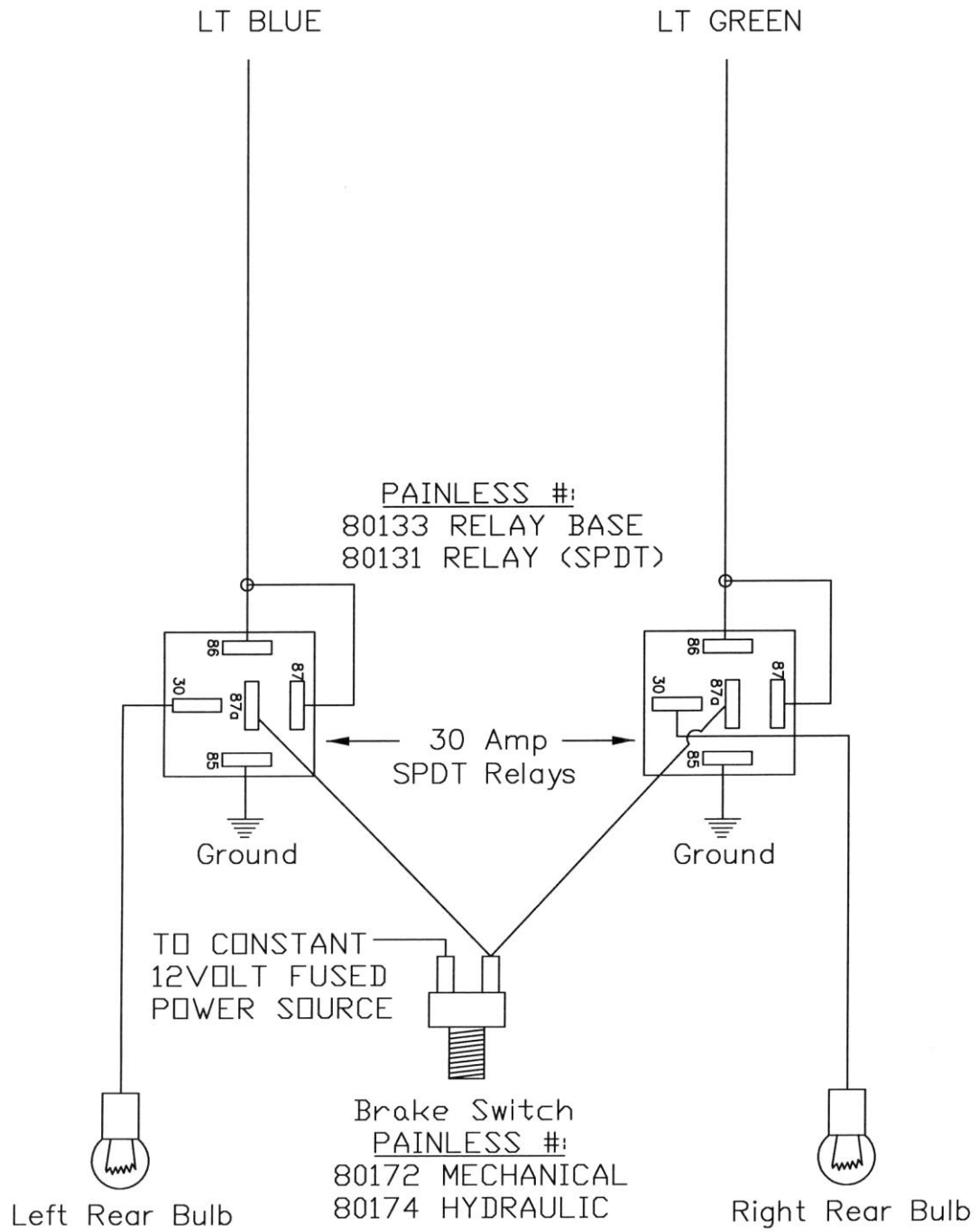

NOTE: ALL WIRES MUST BE 18GA OR LARGER.

Painless Performance Limited Warranty and Return Policy

Chassis harnesses and fuel injection harnesses are covered under a lifetime warranty.

All other products manufactured and/or sold by Painless Performance are warranted to the original purchaser to be free from defects in material and workmanship under normal use. Painless Performance will repair or replace defective products without charge during the first 12 months from the purchase date. No products will be considered for warranty without a copy of the purchase receipt showing the sellers name, address and date of purchase. You must return the product to the dealer you purchased it from to initiate warranty procedures.