



40130

22 PIN BULKHEAD CONNECTOR KIT

This kit contains all the necessary parts to create a weather-proof through panel connection for up to 22 wires. The terminals in this kit are rated at a constant amperage of 20 amps, it is not recommended that charging, headlight, or other high amperage wiring pass through this connector. Doing so may result in damage to the connectors, terminals, and at worse could result in fire. This connector kit is ideal for running turn/brake signal lighting, parking/tail light, gauge wiring, wiper motor, fuel injection, etc.

Take inventory to ensure your kit contains all the parts you will need. If you find that anything is missing or damaged, please contact the dealer where you obtained the kit or Painless Performance at (800) 423-9696. The kit should contain the following:

- | | | |
|------------------------|--------------------------|--------------------------|
| #1 (1) male connector | #2 (1) female connector | #3 (4) connector "combs" |
| #4 (25) male terminals | #5 (25) female terminals | #6 (48) terminals seals |
| #7 (2) nuts | #8 (2) flat washers | #9 (20) cavity plugs |

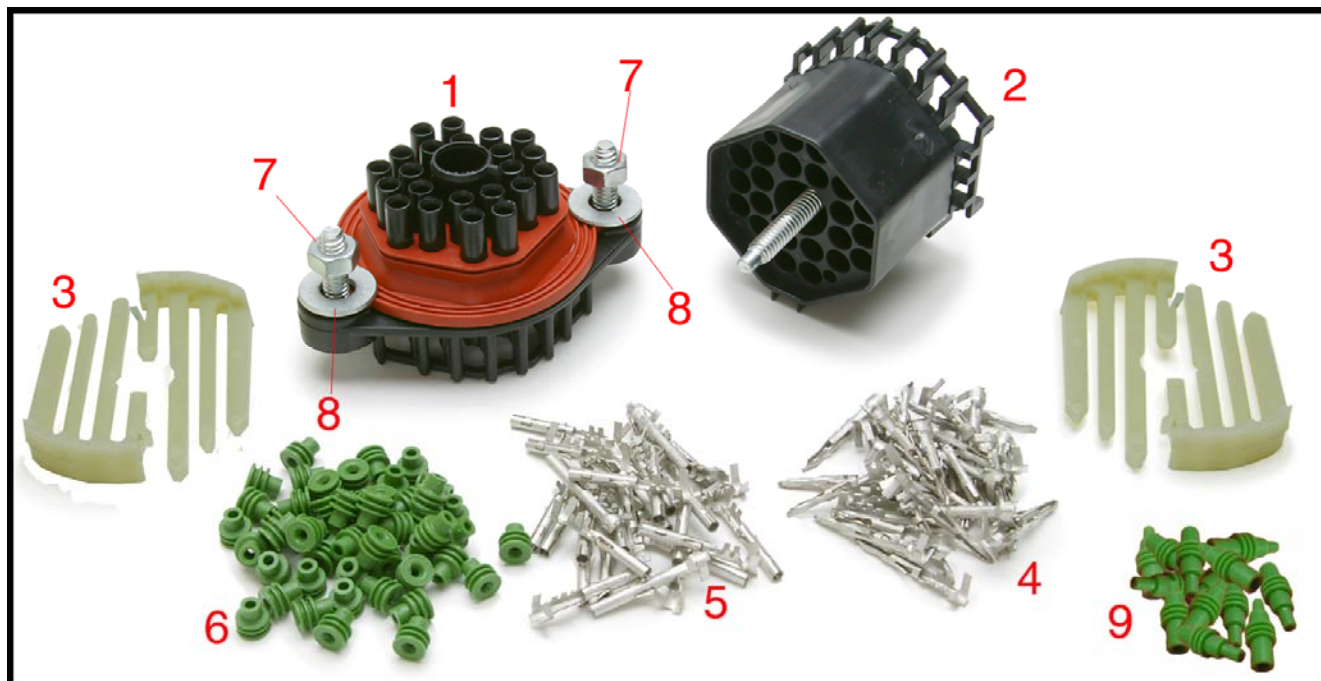

Pin Identification

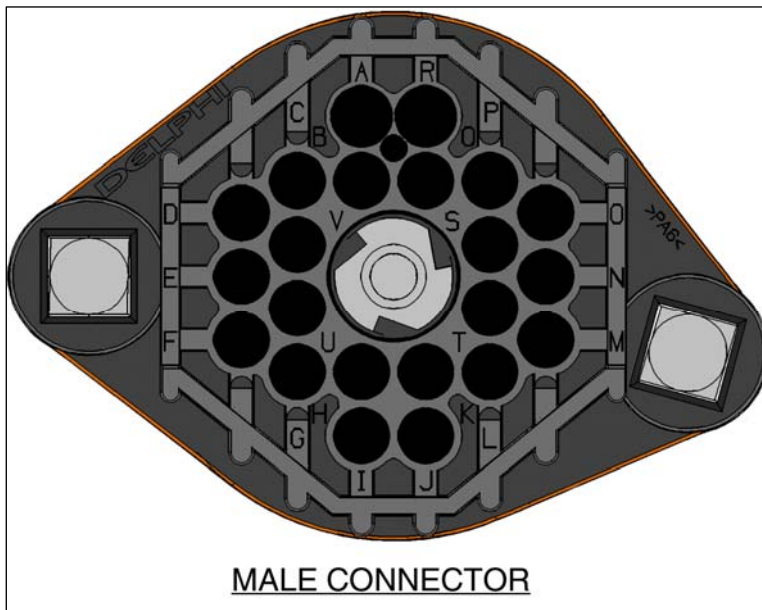
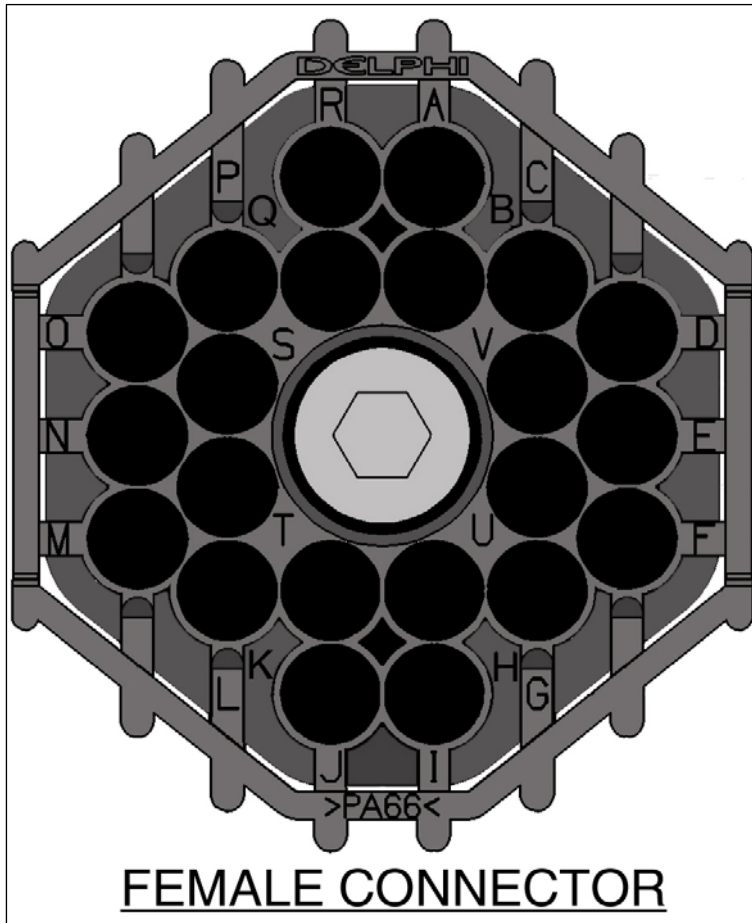

The back side, or wire side, of the connectors, are the sides of the connectors with the head(s) of the bolts showing. Looking at the back side of the connectors, you will see letters identifying each pin.

On the female connector, the connector without the orange weatherproof seal, the pins are lettered in a clockwise order. The top illustration to the left shows the wire side view of the female connector

The male connector, the connector with the seal that has 2 mounting bolts, is lettered counter clockwise. The bottom illustration to the left shows the wire side view of the male connector.

When it comes time to plug wires into the connectors to fit your application, match the wires to pin location. Meaning, Pin A of the male connector will connect to Pin A of the female connector, B will connect to B, C to C, etc. Any unused locations will need to have silicone plugs installed into the cavity. These plugs are identified as #9 in the photo on the first page.

Both connectors are keyed allowing the connectors to only be plugged together one way.

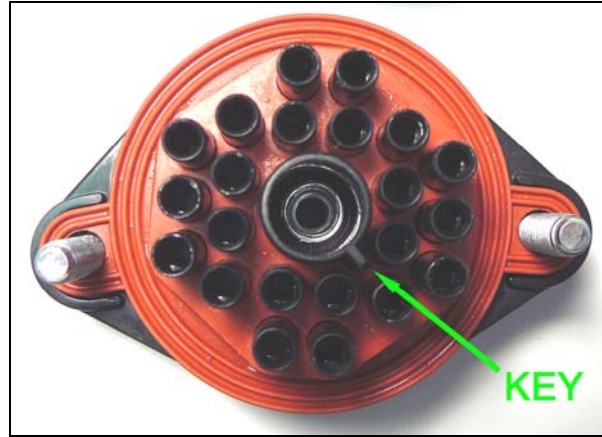

Terminal Installation

The male connector will use the female “socket” type terminal, the terminals labeled #5 in the picture on the first page. The female connector will use the male “pin” type terminal, the terminals labeled #4 in the picture on the first page, also the terminal used in the crimping photos on the following pages.



Crimping the terminals can be broken down into a 5 step process. These steps are:

STEP 1: Seal Installation

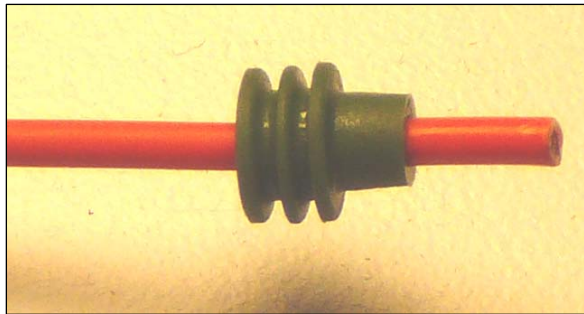

Slide the wire seal over the un-stripped wire as shown in the photo to the left. Doing this over an un-stripped wire will prevent the copper strands of exposed wire from penetrating the inside of the seal making it difficult to slide the seal onto the wire insulation.

STEP 2: Strip Wire

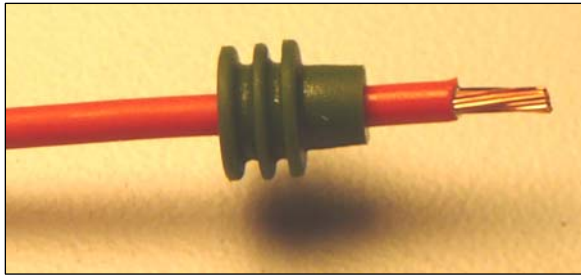

With the wire seal in place, strip no more than $\frac{1}{4}$ " of insulation off of the wire. If your strip length is too long, then the terminal will not fit the wire properly and may not crimp the wire seal when crimping is done. Once you have stripped the wire, slide the seal towards the bare wire.

STEP 3: Terminal Installation

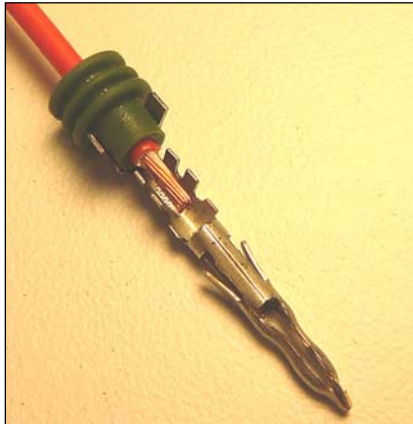

Install the terminal onto the wire as shown in the photo to the left, as well as the photo below. The tall straps found on the rear of the terminal will cradle the small end of the wire seal. The small straps found in the middle of the terminals should cradle the exposed copper of the stripped wire. If things do not fit as shown, you may have too much exposed copper wire or not enough. You will need to adjust your strip length until your terminal, seal, and wire strip resemble those pictured. Failure to do so will result in a bad crimp.

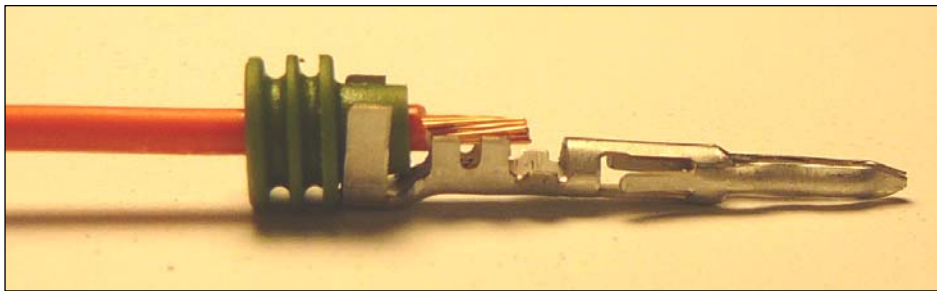

STEP 4: Terminal/ Wire Crimp

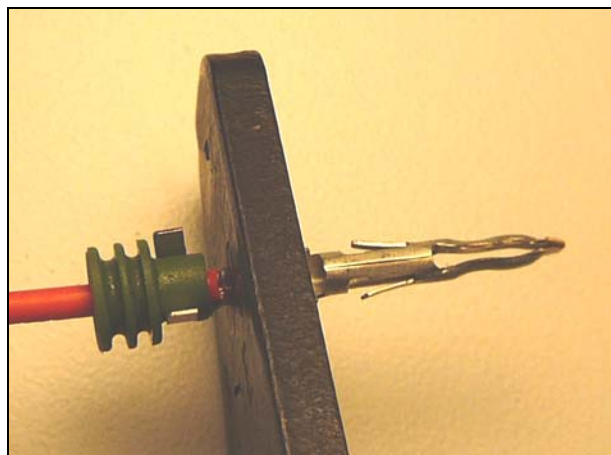
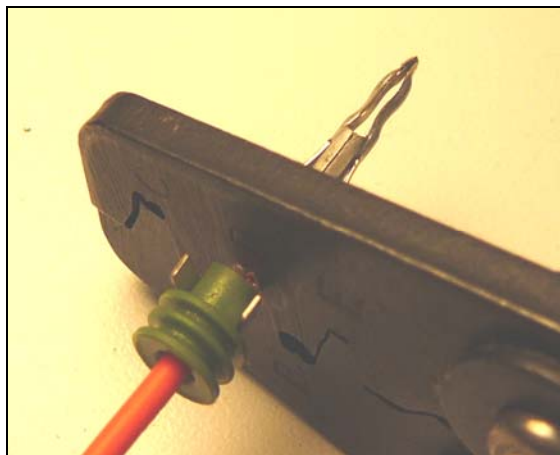

With the proper terminal, wire, and seal alignment established, you can now crimp the

terminal to the exposed copper strands. Using the appropriate jaw location on the crimpers for the gauge wire you are using, crimp the terminal onto the wire. Make sure the crimp causes the terminal to “roll” over and down into the copper wire. In some instances, usually when the wrong jaw size is used, a crimp will cause the terminal straps to fold over on top of each other, this is not a good crimp. The right and wrong crimps are illustrated below. **NOTE:** Avoid over crimping which causes the terminal to distort and will make it difficult to plug into the connector.

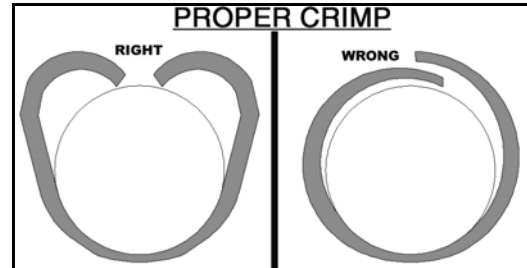
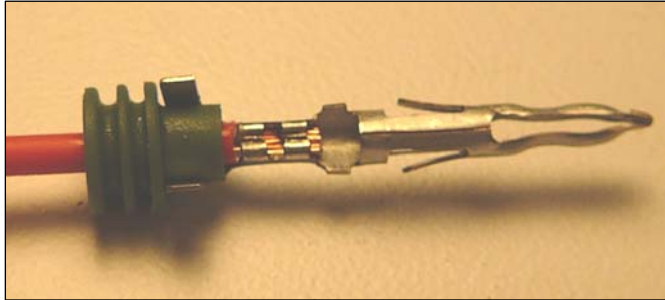

STEP 5: Terminal/ Seal Crimp

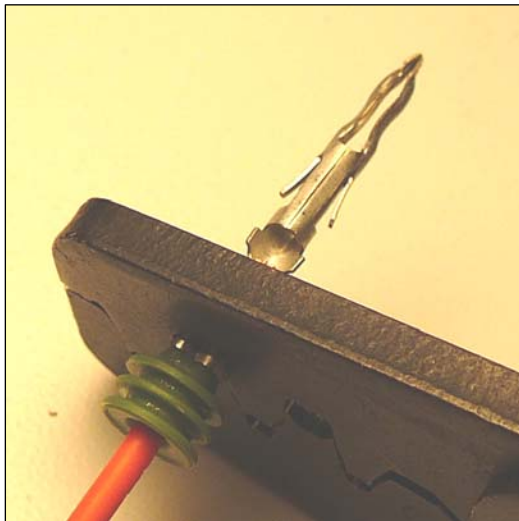

The Terminal/Seal crimp is done in the same manner as the Terminal/Wire crimp. In most cases, depending on your crimpers, this crimp will be done using the largest jaw location on the crimpers. This crimp is simply holding the soft silicone seal to the terminal so not a lot of crimp force is needed. Again, when crimping the seal, make sure you get a “roll” over crimp as shown in the illustration above. Once the seal is crimped, you can now insert the wire and terminal into the correct pin location of the correct connector.

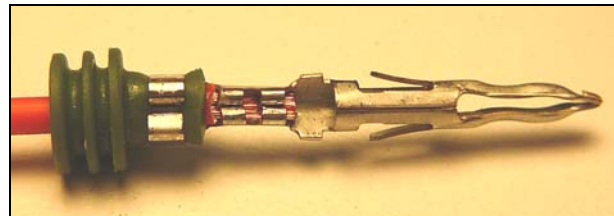
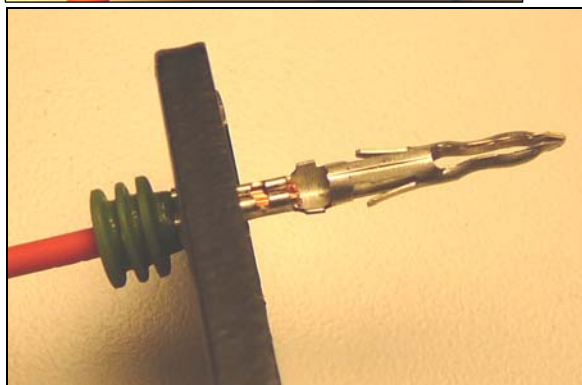

Comb Installation

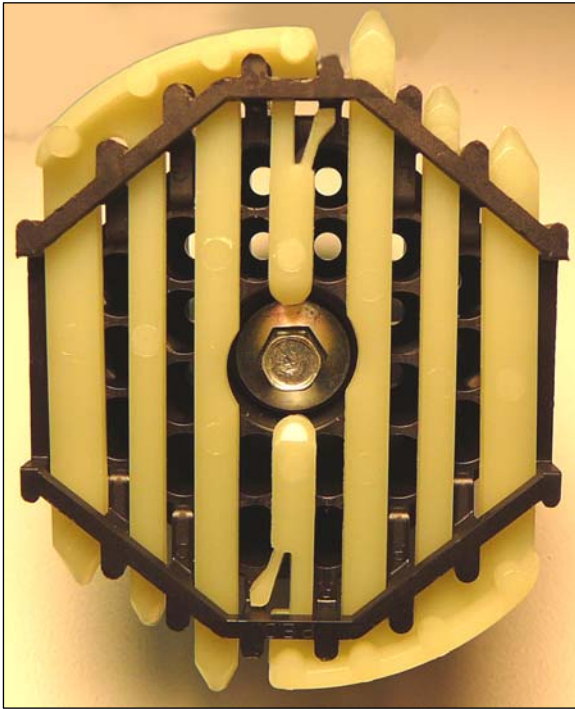

The white “combs” found in the kit are used as a terminal position assurance. These are extra security to ensure the terminals stay in their pin location. These “combs” are installed into the connector only after the wires being used are installed into the connector. Remember, any unused cavities will require a plug to be installed.

Note: The photo to the left shows the “combs” installed without any wires only to represent how they are installed. The photo would not have been as clean and clear with the wires installed.

Connector Mounting

3 holes are necessary for the mounting of the bulkhead connector. A template has been provided on the back page of these instructions to make cutting the holes as easy as possible. When

the holes have been cut, insert the male connector as shown in the illustration below. Nuts and washers have been supplied in order to mount the connector.

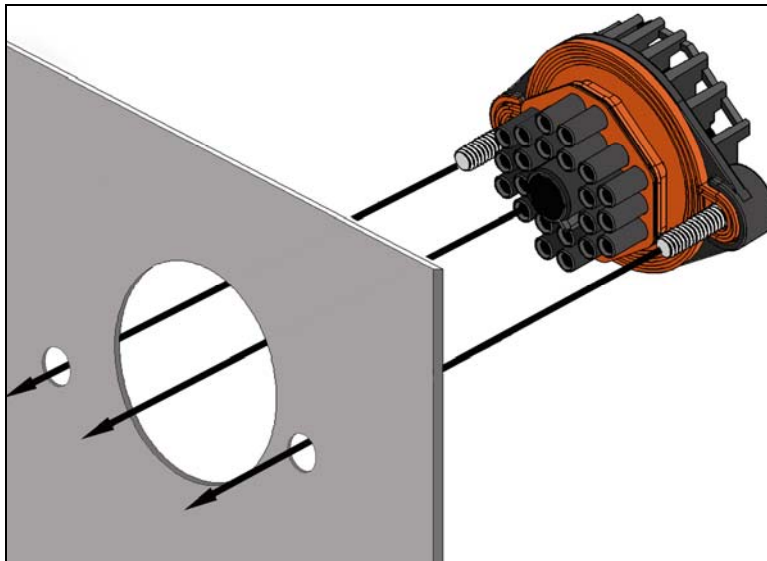

Once the male connector is mounted to the panel, the female connector can now be plugged into it; keeping in mind the connectors are keyed. With the connectors connected, tighten the through bolt found in the center of the female connector. This bolt will give you a secure, positive connection.

Painless Performance Limited Warranty and Return Policy

Chassis harnesses, fuel injection harnesses and Striker Coldshot are covered under a lifetime warranty. All other products manufactured and/or sold by Painless Performance are warranted to the original purchaser to be free from defects in material and workmanship under normal use. Painless Performance will repair or replace defective products without charge during the first 12 months from the purchase date. No products will be considered for warranty without a copy of the purchase receipt showing the sellers name, address and date of purchase. You must return the product to the dealer you purchased it from to initiate warranty procedures.

