



30710

UNIVERSAL COURTESY LIGHT KIT

THIS KIT CONTAINS TWO (2) LIGHT SOCKET ASSEMBLIES WHICH ARE DESIGNED TO MOUNT UNDER THE DASH FOR ILLUMINATION OF THE FRONT SEAT FLOOR AREA OF THE INTERIOR.

MOUNT THE PLASTIC HOUSINGS BY DRILLING A SMALL HOLE (APPROXIMATELY 3/16") IN THE LOWER ROLL OF THE DASH OR KICK PANEL AND MOUNT USING THE SCREWS PROVIDED. THE SCREWS GO THROUGH THE HOLE AND INTO THE HOLE MOLDED INTO THE PLASTIC.

THE WHITE WIRE IS ATTACHED TO YOUR DOME LIGHT POWER LINE (B+) AND THE BLACK TO THE DOME LIGHT GROUND TERMINAL.

THERE ARE BASICALLY TWO DIFFERENT METHODS OF CONNECTING THESE LIGHTS. ONE USES DOOR JAMB SWITCHES WHICH SWITCH THE GROUND. THE OTHER USES DOOR JAMB SWITCHES WHICH SWITCH THE POWER. DEPENDING ON THE MANUFACTURER OF YOUR VEHICLE EITHER OF THE TWO METHODS COULD HAVE BEEN USED.

THIS SIMPLE DIAGRAM ILLUSTRATES THE DOOR JAMB SWITCHES THAT SWITCH THE GROUND. THEY ARE NORMALLY CLOSED TYPE SWITCHES AND WHEN THE DOOR IS CLOSED THEY OPEN THE CIRCUIT TURNING THE LIGHTS OFF.

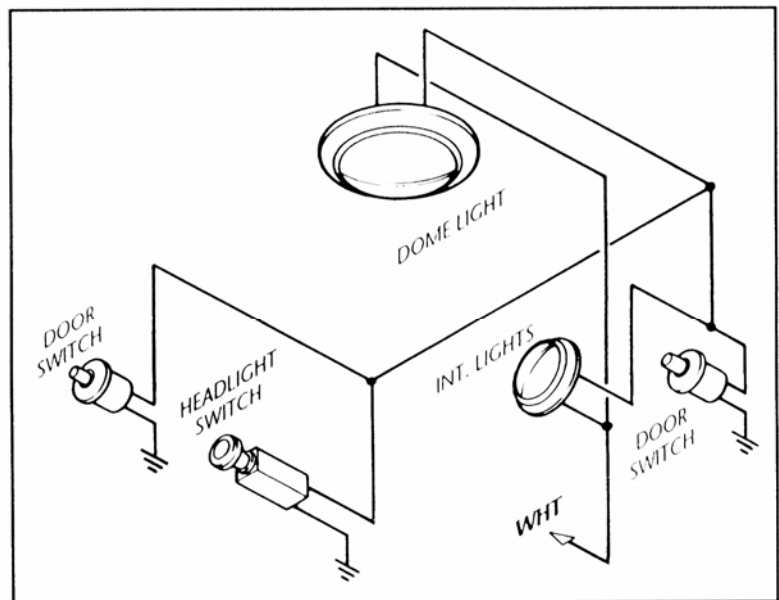

NOTE: BY ATTACHING THE BLACK WIRES OF BOTH LIGHTS TOGETHER, AND THEN TO THE JAMB AND/OR LIGHT SWITCH, BOTH LIGHTS WILL COME ON AT THE SAME TIME.

THIS SIMPLE DIAGRAM ILLUSTRATES THE DOOR JAMB SWITCHES THAT SWITCH THE POWER. THEY ARE NORMALLY CLOSED TYPE SWITCHES AND WHEN THE DOOR IS CLOSED THEY OPEN THE CIRCUIT TURNING THE LIGHTS OFF.

