

CAUTION: BEFORE THE REMOVAL OF YOUR ORIGINAL HARNESS AND/OR THE INSTALL OF YOUR NEW PAINLESS HARNESS, DISCONNECT THE POWER FROM YOUR VEHICLE BY REMOVING THE NEGATIVE OR POSITIVE BATTERY CABLE FROM THE BATTERY.

- If your vehicle has an existing harness, you will want to retain it for the possible re-use of various pigtails and connector housings particular to your application. During the removal process, avoid making any unnecessary cuts.
- This harness is universal in nature. This means most/all ends are left open to allow you to cut each wire to length and make the appropriate connection. The small parts package and the bag kits with terminals and connectors included with the harness will enable you to make connections.
- Only printed wires have a 900-series number. These 900-series numbers are used to identify various wires and circuits in the wiring diagrams that are a part of these instructions.
- This harness will not support the use of a factory or aftermarket Ammeter.

If there are unused or unconnected wires, they will need to have their ends terminated with an insulated terminal or electrical tape. Doing so will prevent the wires from shorting and causing harness failure or fire.

TABLE OF CONTENTS

<u>PAGE #</u>	<u>SECTION</u>
1	<u>INTRODUCTION</u>
2	<u>CONTENTS</u>
4	SMALL PARTS
5	<u>TOOLS NEEDED</u>
6	<u>TO REMOVE A TERMINAL</u>
7	<u>INSTALLING FACTORY STYLE TERMINALS</u>
8	<u>GROUNDS</u>
9	WHY ARE CLEAN GROUNDS IMPORTANT?
11	<u>FUSE BLOCK</u>
11	HORN RELAY
11	FLASHERS
12	FUSE IDENTIFICATION
13	RELAYS & SWITCHES
15	<u>OLD FACTORY HARNESS REMOVAL</u>
16	<u>PRE-INSTALLATION GUIDELINES</u>
20	<u>FIREWALL PASS-THRU</u>
20	ENGINE/HEADLIGHT WIRING
20	SINGLE HOLE
20	TWO HOLE
22	<u>FUSE BLOCK MOUNTING</u>
22	FIREWALL MOUNTING W/O A FACTORY BULKHEAD CONNECTOR
23	BRACKET MOUNTING THE FUSE BLOCK
24	<u>HARNESS ROUTING</u>
25	ON THE INSIDE OF THE VEHICLE
26	<u>FRONT LIGHT SECTION</u>
26	LEFT / DRIVER SIDE HEADLIGHT
27	3-prong, Sealed Beam/Sealed Beam Halogen/ H4 Halogen
29	Headlights with Pigtails
31	LEFT PARK / SIDE MARKER LIGHT
33	LEFT TURN / PARK LIGHT
34	HORN
34	ACCESSORY / FAN RELAY
35	RIGHT TURN / PARK LIGHT & HEADLIGHT
37	<u>ENGINE SECTION</u>
38	BRAKE SWITCH (Hydraulic)
39	COOLANT TEMP SENSOR
40	OIL PRESSURE SENSOR
41	ELECTRIC CHOKE
42	Turbo 400 Transmission
43	COIL
44	Tachometer
47	A/C COMPRESSOR CLUTCH
48	<u>START / CHARGE SECTION</u>
49	ALTERNATOR
51	CHARGE INDICATOR LIGHT

Continued...

TABLE OF CONTENTS

<u>PAGE #</u>	<u>SECTION</u>
52	GM SI SERIES ALTERNATORS
53	GM CS-130 SERIES ALTERNATORS
55	GM CS-130D SERIES ALTERNATORS
57	GM EXTERNALLY REGULATED ALTERNATOR
58	FACTORY GENERATORS
59	FORD EXTERNALLY REGULATED ALTERNATORS
60	Method #1
60	Method #2
61	FORD 3G ALTERNATOR
63	MOPAR EXTERNALLY REGULATED ALTERNATOR
63	Mechanical Regulator
64	Electrical Regulator
65	MIDI FUSE
66	STARTER SOLENOID
66	10201 & 10203
67	10202 & 10204
69	Mopar Starter Relays
71	<u>INTERIOR HARNESS</u>
72	<u>DIMMER SWITCH</u>
74	<u>HEADLIGHT SWITCH</u>
76	GM HEADLIGHT SWITCH
77	FORD HEADLIGHT SWITCH
77	CHRYSLER HEADLIGHT SWITCH
78	PAINLESS UNIVERSAL HEADLIGHT SWITCHES
79	TOGGLE / ROCKER HEADLIGHT SWITCH
80	<u>BRAKE SWITCH</u>
82	<u>TURN SIGNAL SWITCH</u>
84	GM COLUMNS / AFTERMARKET GM STYLE COLUMNS
85	FORD COLUMNS
87	MOPAR COLUMNS
88	EXTERNAL / CLAMP-ON COLUMN MOUNTED SWITCH
89	SPDT TOGGLE SWITCH
90	HAZARD SWITCH
91	HORN BUTTON
92	<u>IGNITION SWITCH</u>
93	GM COLUMN MOUNTED (PRE-TERMINATED ON 10201 & 10203)
94	GM DASH MOUNTED (10202 & 10204)
96	FORD KEY ON THE DASH
96	PAINLESS UNIVERSAL IGN. SWITCH - #80153
97	<u>REVERSE SWITCH</u>
98	CRUISE CONTROL SWITCH
98	4L60E/4L80E SWITCH
100	<u>NEUTRAL SAFETY / CLUTCH SWITCH</u>
100	10201 & 10203
100	Aftermarket Floor Shifter

Continued...

TABLE OF CONTENTS

<u>PAGE #</u>	<u>SECTION</u>
101	10202 & 10204
102	Aftermarket Floor Shifter
103	<u>DRIVER DOOR SECTION</u>
104	<u>INSTRUMENT PANEL</u>
105	FACTORY PRINTED CIRCUIT GAUGES
106	AFTERMARKET GAUGES
106	SEPARATE HARNESS - PAINLESS #30301 & 30302
108	HARDWIRING
113	<u>RADIO & ACCESSORIES</u>
114	RADIO
115	ACCESSORY SECTION
115	Wiper Switch
115	A/C – Heat Switch
115	Factory Heater or A/C Harness
118	Fan Relay Activation Using #906 Accessory Power (Ign.)
119	Cigarette Lighter / Power Port
119	If you have a Clock
120	<u>PASSENGER DOOR SECTION</u>
121	<u>TAIL SECTION</u>
121	DOME LIGHT
122	TRUNK LIGHT
122	POWER ANTENNA
123	LEFT SIDE MARKER LIGHT
124	LEFT TURN / BRAKE LIGHTS
125	LEFT TAILLIGHT
125	LEFT REVERSE LIGHT
126	FUEL SECTION
126	Fuel Sender
127	Fuel Pump
128	LICENSE PLATE LIGHT
128	RIGHT TURN/ BRAKE/ REVERSE/ MARKER LIGHTS
131	<u>TESTING THE SYSTEM</u>
132	<u>WIRE INDEX</u>

SCHEMATICS

<u>PAGE #</u>	<u>SECTION</u>
13	12 VOLT SOURCE ACTIVATION
14	GROUND ACTIVATION
14	FAN RELAY GROUND ACTIVATION
30	STREET ROD "BUCKET" STYLE HEADLIGHTS
32	SIDE MARKER LIGHTS
35	FAN RELAY 12 VOLT SOURCE ACTIVATION
35	FAN RELAY GROUND ACTIVATION
36	FRONT LIGHT SECTION
38	ENGINE SECTION
42	CHOKE & TH400 TRANSMISSION
45	COIL CONNECTIONS (NO BALLAST RESISTOR)
45	BALLAST RESISTOR CONNECTIONS
46	HEI COIL ON CAP CONNECTIONS
46	MSD IGNITION CONNECTIONS
48	CHARGE / BATTERY POWER
51	CHARGE INDICATOR LIGHT
52	10-SI ALTERNATOR
54	CS-130 ALTERNATOR
56	CS-130D ALTERNATOR
57	EXTERNAL VOLTAGE REGULATOR
58	GENERATOR CHARGING SYSTEM
59	FORD EXTERNAL VOLTAGE REGULATOR
62	FORD 3G ALTERNATOR
62	FORD 2G ALTERNATOR
63	MOPAR EXTERNAL REGULATOR (pre-1970)
64	MOPAR EXTERNAL REGULATOR (1970+)
67	GM STARTER CONNECTIONS
68	FORD CHARGE/BATTERY POWER SCHEMATIC
68	FORD STARTER SOLENOID
69	MOPAR STARTER RELAY
70	SR14 RELAY
73	HEADLIGHT DIMMER SWITCH
73	FORD HEADLIGHT DIMMER SWITCH
75	HEADLIGHT SWITCH & DIMMER SWITCH
76	EARLY STYLE GM HEADLIGHT SWITCH (also PAINLESS #80152)
76	LATER STYLE GM HEADLIGHT SWITCH
77	FORD STYLE HEADLIGHT SWITCH
77	CHRYSLER STYLE HEADLIGHT SWITCH
78	PAINLESS HEADLIGHT SWITCH #80151
78	PAINLESS HEADLIGHT SWITCH #80154
79	NON-LIGHTED SPST TOGGLE/ROCKER HEADLIGHT SWITCH
79	LIGHTED SPST TOGGLE/ROCKER HEADLIGHT SWITCH
81	TURN SIGNAL SWITCH & BRAKE SWITCH
86	FORD "SEMI CIRCLE" TURN SIGNAL SWITCH CONNECTOR
86	FORD TURN SIGNAL CONNECTOR (W/O HAZARD)
88	EXTERNAL / CLAMP-ON COLUMN MOUNTED SWITCH
89	TOGGLE SWITCH TURN SIGNAL
90	3PST ON-OFF HAZARD SWITCH
90	SPST ON-OFF HAZARD SWITCH (BRAKES ONLY)
93	COLUMN MOUNTED GM IGNITION SWITCH (10201 & 10203)
94	'55 - '57 CHEVY IGNITION SWITCH PINOUT

Continued...

SCHEMATICS

<u>PAGE #</u>	<u>SECTION</u>
94	EARLY 60s GM DASH MOUNTED IGNITION SWITCH SCHEMATIC
95	MID TO LATE 60s GM DASH MOUNTED IGNITION SWITCH
95	'67-'72 GM TRUCK DASH MOUNTED IGNITION SWITCH SCHEMATIC
96	FORD DASH MOUNTED IGNITION SWITCH
96	PAINLESS UNIVERSAL IGNITION SWITCH #80153
99	EARLY 4L60e/4L80e NSS/REVERSE SWITCH
99	LATER 4L60e/4L80e NSS/REVERSE SWITCH
107	30301 or 30302 CONNECTOR PINOUT
108	POWERING AFTERMARKET GAUGES (SPLICING)
108	POWERING AFTERMARKET GAUGES (CHAINING/JUMPING)
109	GROUNDING AFTERMARKET GAUGES (SPLICING)
109	GROUNDING AFTERMARKET GAUGES (CHAINING/JUMPING)
110	AFTERMARKET GAUGE LIGHT POWER (SPLICING)
110	AFTERMARKET GAUGE LIGHT POWER (CHAINING/JUMPING)
111	AFTERMARKET GAUGE SENDER WIRES
112	INSTRUMENT PANEL
113	RADIO & ACCESSORY SECTION
116	TYPICAL GM HEATER ONLY SYSTEM
116	A/C SYSTEM w/ BINARY SAFETY SWITCH
117	A/C SYSTEM w/ TRINARY SAFETY SWITCH
118	FAN RELAY 12 VOLT SOURCE ACTIVATION
118	FAN RELAY GROUND ACTIVATION
123	REAR SIDE MARKER
129	TAIL SECTION W/ INTEGRATED TURN/BRAKE LIGHTS
130	TAIL SECTION W/ SEPARATE TURN/BRAKE LIGHT

INTRODUCTION

Thank you for your purchase of a Painless Performance Products harness. This is a customizable harness; therefore, we suggest you retain your original harness for any unique plugs or connectors you may need while installing your new harness.

The fuse block is pre-terminated, and the proper fuses for each circuit are pre-installed. All wires are colored based on GM color codes. Also, each wire is marked with a 900-series wire number, what section the wire is in, and the wire's function. These 900-series numbers are assigned by Painless and do not correspond to any circuit numbers found on any factory wiring schematics. A **Wire Index** is located on [page 132](#) and provides a quick reference guide for the individual wires of this harness. The Wire Index identifies the gauge, color, what is printed on the wire, and point of origin for each wire.

During this manual, you will notice wires with a slash (Ex. **BLUE/WHITE**). This indicates a wire with a stripe. The first color listed is the main wire color, and the second color will reference the stripe color. Therefore, the **BLUE/WHITE** example will be a **BLUE** wire with a **WHITE** Stripe.

Do not let the length of this instruction manual intimidate you. Much of the information contained in this manual is helpful information about each wire, where the wire comes from, where it goes, why a component needs it, etc. In many cases, there are multiple schematics as well as alternate connection options for the same wire/connection point due to this being a customizable harness. You will find that the actual install portions of this manual are straightforward and easy to follow.

Individual components and sections are tied together for easy routing of the harness. GM color-coded wires, along with the schematic diagrams found throughout this manual and the printed circuit numbers and description printed on the wire, will help you identify the different circuits during installation and later on if additions to the overall system are necessary.

As you read through this installation manual, prior to installing your new harness, you will find blank areas titled **NOTES** in each section and the back of the manual. You may find these sections beneficial for taking notes, listing components you are connecting to on your vehicle, and the factory or manufacturer wires that are coming from the component. You can then use the text in the manual and the wire index in the back of the manual to identify the wire and circuit number in the Painless harness that will connect to that requirement. For example, a turn signal switch for a 1966 Impala:

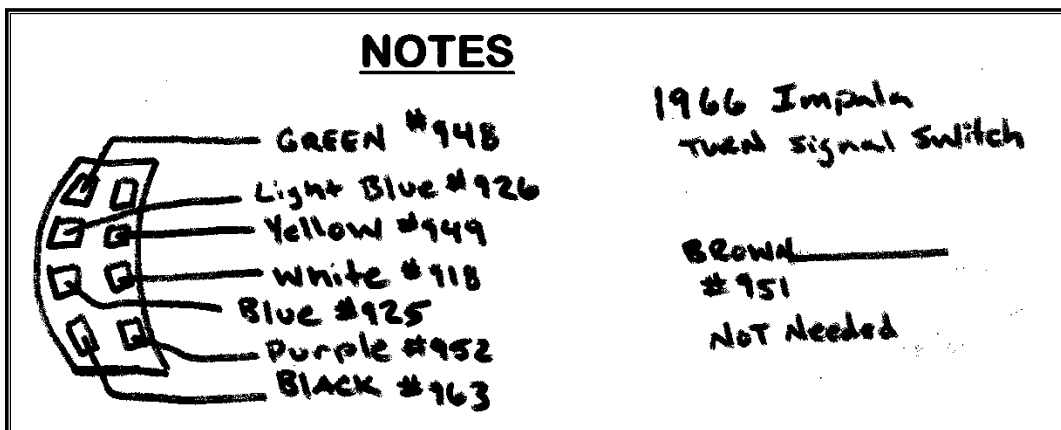

CONTENTS

Refer to the **Contents Figure** (below) to take inventory. See that you have everything you are intended to have in this kit. If you find that anything is missing or damaged, please contact the dealer where you obtained the kit or Painless Performance at (800) 423-9696.

The Classic Customizable harnesses come with two main options/differences. Option one is going to be pre-terminated for a GM Column ignition switch connector (10201 for cars or 10203 for trucks). Option two will contain all the ignition switch wiring but will not be pre-terminated for a GM Column (10202 for cars and 10204 for trucks).

The Painless Wire Harness Kits 10201 and 10203 should contain the following:

- Pre-terminated fuse block and harness.
- Pre-terminated ignition switch wiring for GM key on column vehicles.
- Parts Kits: (1) insulated loose piece terminals kit (1) un-insulated terminal kit
- 2 bag kits: Alternator bag & a small parts bag
- This manual: 90626

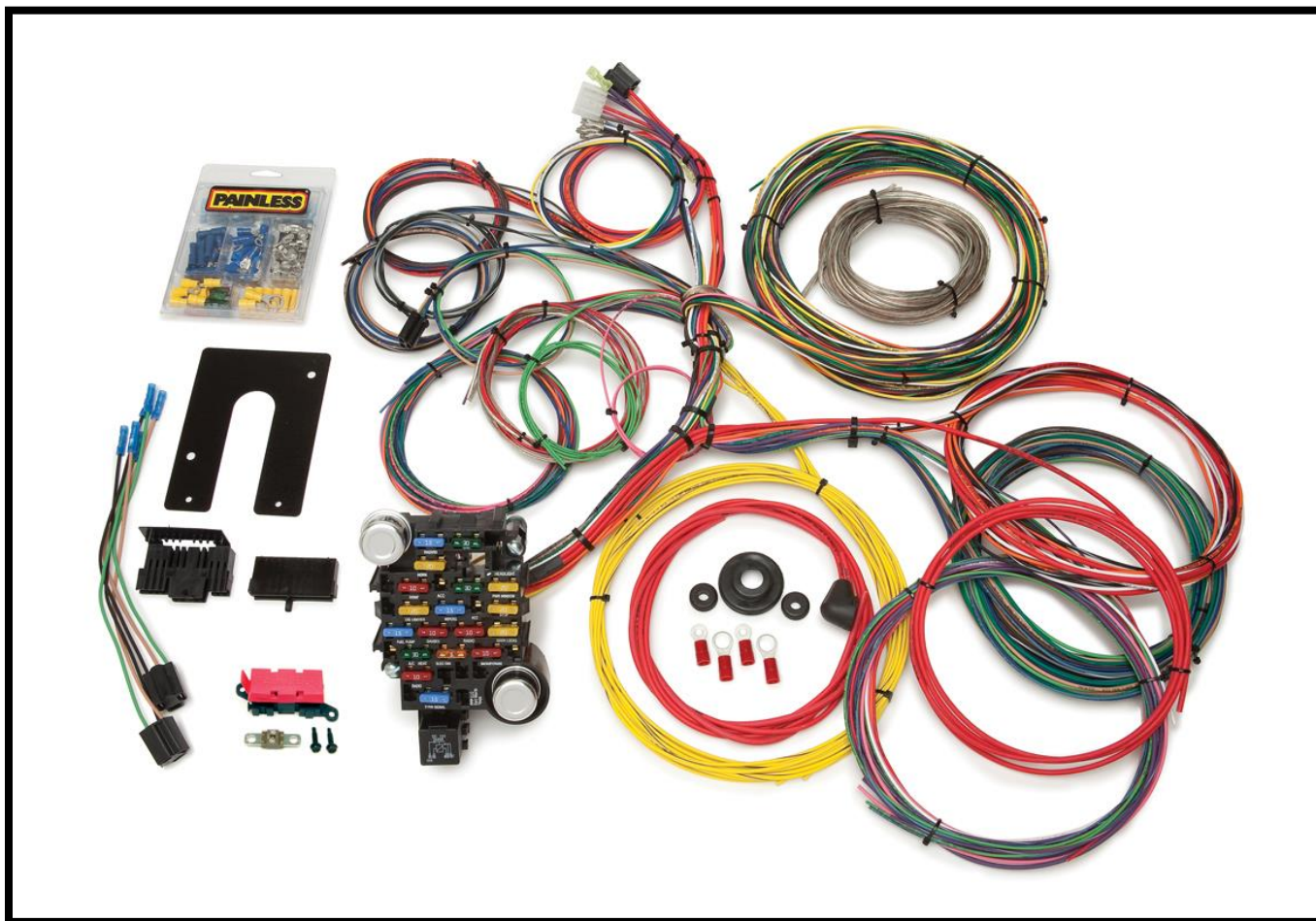

The Painless Wire Harness Kits [10202](#) and [10204](#) should contain the following:

- Pre-terminated fuse block and harness.
- Parts Kits: (1) insulated loose piece terminals kit (1) un-insulated terminal kit
- 2 bag kits: Alternator bag & a small parts bag
- This manual: 90626

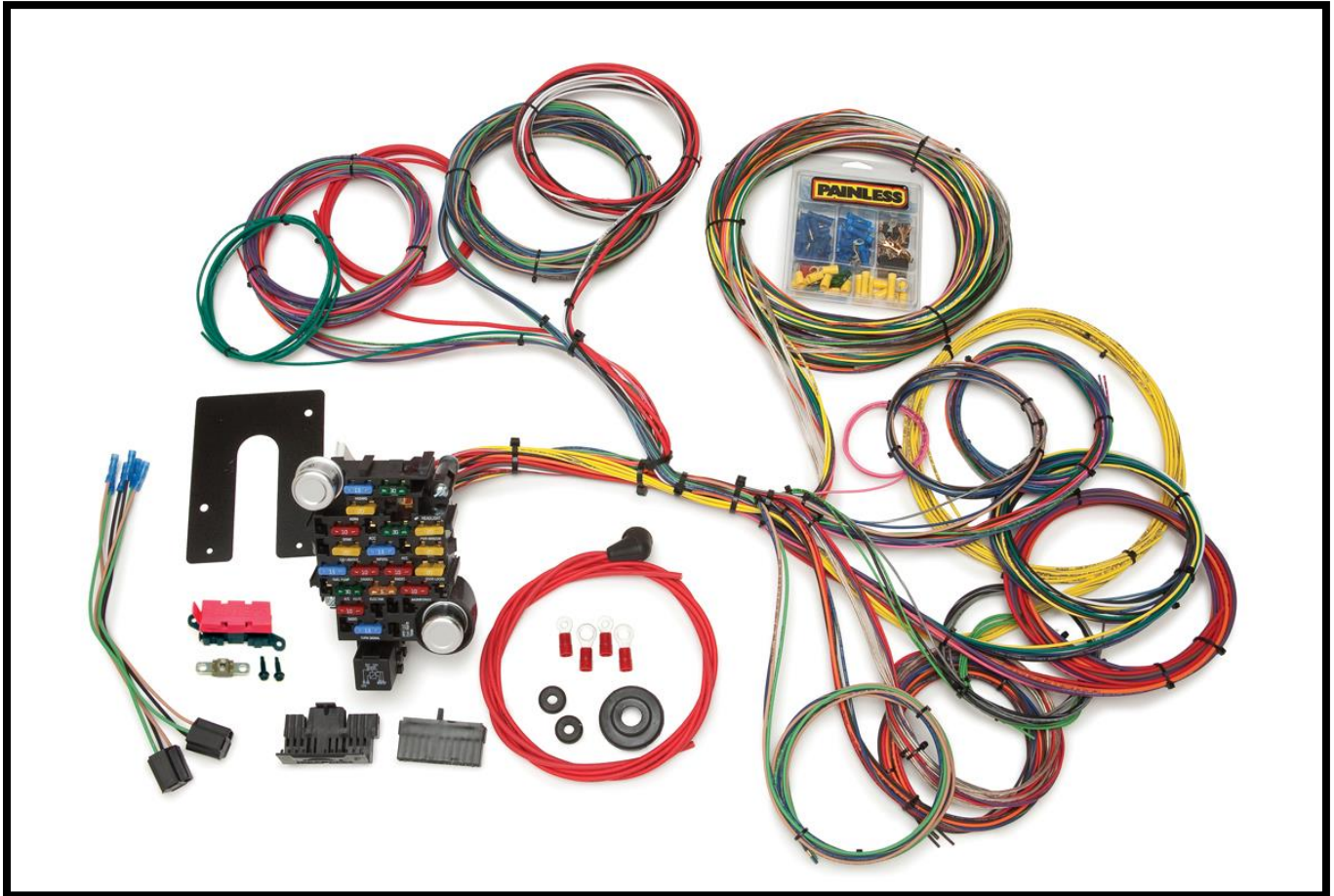

SMALL PARTS

This Painless harness includes several parts kits containing a variety of terminals, fuses, and screws. Many of the terminals are non-insulated and require heat shrink to be applied after the terminal is properly crimped. Heat shrink is supplied with this kit.

These non-insulated terminals allow you to keep a cleaner, more factory look; colored insulated terminals can look out of place. When crimping these terminals, take notice of the split in the terminal. Always make sure the split in these non-insulated terminals is facing the groove.

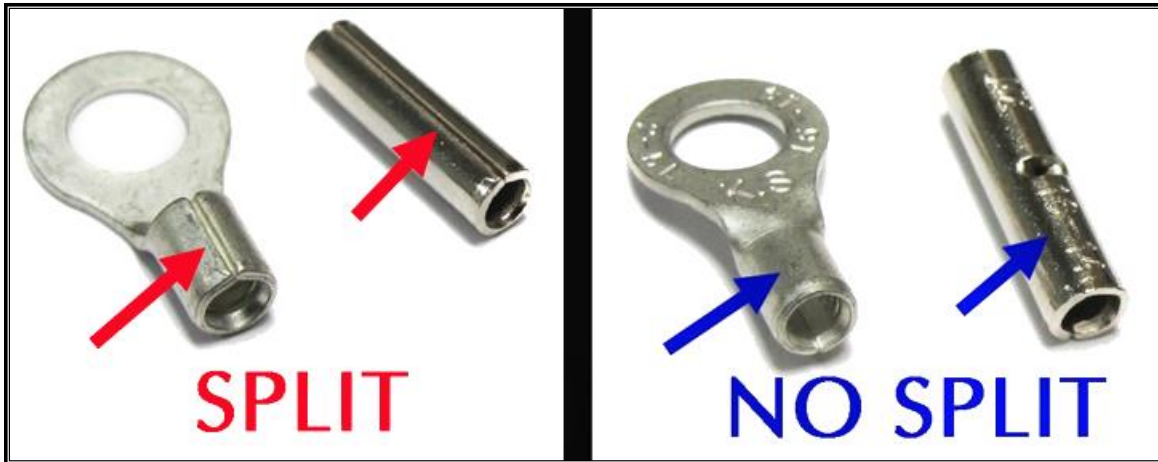

TOOLS NEEDED

In addition to your regular hand tools, you will need, at least, the following tools:

- **Wire Crimping and Stripping Tools:**

This style of hand crimper can be purchased from just about any local auto parts store, home improvement store, or can also be purchased online. You will need this style of crimper to crimp the heat shrinkable and non-heat shrinkable, insulated terminals included in the small parts kit.

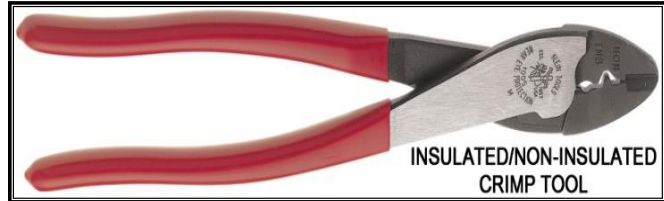

Another style of crimpers is “Jaw Crimpers” or “Roll-Over Crimpers.” These crimpers will crimp factory style, non-insulated terminals. These types of terminals are provided in the kit for connecting to an HEI distributor, headlights, and a factory-style alternator. Painless offers “Jaw Crimpers,” such as those seen to the right, under [Painless part #70900](#).

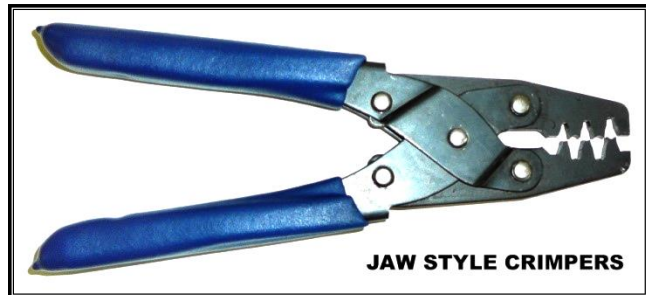

A good set of wire strippers is required to strip wire properly. This style of wire stripper is ideal for this harness install because of its ability to properly strip wire gauges 10 to 20. These are available from just about any local auto part store, electrical supply shop, home improvement store, or can be purchased online.

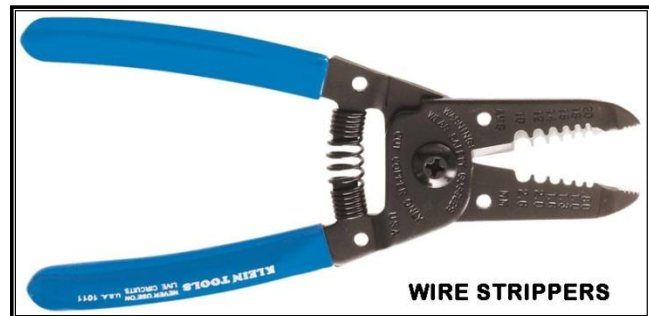

- **Volt/Ohm Meter:**

A Volt/Ohm meter is always a good tool to have on hand when installing any type of electrical components in a vehicle. Most basic units provide the two functions required to diagnose electrical issues seen during a harness install. These two functions are the ability to read DC Voltage and electrical continuity or Ohms. They can be purchased from any home improvement store, local hardware store, electrical supply shop, and online.



PLEASE DO NOT RELY ON USING A TEST LIGHT.

- **Electric Drill & Drill Bits:**

A drill and bits are needed to mount the MIDI fuse holder and the fuse block. Additionally, a $\frac{1}{4}$ " **drill bit** is required to mount the "umbrella" style zip-ties provided with the kit.

- **Heat Gun:**

Particularly useful to shrink the heat-shrinkable terminals found in the parts kit.

- **Factory Wire Schematic**

This is not necessary; however, having one handy is good practice with any electrical job.



TO REMOVE A TERMINAL



- Notice the locking tang that holds the terminal in the connector. Locate the tang access slot on the terminal end of the connector. Push a paper clip, stiff wire, or a small flat head screwdriver into the slot to depress the locking tang on the terminal.
- Once depressed, pull the harness wire from the connector. Do not pull too hard or you could pull the wire out of the terminal; this leaves the terminal stuck in the connector.

INSTALLING FACTORY STYLE TERMINALS

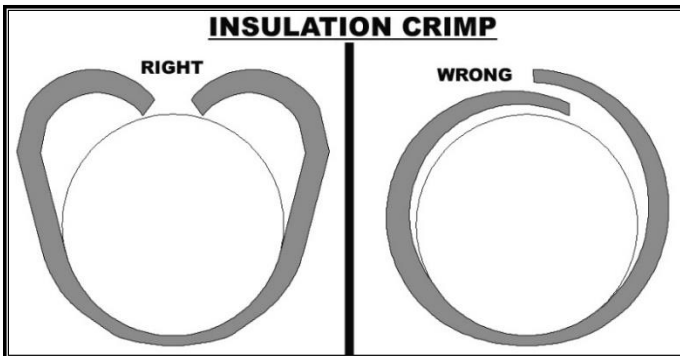
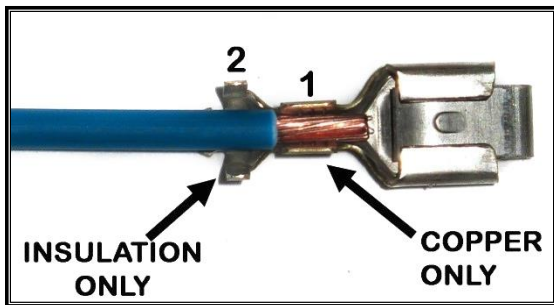

In the parts kit, you will see different uninsulated male and female terminals. These terminals are for factory-style connections and require rollover crimpers.

- Strip about $\frac{1}{4}$ " of insulation off the wire.
- Insert the wire into the terminal. There are two terminal straps on the terminal. For instructional purposes, we will label them 1 and 2. Strap 1 crimps the exposed copper strands of the wire, while strap 2 crimps the wire insulation. Make your strip length long enough to ensure only copper strands are crimped by Strap 1 but short enough that only insulation is crimped by Strap 2. The photo to the left best demonstrates this.
- Using the appropriate jaw on the crimpers, crimp Strap 1. The appropriate jaw depends on the wire gauge as well as the terminal stiffness. If you are unsure which jaw to use, you can always start with the biggest and work your way down until you get a tight crimp.
- With Strap 1 crimped, move onto crimping the insulation strap: Strap 2. Place Strap 2 into the appropriate jaw of the crimpers. This jaw will be larger than the one used to crimp the first strap. Crimp down on Strap 2 making sure the strap folds down into the wire, and not overlapping itself. Refer to the drawing to the left. Overlapping could cause problems with the terminal fitting into the factory connector.

GROUNDS

Throughout this instruction manual, and when looking at the Painless harness, you will see the word GROUND. Maybe you have seen the ground symbol on wiring diagrams before? What exactly is a ground and why do you need it?

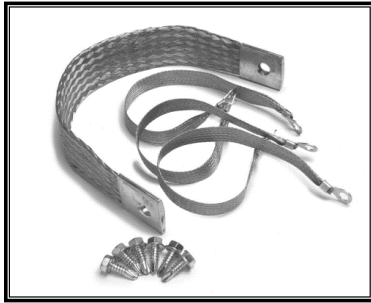
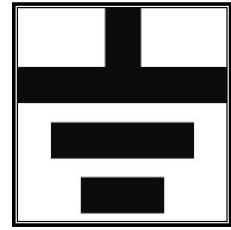

You have probably noticed the large cable coming from the negative side of your battery going down to the frame or the engine. This cable allows voltage to get back to the battery through the metal of the frame and all the other metal pieces bolted to the frame. It is also important to have ground cables going from the frame to the engine and from the frame to the body.

A ground is simply the common path electrical current follows back to the battery. A ground, or chassis ground as it is often called, is any bare metal surface found on the vehicle which is in turn connected back to the frame/negative side of the battery through mounting points and ground straps. Grounds are needed for the electrical current to complete the circuit.

There are two ways components are grounded in vehicles: through mounting or a wired connection.

Some grounds are supplied through mounting of the metal housings in which bulbs are installed, like turn signal or taillight housings. Components with plastic housings or non-conductive housings, like headlights which are glass, get their grounds through wires from the chassis harness.

Make sure all mounting points are clean by removing any dirt, corrosion, and/or paint. This includes light housings that ground through mounting them and the harness ground wire connection point. This is especially important for cars that have recently been painted as paint build-up will cause grounding issues. 80 grit or courser sandpaper should be all that is needed to properly clean grounding points.

GROUND STRAPS

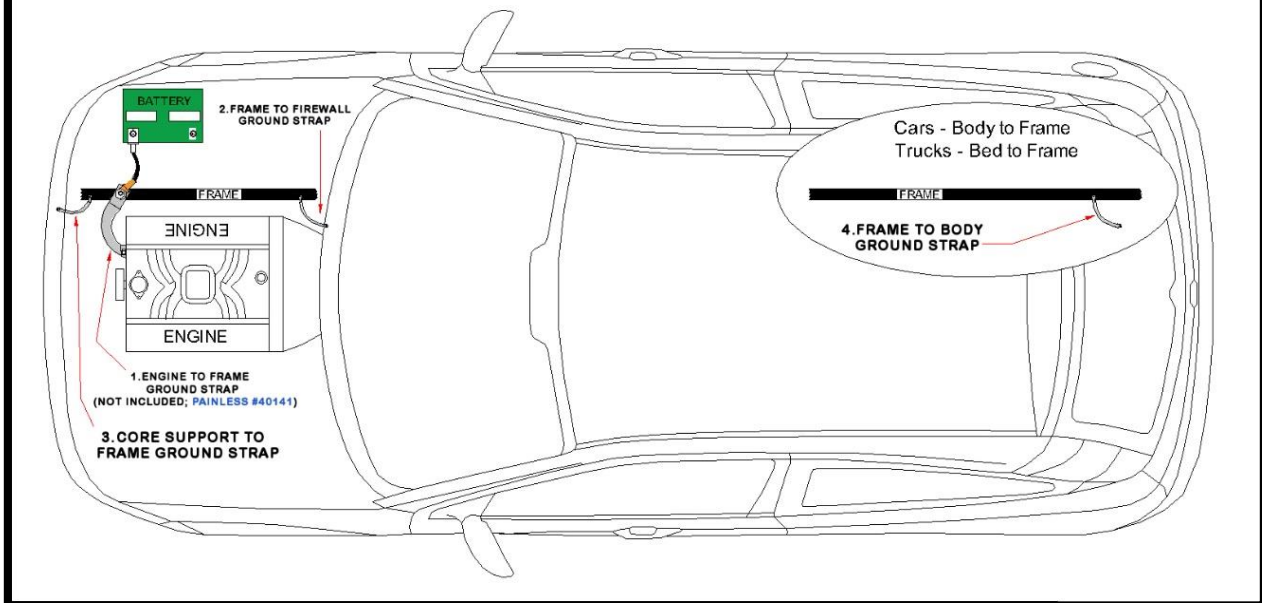

WHY ARE CLEAN GROUNDS IMPORTANT?

As an example, we will use a front turn signal that also functions as a park light. Follow the red line from right to left in the diagram below. This red line indicates the path the electrical current takes when everything is properly grounded. The diagram on the next page represents when the ground is bad. Notice which bulbs illuminate when good and bad grounds are present.

In our park light example with a good ground source, current travels from the headlight switch to the park light bulb element. Since the bulb is properly grounded, the current passes cleanly through the bulb causing it to illuminate, and the current exits the bulb through the ground source back to the battery. The ground allows everything to work properly without any issues.

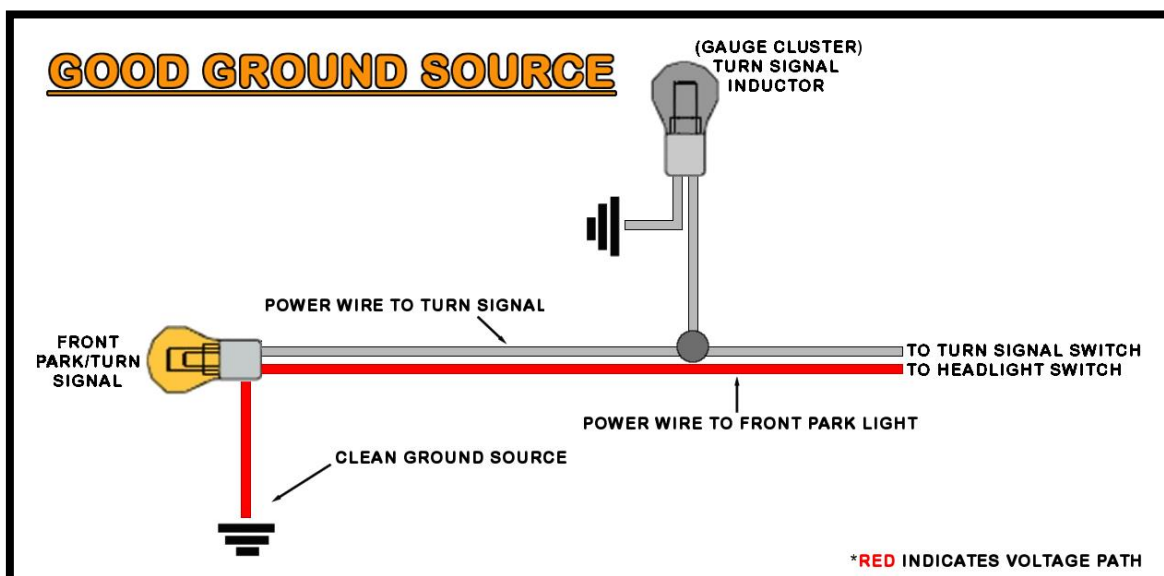

When a ground is not connected properly or is contaminated with dirt, corrosion, or paint, the current will then find the easiest path to ground. This is represented in the diagram below.

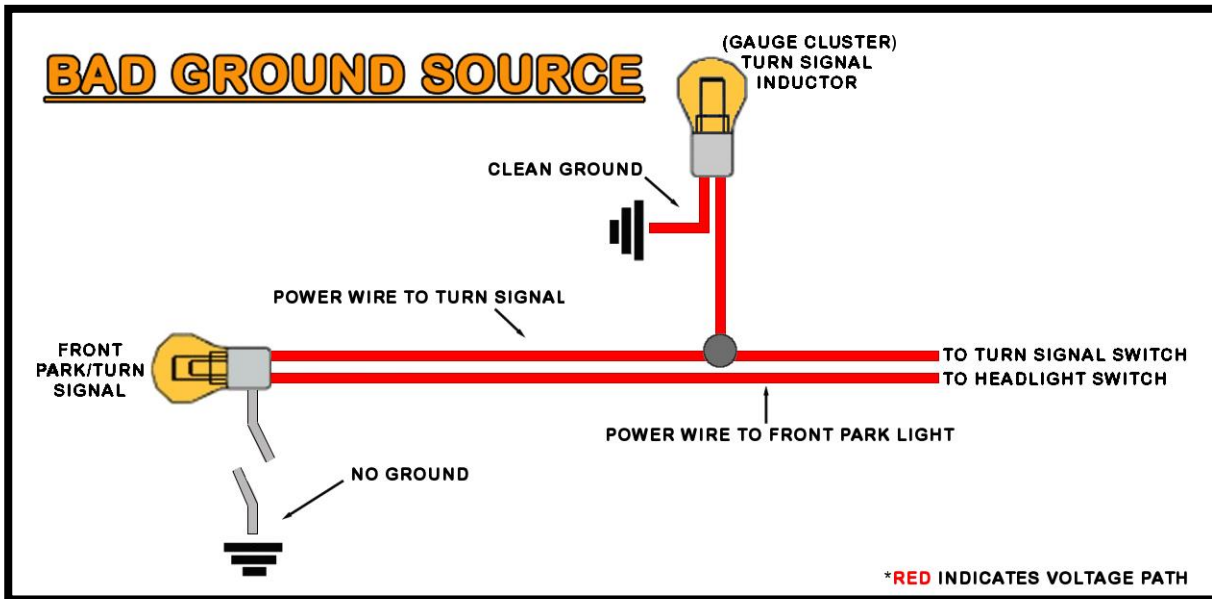

Current travels from the headlight switch to the park light bulb element but wait there is no ground at the bulb. Since the ground it normally uses is not there, the current finds another path to ground and back to the battery. When this happens, things that should not have power receive power coming from the park light bulb. Since the turn signal wire also goes to the bulb, the current will travel out of the bulb through the turn signal wire. Notice this bad ground at the front park/turn signal bulb can cause issues on the interior of the vehicle at the turn signal indicator on the dash. In this case, the turn signal indicator light is illuminated when it should not be. Also, since this one power source which was only supposed to power 1 bulb is now powering 2 bulbs, both bulbs may be dimmer than they would be if everything were grounded properly. This is one of the problems with diagnosing a bad ground: they can cause issues throughout the entire vehicle.

FUSE BLOCK

Your Painless harness contains a pre-terminated fuse block that uses modern ATC blade style fuses. There are 18 fuses controlling 28 circuits. This fuse block allows the convenience of having both flashers (turn signal and hazard), as well as the horn relay, all mounted in one location.

HORN RELAY

On the fuse block, you will find a horn relay that replaces the factory core support/firewall mounted horn relay found on many older vehicles. The fuse block mounted horn relay uses a standard 30-amp SPST relay and is ground activated from a wire in the Turn Signal Switch group of wires. Replacement relays for the horn relay can be found at any auto parts store or by ordering [Painless part number #80131](#).

FLASHERS

The two flashers simply switch power on and off going to the turn signal switch and hazard switch. The flasher on the right is the hazard flasher. The flasher on the left is the turn flasher.

How a flasher functions is simple. Power is switched off and on according to heat built-in the resistance wire inside the flasher.

As soon as the current is drawn through the flasher, as when the turn signal or hazard switch is activated, the resistance wire heats up and contacts the output side of the flasher. This contact passes power through the flasher, into the switch, and to the turn signal lamp(s). Once this contact is made, the resistance wire is no longer resisting any current, so it begins to cool; this cooling causes the flasher to lose contact. This loss of contact means that there is no longer any current going to the switch, causing the turn signal light to turn off. Once contact is lost, the resistance wire begins heating up and the entire process starts over again until the turn signal switch or hazard switch is disengaged

Some LED turn signals do not draw enough current to activate a typical thermal flasher. If you are using LED turn signals, and your turn signals do not work properly and you are certain everything is connected properly, a no-load flasher will be required ([Painless part number #80230](#)).

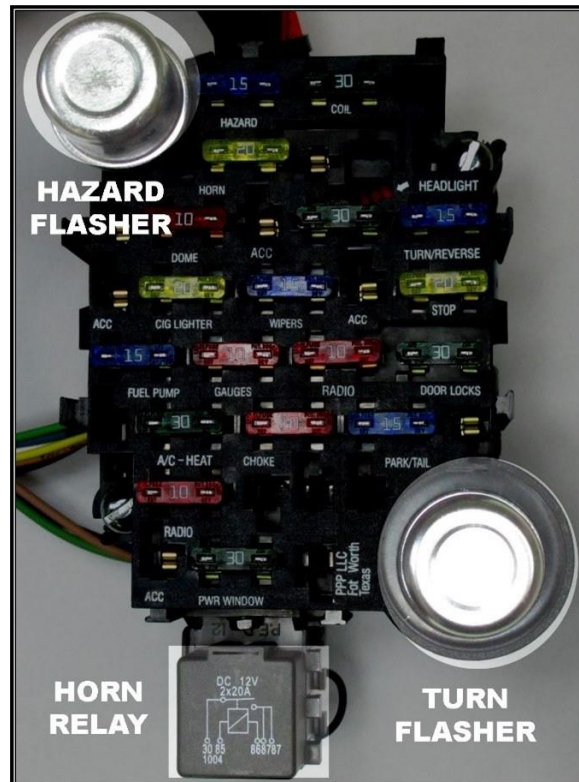

FUSE IDENTIFICATION

The following two diagrams and information will detail each fuse and which components/circuits each fuse powers.

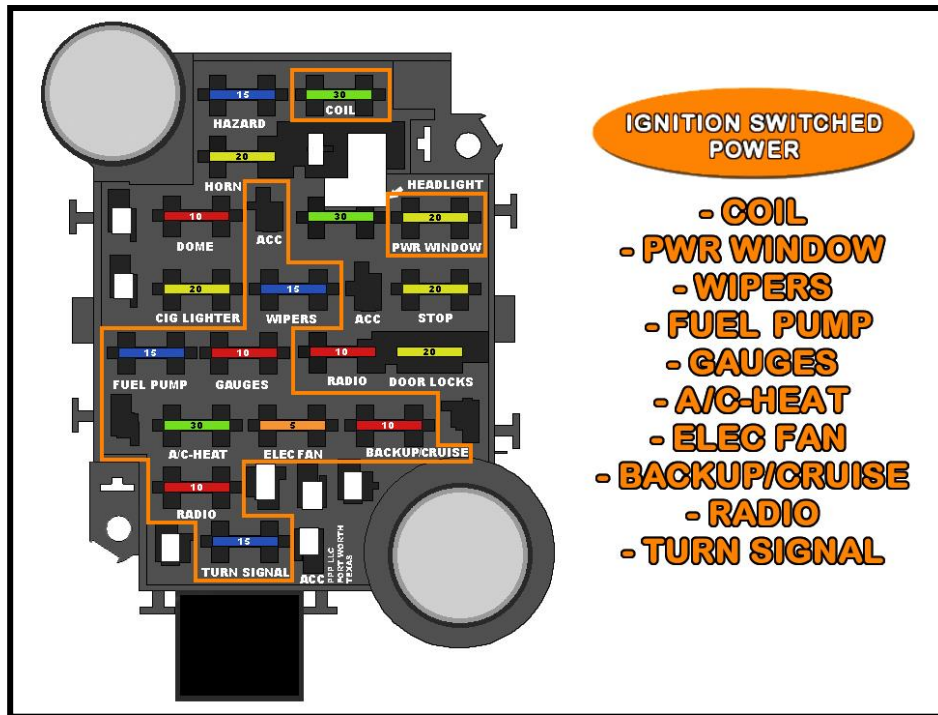

The drawing above shows all the switched ignition fuses. These fuses are powered by wires coming from the ignition switch (wires #931, #932, and #933) and receive power depending on what position the ignition switch is in. **NONE OF THESE FUSES SHOULD HAVE POWER WHEN THE IGNITION IS IN THE OFF POSITION.** The **Ignition Switch Section** beginning on [page 92](#) of this manual will go into further detail about the power supplied to these fuses.

The drawing below shows all the battery power fuses. These fuses are powered by a wire that comes from the large power splice, seen on [page 48](#). The battery power fuses always have power.

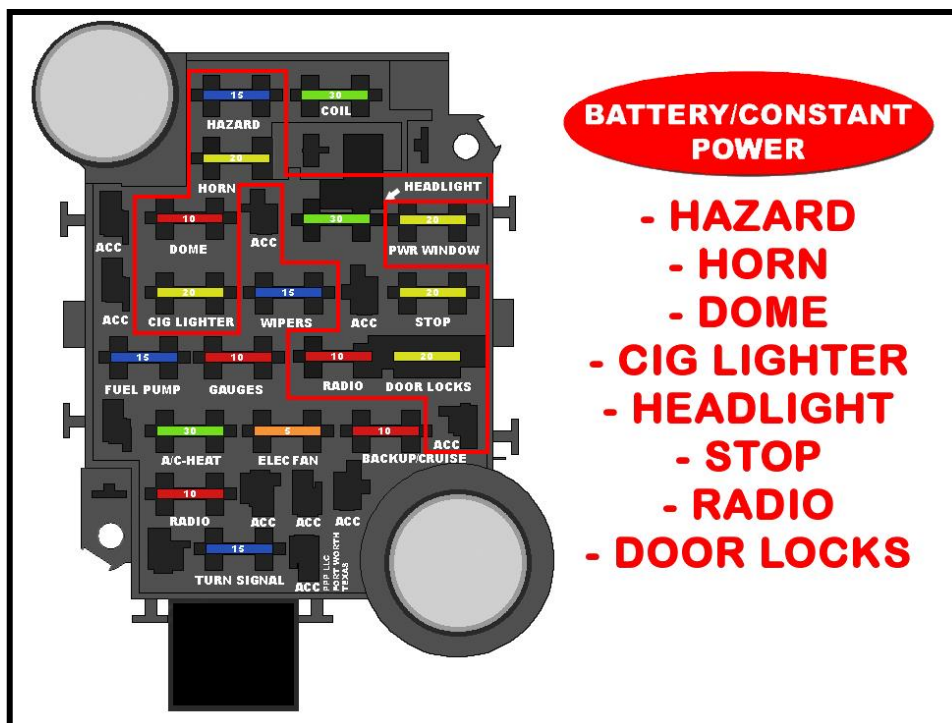

RELAYS & SWITCHES

All ACCESSORY wires found in this harness can support up to 15-amps alone. Components requiring more amperage will need to be connected to a relay. The amount of amperage needed by the component will determine the size of the relay and circuit breaker needed. An ACCESSORY wire can be used as a 12-volt activation source or a 12-volt source for ground activation in these circumstances.

A 12-volt activated relay is constantly grounded. As the name implies, the relay sends power from the output side of the relay to the component being powered when 12 volts is applied. The 12-volt source can be wired directly to the relay or interrupted by a switch, as shown in the *12 VOLT SOURCE ACTIVATION* drawing.

Wiring directly to the relay, as indicated by the dashed line, would be used in the case of wiring a water pump relay or any other high amperage component you would want to run continuously while the key is in the on position. In these cases, make certain the 12-volt wire you are using is an Ignition Switched 12-volt wire and not a battery constant hot.

The 12-volt activation wire can also be wired to a switch to offer the user OFF/ON capabilities. In these situations, a constant battery power source would be used. This would allow a component to be turned OFF or ON without the key in the ON position.

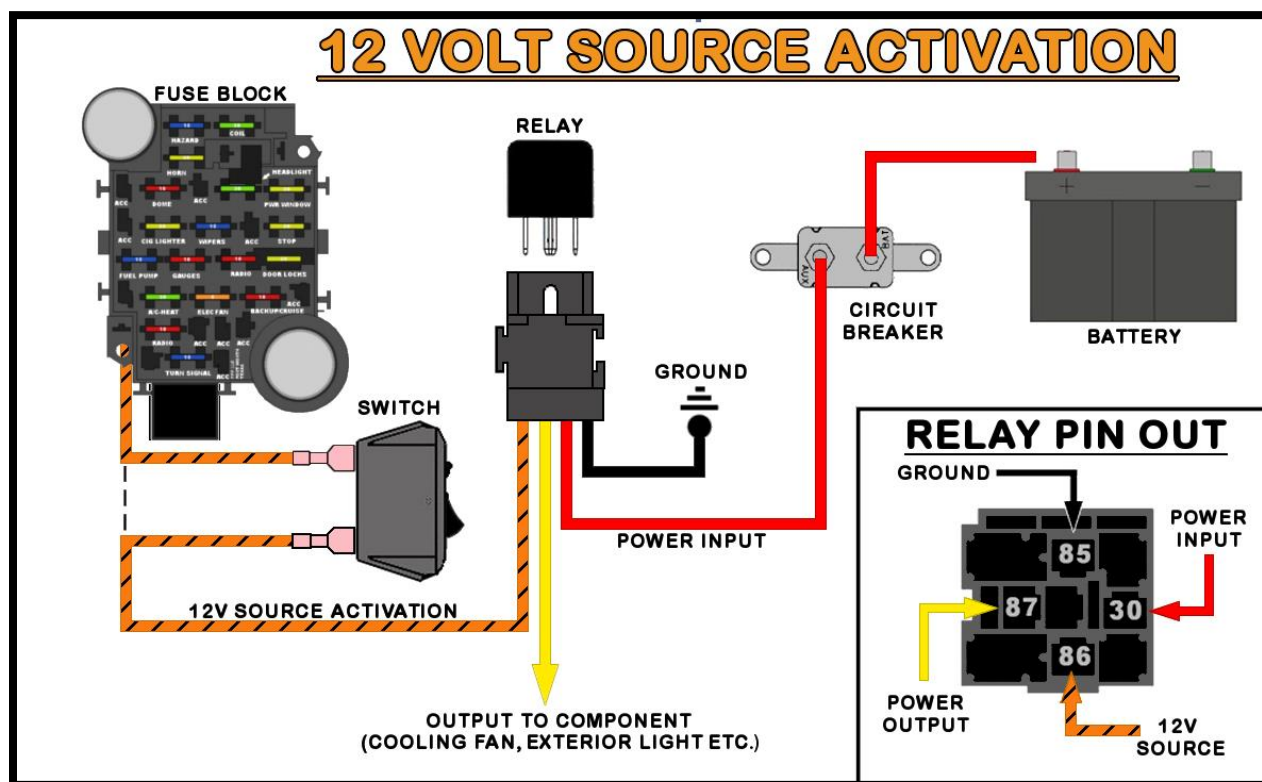

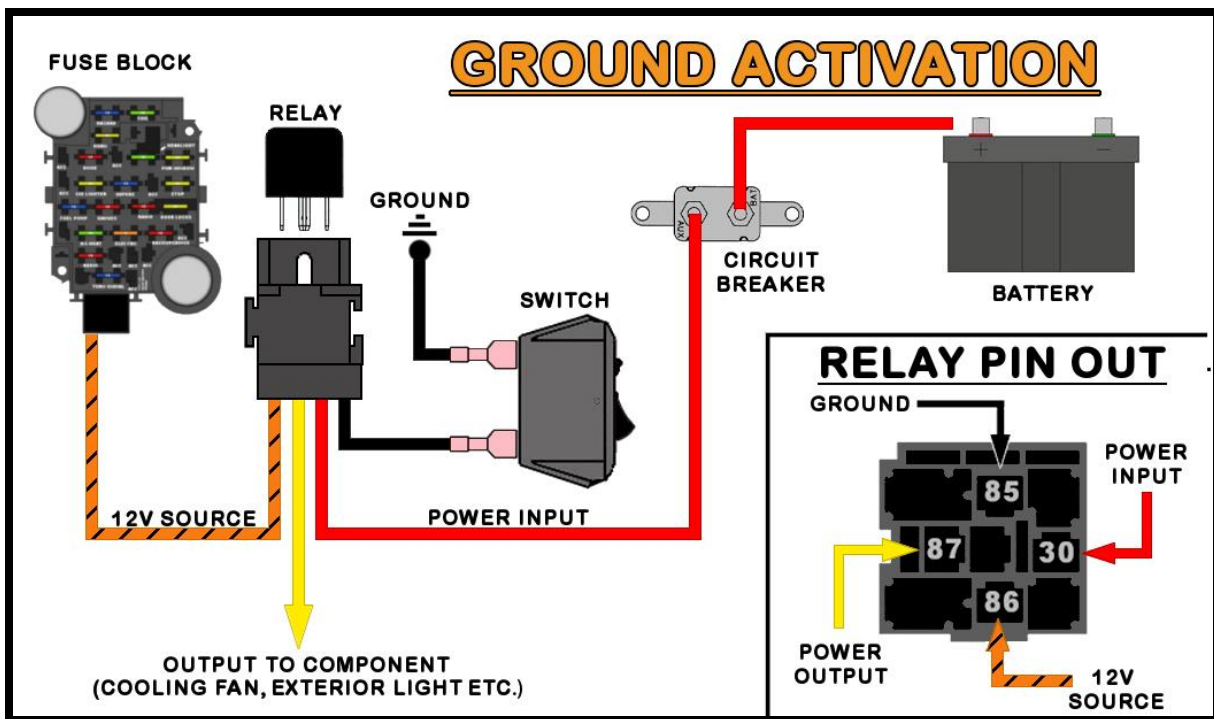

A ground activated relay is just the opposite of the 12-volt, activated relay; 12 volts (battery constant or switched) is supplied uninterrupted and the ground wire is switched. The Horn Relay pre-wired in the Painless harness is a Ground Activated Relay. Another example of this method is a thermostat operated fan relay. In this case, however, a thermostatic switch would replace the switch in the drawing above (see below).

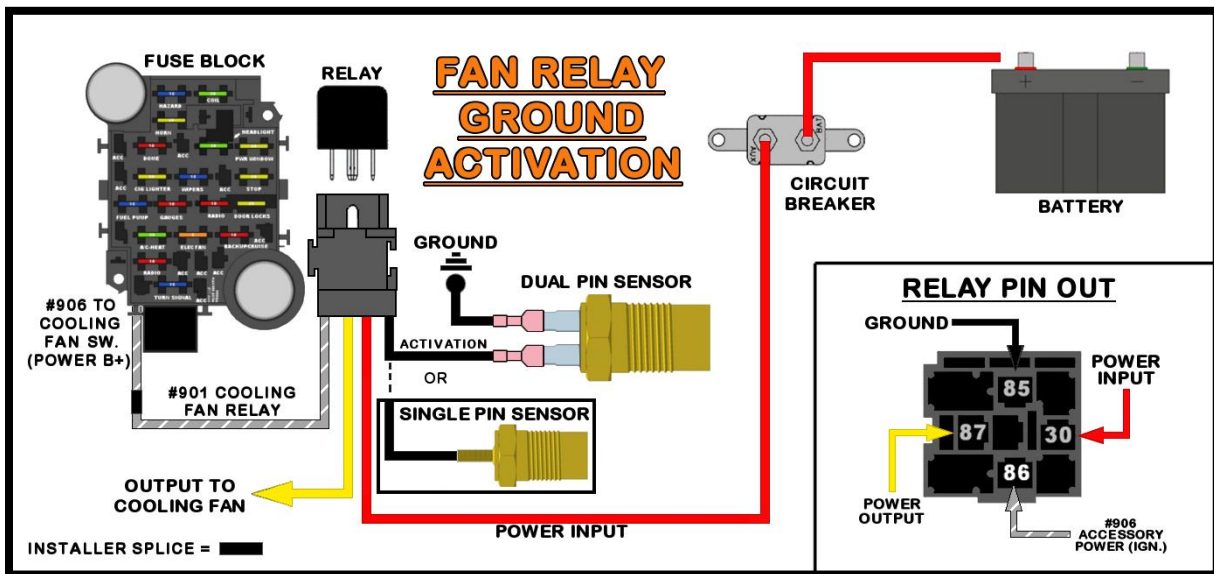

IF A TOGGLE/ROCKER SWITCH IS BEING USED WITHOUT A RELAY, MAKE SURE THE AMPERAGE OF THE COMPONENT YOU ARE POWERING DOES NOT EXCEED THE CAPABILITIES OF THE SWITCH OR SWITCH FAILURE WILL OCCUR. IF YOU NEED A RELAY KIT [PAINLESS OFFERS PART #'S 30128, 30128, & 30130.](#)

OLD FACTORY HARNESS REMOVAL

During the removal of the old, factory harness, avoid making any unnecessary cuts to any wires. The entire harness should be able to come out of the vehicle without any cutting at all unless someone has modified connections.

Labeling the factory harness is highly suggested as it may be helpful to look back at the factory harness during the install of the new Painless harness. Plus, taking this step helps you identify anything that may not be included in the Painless harness and will need to be re-used. Individual wires and connectors can easily be labeled using masking tape.

Take photos or make a drawing of any connections that have multiple connectors, like the wiper motor, wiper switch, radio, etc., to help with reconnecting the new harness.

Cars with factory heat, air conditioning, power locks/windows, and/or power antenna:

These factory accessory harnesses do not need to be removed during the removal process. They are generally separate harnesses. The power supplies for the separate harnesses simply need to be disconnected. They are usually plugged into the front of the factory fuse block or on the factory horn relay.

To aid in the removal and installation of the harness, first, remove the driver seat or bench seat and then the steering wheel. It is not completely necessary to remove the steering wheel; however, doing so allows you more room to work while removing the factory harness and installing the new Painless harness. Also, **if the Tail Harness is to be routed through the interior of the vehicle**, the sill plates and rear seat will need to be removed to route the wires under the carpet.



PRE-INSTALLATION GUIDELINES

Learning your new harness:

Before moving your harness into your vehicle, it is a good exercise to lay the entire harness out next to your vehicle. This will allow you to identify all sections of your new Painless harness. Wires are marked to help ease the process of routing.

You will note when you pull the harness out of the box that it is organized and twist-tied into **three main sections**. These sections are:



- **FRONT SECTION:**

This section is made up of three parts: The **Engine Section**, **Start/Charge Section**, and **Front Lighting Section**. The **Engine Section** consists of wires for connections such as oil pressure and coolant temperature sending units, coil or ignition system connections, and a wire for an electric choke on a carburetor.

The **Front Lighting Section** consists of wires for turn signals, parking lamps, headlights, horn power, and a 12 Volt activation wire that can be used for a fan relay.

The **Start/Charge Section** has two sections labeled **Alternator** and **MIDI**.

All wires of these sections have ample length to account for the numerous ways components can be mounted inside of an engine compartment. This will allow you to route your wires cleanly and terminate at the length you find fits your build best.

- **INTERIOR SECTION:**

The Interior Section consists of wiring for the interior/cab of the vehicle. This includes wiring for your headlight switch, turn signal switch, radio power, instrument panel. If using kit **#10201** or **#10203**, your harness ignition switch wiring will be pre-terminated with the proper connector for a GM key on the column style ignition switch.

- **TAIL SECTION:**

The Tail Section consists of wiring for taillights, brake lights, rear turn signals, dome lights, trunk accessory light, fuel sending unit, third brake light, and backup lights.

When bundling wires into groups, use zip-ties, split loom, or tape. The exposed wires in the engine compartment and wires running to the rear of the vehicle are best protected by wire loom or covering. Painless offers the **Power Braid Kit part #70920** and the **Classic Braid #70970** to fill this need. These kits include everything you will need to properly protect your new chassis harness.



DO NOT SKIP THESE PRE-INSTALLATION STEPS

- **Tail Section:** The **Tail Section** will route through the interior in MOST cars. If your factory tail harness runs through the interior and back towards the rear of the vehicle, the **Tail Section** can remain in its current location in the harness, however, some installers also find it easier to route this section to exit the bottom or the left side of the fuse block to make it easier to route under a door sill plate.

In trucks and some cars, you will run the tail section wiring through the firewall grommet and underneath the vehicle along the frame rail. If this is the case with your install, move the **Tail Section** to the breakout of the harness that has the **Engine Section**. Always ensure wires are not exposed or routed too close to high heat locations, such as the exhaust.

- **Dimmer Switch:** Locate the three wires that make up the **Dimmer Switch Section**. These wires are 14-gauge and colored **LT. GREEN**, **TAN**, and **BLUE/YELLOW**. If you have a later model GM steering column with the dimmer switch on the bottom of the column, these wires can be left alone. If you have a floor-mounted dimmer switch, it may be helpful to re-route these wires no to exit the bottom of the fuse block if the fuse block is being mounted above the switch on the firewall.

- **Turn Signal Switch:** If you are using an external/clamp-on style turn signal switch with an indicator light, you will usually require a 3-pin flasher. This will allow the onboard indicator lights of the switch to function properly. To integrate a new, 3-pin flasher into the system you must bypass the 2-pin flasher of the Painless harness. The flashers do not come pre-installed on the fuse block but rather are found in your parts kit. Therefore, do not install the turn signal flasher. Then, on the wire side of the fuse block unpin the **PURPLE** wires leading to the flasher and splice them together.

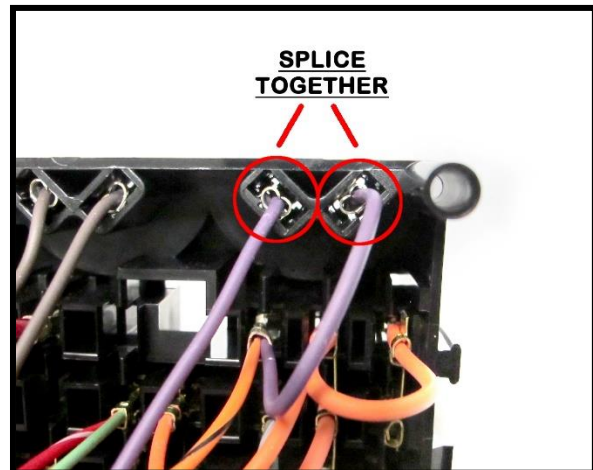

- **Headlight Switch/Dome Activation:** Locate the **BLACK #961** wire in the **Headlight Switch Section**. This is the dome light activation/ground wire. If you plan on using your headlight switch to activate the dome light, then the wire can stay in its current location. If, however, you wish to incorporate jamb switches, route this wire to the jamb switch ground circuit (note: this harness does not provide wiring for jamb switches or courtesy lights).
- **Wiper Motor/Switch:** Locate the **BLUE #905** wire in the bundle of wires printed with **ACC. Section B+**. This **#905** wire is the power for a wiper switch/motor. You will need to reroute this wire with **Engine Section** if you are using a GM firewall mounted wiper motor, or if your motor requires a switched 12v source and is activated by ground from the wiper switch. If your wiper motor is power activated from the switch, this **#905** wire can stay in its current location. Also please note, this harness does not include any additional wires for vehicles with wipers due to the numerous different systems: factory and aftermarket.

- **Brake Switch:** Locate the **WHITE #918** & **ORANGE #917** wires in **Engine Section**. If you have a hydraulic brake switch installed at the master cylinder or on a brake line, the brake switch wires can stay in their current location. If you have a pedal mounted switch, the brake switch wires will need to be re-routed to the Turn Signal Section since the brake switch is close to the turn signal switch connection.
- **Reverse Switch:** Locate the two **LT. GREEN** wires, **#956** & **#958**, intended for reverse/back up lights. If you have a GM, column-mounted reverse switch, a reverse switch on a floor-mounted shifter, or a transmission-mounted reverse switch that you plan to access through the transmission tunnel or floorboard, these wires can stay in their current location. If you have a transmission mounted reverse switch and need to access the connection in the engine compartment, re-route the **#956** & **#958** to the **Engine Section**.
- **Neutral Safety Switch (NSS):** This connection varies greatly depending on the harness and the location of the NSS.
 - **10201** & **10203:** There are 2 separate **PURPLE #919** wires for this connection: one from the starter solenoid and another from the ignition switch. If you have a transmission mounted NSS that you are accessing through the engine compartment, connect these two **PURPLE** wires on the interior.
 - **10202** & **10204:** This is a single wire (**PURPLE #919**) from the ignition switch that will be routed to the NSS and cut to length. The cut-off portion will then be used to connect the NSS to the starter solenoid.

If you have a transmission mounted NSS and need to access your connection in the engine compartment, the **PURPLE #919** wire can stay in its current location.

If you have a GM, column-mounted NSS, a manual transmission with a clutch pedal switch, an NSS on a floor-mounted shifter, or a transmission-mounted NSS that you plan to access through the transmission tunnel or floorboard, re-route the **PURPLE #919** wire from the **Engine Section** to the interior (typically with the **Reverse Switch Section**). Be aware, once you have routed the wire to the NSS and cut it to length, the cut-off portion will need to be routed out into the engine compartment and to the starter solenoid.

- **External Voltage Regulator:** If you are using a charging system that requires an external voltage regulator take notice of its mounting location. If you find that the regulator is mounted on the core support, you may want to re-route the **WHITE #914** from the **Alternator Section** to **Front Light Section**. However, if you also have a charge indicator/alternator light follow the re-routing instructions below.
- **Power Antenna:** The **PURPLE/BLACK #942** wire provides power to a power antenna and/or amplifier from the radio. This wire runs from the **Radio Section** to the **Tail Section**. However, if your power antenna is in the front of the vehicle it can be rerouted with the **Engine Section**. Also, this wire can be removed entirely if you are not using a power antenna or amp.

- **Charge Indicator/Alternator Light:** If your gauge cluster has a charge indicator/alternator light, re-route the **WHITE #914** from the **Alternator Section** to the **Instrument Panel Section**. Be aware that this wire will then be connected to one side of the indicator light, and the cut-off portion will connect to the other side of the light and then be routed out to the voltage regulator or alternator. More information on this connection can be found on [page 51](#).
- **Temp Light:** Locate the **Instrument Panel Section**. Vehicles with a factory engine temperature indicator light, instead of an actual gauge, may notice a tab on the ignition switch labeled “GND” or ground. This will send a ground source to the light when the ignition switch is in the “START” position. This will illuminate the light, letting the operator know the light is functioning. When the key is returned to the “ON/RUN” position, the switch no longer provides a ground and the light goes out. To connect this Indicator light so it functions in this manner, either run the **LT. GREEN #921** from the temp sender to the ignition switch and from the ignition switch to the light or from the temp sender to the light and from the light to the ignition switch.
- **GREY/WHITE #901** in **Front Light Section** will provide an accessory relay, like a cooling fan relay, a switched ignition 12v activation source. THIS IS NOT A POWER SOURCE FOR THE RELAY, ONLY AN ACTIVATION SOURCE. If a relay is to be mounted on the core support, make certain to route this wire to that location.
- Read through this manual with the harness laid out in front of you. Entire sections may need to be re-routed or separated due to the way or where the fuse block is to be mounted and how you want to route wires. Also, take note of wires you may not need and remove them from the harness. This will clean up the appearance of the install. **Painless does not recommend removing any power wires from the fuse block as they can be used to power other things.**
- If you are running mechanical gauges, or if you are using an aftermarket gauge cluster or individual gauges that require their own 2- or 3-wire sensors, you can remove the sending unit wires running from the **Engine Section** to the **Instrument Panel Section**.
- **Choke: RED #954** found in **Engine Section** can also be pulled back to the fuse block if you have a mechanical choke or if you are running fuel injection. As previously stated, **Painless does not recommend removing any power wires from the fuse block as they can be used to power other things.**

FIREWALL PASS-THRU

ENGINE/HEADLIGHT WIRING:

Decide how the **Front Light Section**, **Engine Section**, **Start/Charge Section**, **RED #916**, and possibly the **Tail Section** bundle of wires will be routed into the engine compartment.

- If the **Start/Charge Section**, **Engine Section**, and **RED #916** are going to be routed across the firewall in the engine compartment to the center of the vehicle and then to the engine, these sections can be routed through the same hole as **Front Light Section**, see the single-hole instructions below. If you would like to have these wires routed on the inside of the vehicle and come out of the firewall in their own grommet behind the engine, so these wires are not visible across the firewall, see the two-hole instructions.
- If you have existing holes in your firewall, these wires can pass through them. Any hole with wires passing through them absolutely **MUST** have a grommet installed.

SINGLE HOLE:

- If you have a pre-existing hole, you will need to source a grommet that will not only fit the hole but also the wires running through it. The wires of this Painless harness will require a **1" bore/opening** in the grommet. If you need to enlarge a pre-existing hole, you can make use of the grommet provided with this kit and enlarge your pre-existing hole to **1¼"**.
- If you have a bulkhead opening, a U-shaped bracket has been provided to help close this opening while also providing a pass-through, see **page 23** for more information
- If you do not have a hole, one will need to be created. Using a hole saw, drill a **1¼" hole**. This will accommodate the grommet provided in this kit. Once a hole has been drilled, install the provided grommet. Wires will be passed through this grommet after the fuse block has been mounted.

TWO HOLES: Additional grommets will be required to follow this method

- **Front Light Section** will require a separate hole. Of the following 3 steps, choose the one that best fits your install.
 1. If you **DO** have a pre-existing hole near the inner fender, you will need to source a grommet that will not only fit the hole but also the wires running through it. The wires of this Painless harness will require a **¾" bore/opening** in the grommet.
 2. If you have a bulkhead opening, a U-shaped bracket has been provided to help close this opening while also providing a pass-through, see **page 23** for more information. This bracket will require a **1¼" grommet** with a **¾" bore/opening**.

3. Drill a hole in the firewall near the inner fender for **Front Light Section** to pass through. The size of the hole will depend on the size of the grommet you use; these wires will require a grommet with at least a $\frac{3}{8}$ " **center bore/opening**. Keep in mind any additional wires, hoses, or tubing that may also need to use this hole.
- Near the center of the firewall, behind the engine, drill a hole for **Engine Section**, **Alternator Section**, and **RED #916** to pass through. For a cleaner install, drill this hole high enough that it cannot be seen while sitting in the vehicle but low enough that it is behind the engine. Again, the size of the hole will depend on the size of the grommet you use; these wires will require a grommet with at least a $\frac{5}{8}$ " **center bore/opening**. Keep in mind any additional wires, hoses, or tubing that may also need to use this hole.

FUSE BLOCK MOUNTING

To begin mounting the fuse block, find a suitable location with easy access if a fuse needs to be replaced. Most of the time, the vehicle's original fuse block location is ideal. This harness is designed with the intent of the fuse block being mounted on the driver's side of the vehicle and under the dash. **This fuse block must be mounted inside the vehicle** as it is not suitable for wet conditions.

- After the fuse block is mounted, install the two supplied flashers from the parts kit.

FIREWALL MOUNTING WITHOUT A FACTORY BULKHEAD CONNECTOR:

- You will first want to locate and mark your two fuse block mounting holes. To do this, use the metal templet/bracket provided to mark the hole location.
- Once marked, and you are sure you have chosen the most suitable location for your fuse block, use a $\frac{1}{4}$ " drill bit to create holes for the two provided bolts to mount the fuse block.
- Remove the supplied bolts on the fuse block and install the bolts through the firewall and the fuse block. Install the flat washers and nuts previously removed from the fuse block; this requires the use of a $\frac{7}{16}$ " socket or wrench. A helper with a flat head screwdriver is needed to keep the bolts from turning while the mounting nuts are tightened.

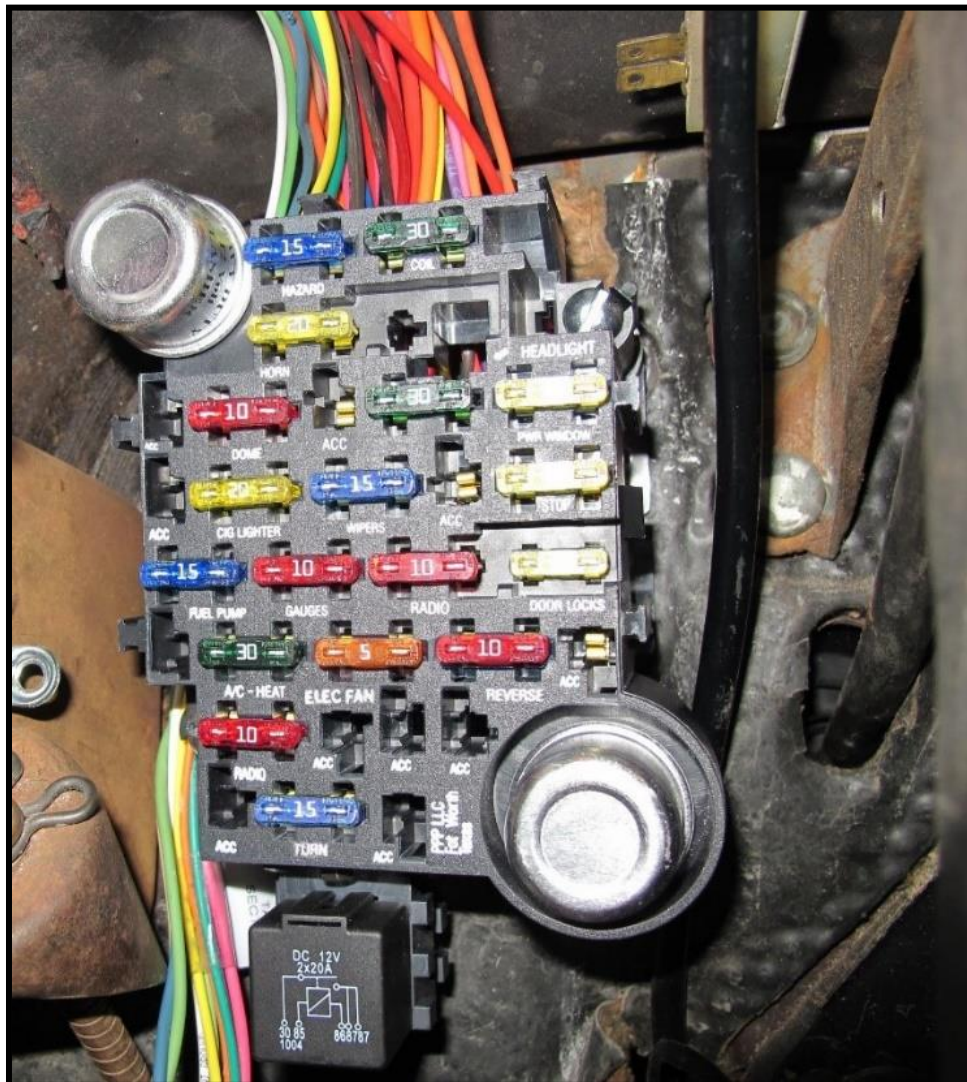

BRACKET MOUNTING THE FUSE BLOCK:

- Additional nuts, bolts, and/or self-tapping screws may be needed to perform the following mounting procedure.
- Find a suitable spot for the fuse block mounting bracket. Existing bolts holding the brake booster or master cylinder, steering column, or other things already mounted to the firewall can make for good mounting solutions. The area above the kick panel may also be a practical spot for your fuse block.
- Modifications to the bracket may be needed to allow proper mounting. Also, creating studs out of the fuse block mounting bolts by installing the bolts and nuts to the bracket before installing the fuse block, may make it easier to mount the fuse block and mounting bracket. **(2) ¼" - 20 nuts** will need to be sourced to mount the fuse block this way.

If mounting the bracket to the area above the kick panel, or any other surface, you may be able to simply run a couple of screws through the small mounting holes in the bracket. **(2) Self-tapping screws** have been provided in the parts kit to accomplish this.

- The fuse block may need to be mounted to the bracket before the bracket is mounted to the vehicle. At this time, mount the bracket and the fuse block.



HARNES ROUTING

Loosely route all the wire groups to their designated connection points. **NO CONNECTIONS OR CUTTING WILL TAKE PLACE AT THIS TIME.** Harness routing is and should be a time-consuming task. Taking your time will enhance the appearance and quality of the installation. Please be patient and **TAKE YOUR TIME. REMEMBER TO ROUTE THE HARNESS AWAY FROM SHARP EDGES, EXHAUST PIPES, HOOD, TRUNK AND DOOR HINGES, ETC.**

WHILE ROUTING WIRES: If you are to go through an inner fender well, core support, or any other metal pass-through YOU MUST INSTALL A RUBBER GROMMET.

- Route the **Front Light Section** down the inner driver side fender to the core support. In some cases, you can route this section inside the fender and over the wheel well to help hide the wires to keep the install clean. Loom will need to be added to the harness prior to routing the harness over the wheel well.

GREY/WHITE #901 in **Front Light Section** will provide an accessory relay, like a cooling fan relay, a switched ignition 12v activation source. If a relay is to be mounted on the core support, make certain to route this wire to that location. **This wire is not intended to power a cooling fan, but only to provide 12v activation for a cooling fan relay.**

- Once at the core support, isolate the wires for the left-hand side and right-hand side lights. The **BROWN #927**, **LT. GREEN #908**, and **TAN #909** will have different lengths, 3 long and 3 short, with the short wires running to the first group of lights you come to. Take notice at this time to the horn wire, and where the horn(s) are located. Route the wires for the other side lights across the core support to the other side of the vehicle. On most vehicles, the radiator hold-down will usually need to be removed to allow access to the channel that runs along the top of most core supports where factory wiring was once run. This routing of the front light section makes good use of the supplied zip ties.
- Route **Engine Section**, **Alternator Section**, and **RED #916** towards the center of the firewall. Routing of the individual wires will be easier to accomplish during the time of their specific connections.

If the two-hole method from **pages 20 – 21** was used, these wires will route with the interior harness to the center of the firewall. They will need to be passed from the interior of the vehicle out into the engine compartment.

ON THE INSIDE OF THE VEHICLE:

- Route the wires intended for dash-mounted components/switches towards their connection points on the dash at this time. Pay attention to the **Accessory Sections** as both bundles contain wires that can/will be routed to different places.
- Route the **Tail Section** group of wires either through the interior of the vehicle to the rear or through the firewall and underneath the vehicle. If you route the **Tail Section** down the frame under the vehicle, it is especially important to cover the wire with some sort of wiring loom
- At the back of the vehicle, route the wires to the left and right connections as indicated by the print found on the wires.
- Once all the wires are routed and running to the general location of their components, you can begin making connections. We prefer to start with the **Front Light Section** and work from the front of the vehicle to the back.

FRONT LIGHT SECTION

The **Front Light Section** of this Painless Harness includes all the power wires needed to properly hook up both driver and passenger side headlights, front turn signal lights, and park/marker lights. There is also a power wire from the fuse block mounted horn relay to power the horn(s). All wires in the **Front Light Section** can be seen in the [Front Light Section Schematic](#) on [page 36](#).

Ground wires will need to be provided for both front turn signals. Ground for the headlights can be sourced through the wire on the provided pigtails.

If halogen bulbs are being used, a separate headlight relay kit MUST be used.

Due to the higher amperage demands of halogen lights, these lights will cause the circuit breaker in the headlight switch to fail. A headlight relay harness provides battery power through the relays directly to the headlight bulbs. The headlight switch will activate the relays, thus drawing only 1 amp of current. This is beneficial for both the longevity of the headlight switch and the brightness of headlight bulbs themselves. Painless offers part [#30814](#) for dual/quad headlights and [#30815](#) for single headlight vehicles.



LEFT / DRIVER SIDE HEADLIGHT

Your first connection in **Headlight Section** will be the Left/Driver Side Headlight. Two wires are provided for connection to the Left Headlight, they are:

LT. GREEN: 16-gauge wire, printed **[FRONT LIGHT SECTION] #908 HEADLIGHT HIGH BEAM**; this wire provides power to the high beam filament of the headlamp. This wire runs from the dimmer switch and has power when the dimmer switch is in the high beam position and the headlight switch is in the headlight ON position.

TAN: 16-gauge wire, printed **[FRONT LIGHT SECTION] #909 HEADLIGHT LOW BEAM**; this wire provides power to the low beam filament of the headlamp. This wire runs from the dimmer switch and has power when the dimmer switch is in the low beam position and the headlight switch is in the headlight ON position.

The connection of these wires will depend on the style of headlights you are using in your application.

3 prong, Sealed Beam/Sealed Beam Halogen/H4 Halogen



Pre-terminated connectors (shown in the image below) have been provided in the parts kit to allow proper connection to these style headlights.

- Most factory headlights were grounded to the core support. If your vehicle has this grounding location, cut the pre-installed splice off the **BLACK** wire of the pigtail
- Strip $\frac{1}{4}$ " of insulation from the wire and install a **BLUE $\frac{3}{8}$ " insulated ring terminal** from the parts kit. This will keep you from having to run a separate ground wire to the headlamp(s). If you cannot, or do not, want to ground the headlamp(s) in this way, a ground wire must be provided by you, the installer.
- Route the **#908 & #909** wires for left/driver side headlamp connection to the back of the headlamp. Removing the headlamp may be necessary.
- Taking the length of the pigtail wires into consideration, cut the **#908 & #909** wires to length and strip $\frac{1}{4}$ " of insulation from them.

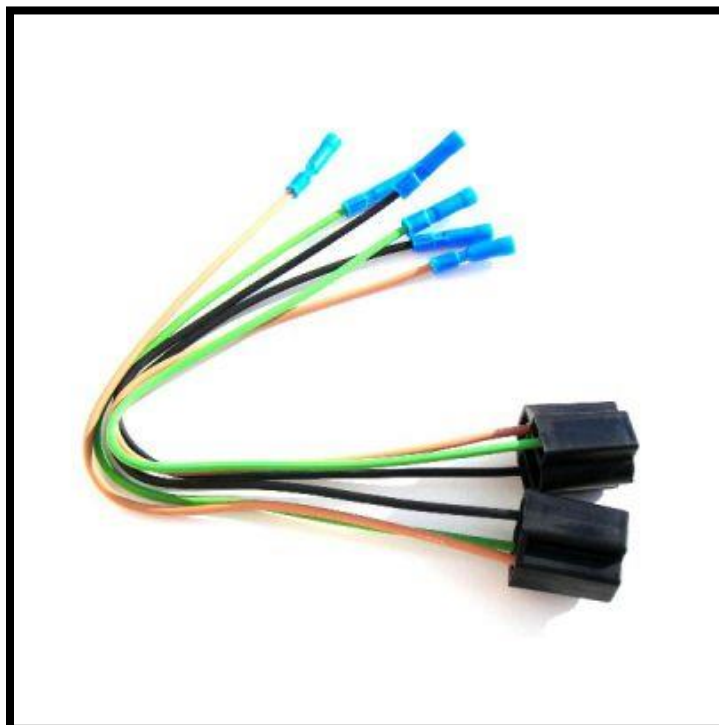

If your vehicle is equipped with dual/quad headlights, meaning the vehicle has a high/low beam light and a separate high beam light on each side, as shown below, additional pigtails will need to be purchased ([Painless #80300](#)). The **LT. GREEN** wire from one of these pigtails will also splice to the **LT. GREEN #908** wire. See the diagram on [page 36](#) for a visual reference.



- Using a set of standard crimpers, as shown on [page 5](#), and matching wire colors, crimp the **#908 & #909** wires onto the 3-prong headlight pigtail. At this time, splice the ground wire too if you are not grounding with a ring terminal.
- Plug the connector onto the prongs of the headlamp. Make sure the connector is inserted straight onto the prongs as these prongs will easily bend making a proper connection difficult. Dielectric grease is provided to help keep this connection corrosion-free. Adding grease to the terminals of the connector before plugging them onto the headlamp will ensure your lights stay bright and will help with the removal of the connector the next time the headlamp needs to be disconnected.

Headlights with Pigtails

To make the appropriate connections consult the manufactures instructions of the headlights you are using to identify the function of each wire. If you do not have instructions or know the manufacturer of the lights on your vehicle, you can test a light using your vehicle's battery.

On units that have 3 wires, in almost all cases there will be a black wire, this is typically a ground, while the other two-colored wires are the power for the high and low beams. Units with 5 or 6 wires also have turn/park light features.

- Touch one of the colored wires to the positive side of the battery.
- With the colored wire touching the positive side, touch the **BLACK** wire, or both **BLACK** wires if your lamp also has a turn/park, to the negative side. You may see a couple of tiny sparks upon connecting to the negative side, but this is normal. The light should now be on, take notice of how bright the light is.
- Remove both wires from the battery and repeat this process with the other colored wire(s). First to the positive side, and then the ground(s) to the negative side.
- Whichever wire on the positive side of the battery made the light(s) brighter is the high beam power wire or turn signal if your lamps have this option. Write this down in the notes section at the back of this manual for future reference.



In some cases, headlamps will have a **GREEN**, **BROWN** or **TAN**, and **BLACK** wire coming from them, as shown in the photo above. This is a common GM style color code meaning: **BLACK** = ground, **BROWN** or **TAN** = low beam, **GREEN** = high beam.

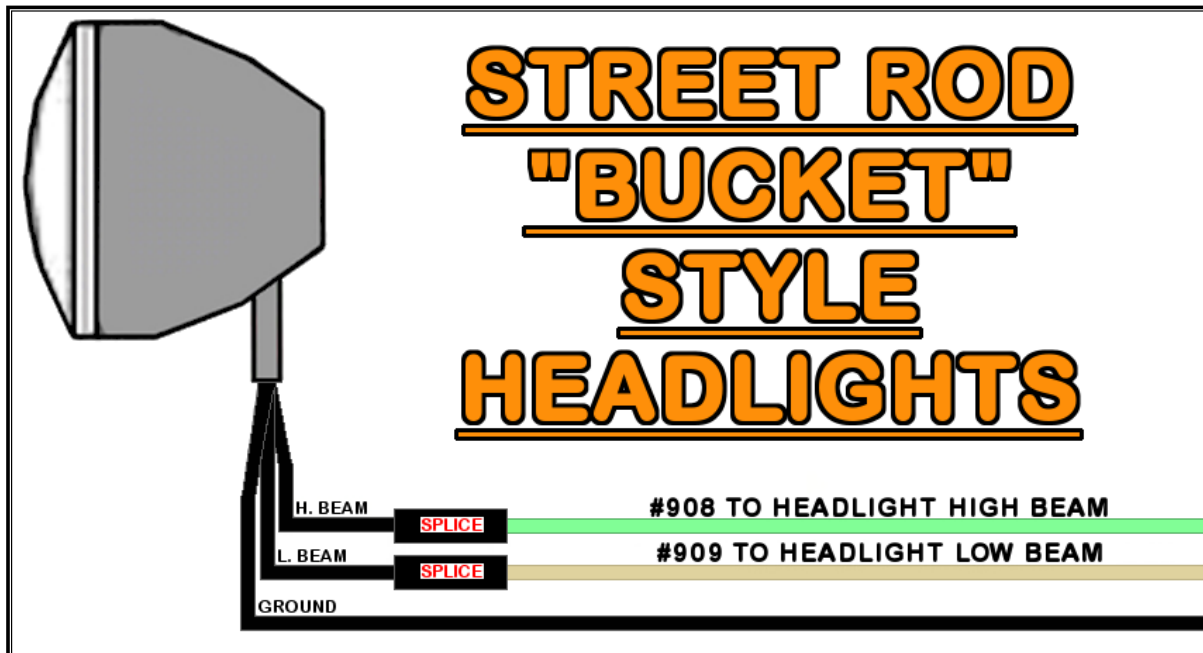

- Connection of the **#908** & **#909** wires of the Painless harness will be made using the splices provided in the parts kit.
- Each wire, coming from the headlight bucket as well as the Painless Harness will need to be cut to length and have $\frac{1}{4}$ " of insulation stripped from them.
- Connect the splice to each of the 3 wires on the Painless harness.
- Insert the wires from the headlight bucket into the splice that corresponds with the wires function:

High Beam wire to the Painless **LT. GREEN** wire printed **#908**

Low Beam wire to the Painless **TAN** wire printed **#909**

Ground wire to the installer created ground

LEFT PARK / SIDE MARKER LIGHT

The driver side, fender-mounted marker light is the next connection. Some vehicles may not have this light. If this is the case with your install, skip to the next section, LEFT TURN / PARK LIGHT on [page 33](#). It can serve one or two purposes: One, it can work simply as a front marker/park light, or two, it can work as a park light as well as a turn signal. Both functions are dependent on how you wire the lamp socket.



The park light feature is activated by a power source coming from the headlight switch. This light illuminates any time the headlight switch is in the “PARK” or “ON” position. The turn signal feature is provided by a power source coming from the turn signal switch.

The left side marker requires two wires to work properly; the way you want the light to function determines if both wires need to connect to the park/marker light. These wires are:

BROWN: 18-gauge wire, printed **[FRONT LIGHT SECTION] #927 FRONT PARK LIGHTS**; this is a power wire for the park and marker light function. This **#927** is spliced to the other **#927** wire in the **Front Light Section**. This wire has power anytime the headlight switch is in the Park/Taillights ON or Headlights ON position.

LT. BLUE: 18-gauge wire, printed **[FRONT LIGHT SECTION] #926 LEFT FRONT TURN SIGNAL**; this wire is the power for the turn signal function. This wire comes from the turn signal switch and has interrupted switched power from the turn flasher anytime the left turn signal is activated. It also receives interrupted battery power from the hazard flasher anytime the hazard switch is in the ON position.

- Most vehicles will need to use an installer sourced light socket like the one seen below. These can either be cut from your factory harness or purchased from most auto supply stores using part **#PT60** or **#S74**. These sockets use a wedge base **#194** bulb,

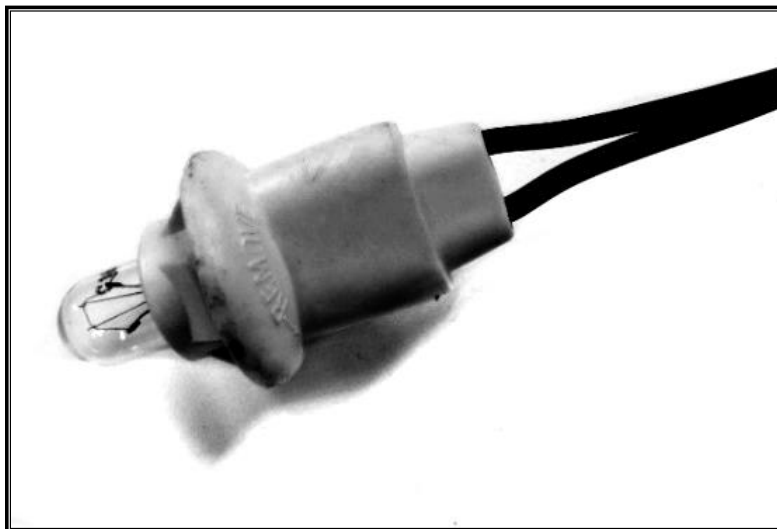

- Looking at the backside of the marker lamp housing, you will see that it has a keyed opening to correspond with the tabs on the socket (as seen in the photo). Temporarily install the socket into the marker light assembly
- Route the **BROWN #927** wire to one of the wires of the socket and cut the **#927** to length; save the cutoff piece of #927. It does not matter which wire on the socket the **#927** connects to.
- If you **do not** want the park/side marker lights to also work as turn signals, connect the other wire from the socket to a chassis ground source. If you are using a new socket, it may already have a ring terminal preinstalled.
- For the park/marker light to also work as a turn signal, route the **LT. BLUE #926** wire to the other wire of the socket and cut the **#926** to length, save the cutoff piece of #926.
- Using splices from the parts kit, connect the **#926** and **#927** wires to the lamp socket. Double up with the cut off pieces to allow connection to the front turn/park light as shown in the diagram below.

If you are connecting the **#926** turn signal wire to the park/side marker light, you will notice that there are no means for a direct ground to be applied to the light. This is because the path to ground will travel from this park/side marker socket to the front turn signal socket, through either one of the wires, and ground through the front turn/park light. The front turn/park signal socket is a higher wattage bulb. So, when the ground passes through that bulb it will not cause the front lamp to illuminate since it has a greater power requirement than the park/side marker light.

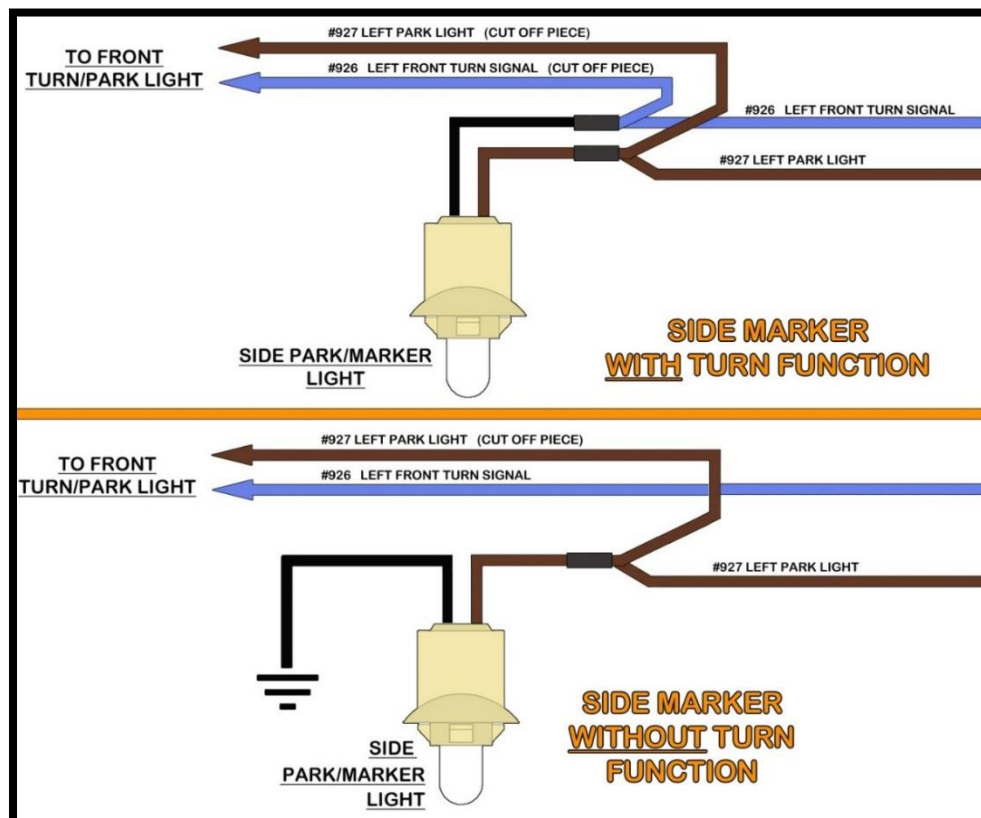

LEFT TURN / PARK LIGHT

The Left Turn/Park Light of the Painless harness consists of 2 wires. These wires are:

BROWN: 18-gauge wires, printed **[FRONT LIGHT SECTION] #927 FRONT PARK LIGHTS**; this wire provides power to the park lights. This wire splices to a single **BROWN** wire leading to the headlight switch. This wire has power anytime the headlight switch is in the Park/Taillights ON position.



LT. BLUE: 18-gauge wire, printed **[FRONT LIGHT SECTION] #926 LEFT FRONT TURN SIGNAL**, this wire is the turn signal power. This wire has interrupted switched power from the turn signal flasher any time the left turn signal is activated, and the ignition is in the ON position. It also receives interrupted battery power from the hazard flasher any time the hazard switch is in the ON position.

If your turn signal has a dual filament bulb and only 2 wires, you do not need to connect a separate ground wire. Your light socket grounds through the mounting of the lens/bucket. If your vehicle has been freshly painted, you will need to clean the paint from the mounting surface of the light housing. The use of a small star washer on the mounting screws can ensure your light housing is grounded properly.

If you find that your turn signal requires a ground wire, this connection must be sourced by you, the installer.

If your light has a single filament bulb, your lens will only act as a turn signal, because the **#927** wires will not have a connection point. Check your local laws to see if front park lights are required; you could be in violation of the law without them. If you can run without the front park lights, the **#927** wires, along with the single wire going to the headlight switch they splice to, can be removed from the Painless harness.

- In some cases, your turn signal will have wires hard wired to the light and exiting the turn signal assembly, usually into a connector of some sort. Remove this connector and use the blue insulated pin/socket terminals to connect the **#926** & **#927** wires to the turn signal.
- For those with a turn signal that requires a light socket, either cut the socket from your old harness or contact your favorite auto parts supplier for a new one. Many of these light sockets can be purchased as a pigtail. Splices have been provided to connect the **#926** & **#927** wires to the turn signal pigtails
- Route the wires needed for installation to the turn signal. Cut the wires to length and strip **1/4"** of insulation from all wires.

HORN

The **Front Light Section** has a single wire dedicated to connecting to a horn. *Most horns ground through their mounting and only require a power connection. This wire is:

GREEN: 14-gauge wire, printed **[FRONT LIGHT SECTION] #924 HORN**; this is a power wire that comes from the fuse block mounted horn relay. It is ground activated by the horn button on the steering column, and only has power when the horn button is pressed.

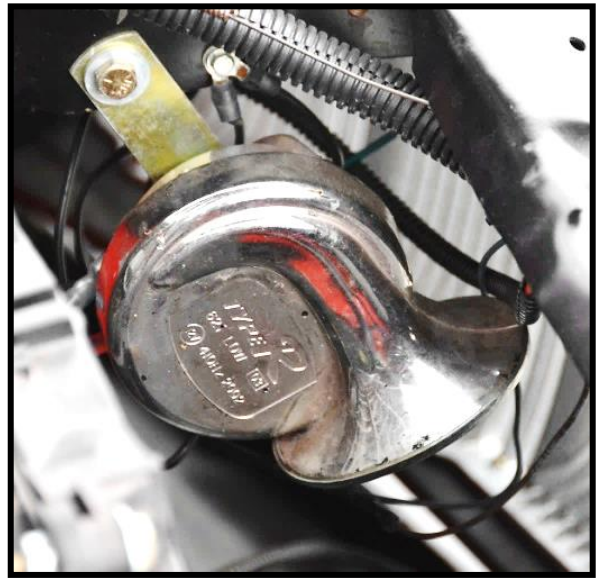

- Route the **#924** wire to the horn and cut it to length. If you pass this wire through any metal surfaces, you will find small grommets in the parts kit to protect the wire. If you have two horns, save the cutoff portion of **#924**.
- If you have a tab on the horn, insulated “spade” style terminals have been provided in the parts kit.

#10 ring terminals have been provided for those with “screw” or “post & nut” connections. If your horn has a wire to connect to, then a splice from the parts kit will work for this connection

- Strip **1/4”** of insulation from the **#924** wire and crimp the appropriate terminal onto the wire. If you have more than one horn, strip **1/4”** wire from the cutoff piece of **#924** and double the cutoff piece of **#924** to the **#924** coming from the relay. A terminal to connect this wire to the horn will need to be sourced by the installer, doubled up 14-gauge wires will require a **10-gauge terminal**.
- If your horn requires a ground wire, it will need to be provided by the installer.

ACCESSORY / FAN RELAY

While this Painless harness does not include any wiring specifically for a fan relay. There is a **GREY/WHITE #901** wire in the **Front Light Section** that can be used for a 12v activation.

GREY/WHITE: 18-gauge wire, printed << **[FRONT LIGHT SECTION] TO COOLING FAN RELAY**<< **#901** >> **TO COOLING FAN SWITCH [ACC. SECTION SWITCHES]** >>; This wire will only have power if it is connected to the **GREY/WHITE #906** wire. This wire can be used for the activation of the relay coil only and **MUST NOT** be used to directly power a cooling fan.

See **page 115** for more information on accessory connections before connecting this wire. The remaining relay wiring, circuit breaker, relay, and temperature switches seen in the diagram are **NOT** included in this kit. Painless does offer numerous relay kits that do include these parts, like **Painless #'s 30101, 30102, or 30103**.

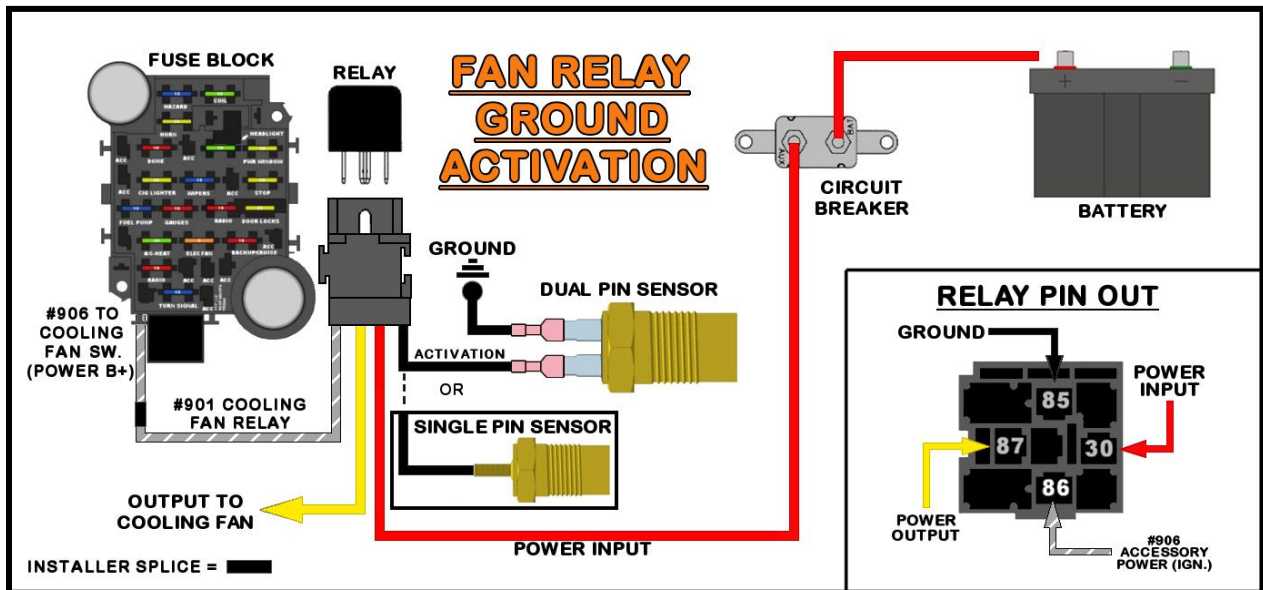
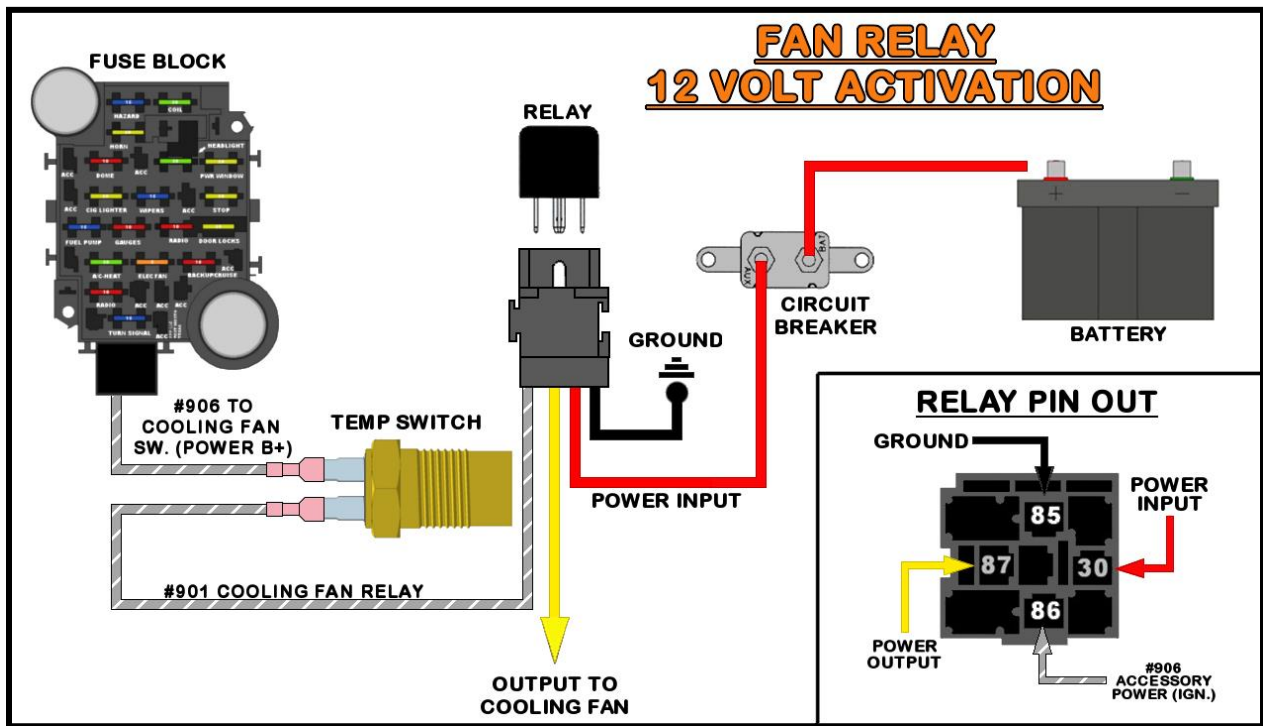

RIGHT TURN / PARK LIGHT & HEADLIGHT

The connections on the right/passenger side of the vehicle all connect in the same manner as those on the left/driver's side. The only difference you will find is the turn signal wire for the right turn signal is a different color than the one used for the left turn signal. The right turn signal will be:

BLUE: 18-gauge wire, printed **[FRONT LIGHT SECTION] #925 RIGHT FRONT TURN SIGNAL**; this wire is the turn signal power and goes to the turn signal switch. This wire has interrupted switched power from the turn signal flasher any time the right turn signal is activated, and the ignition is in the ON position. It also receives interrupted battery power from the hazard flasher any time the hazard switch is in the ON position.

FRONT LIGHT SECTION SCHEMATIC

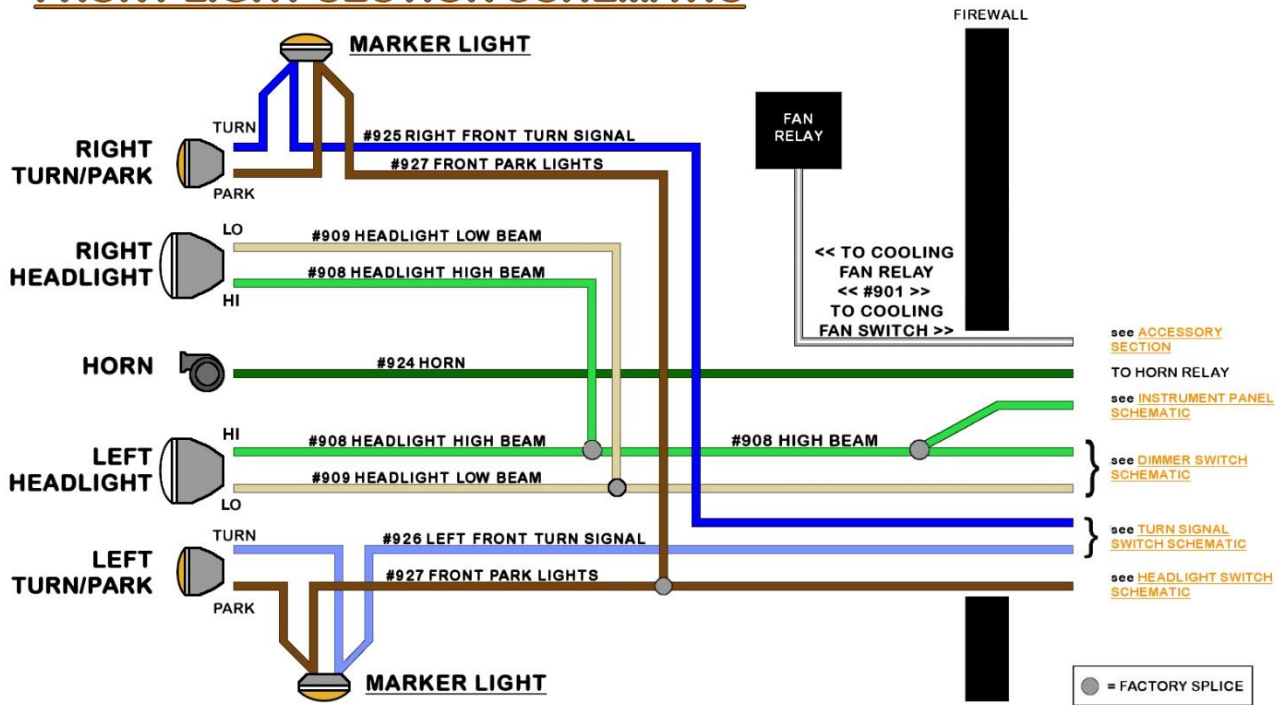

WITH DUAL/QUAD HEADLIGHTS

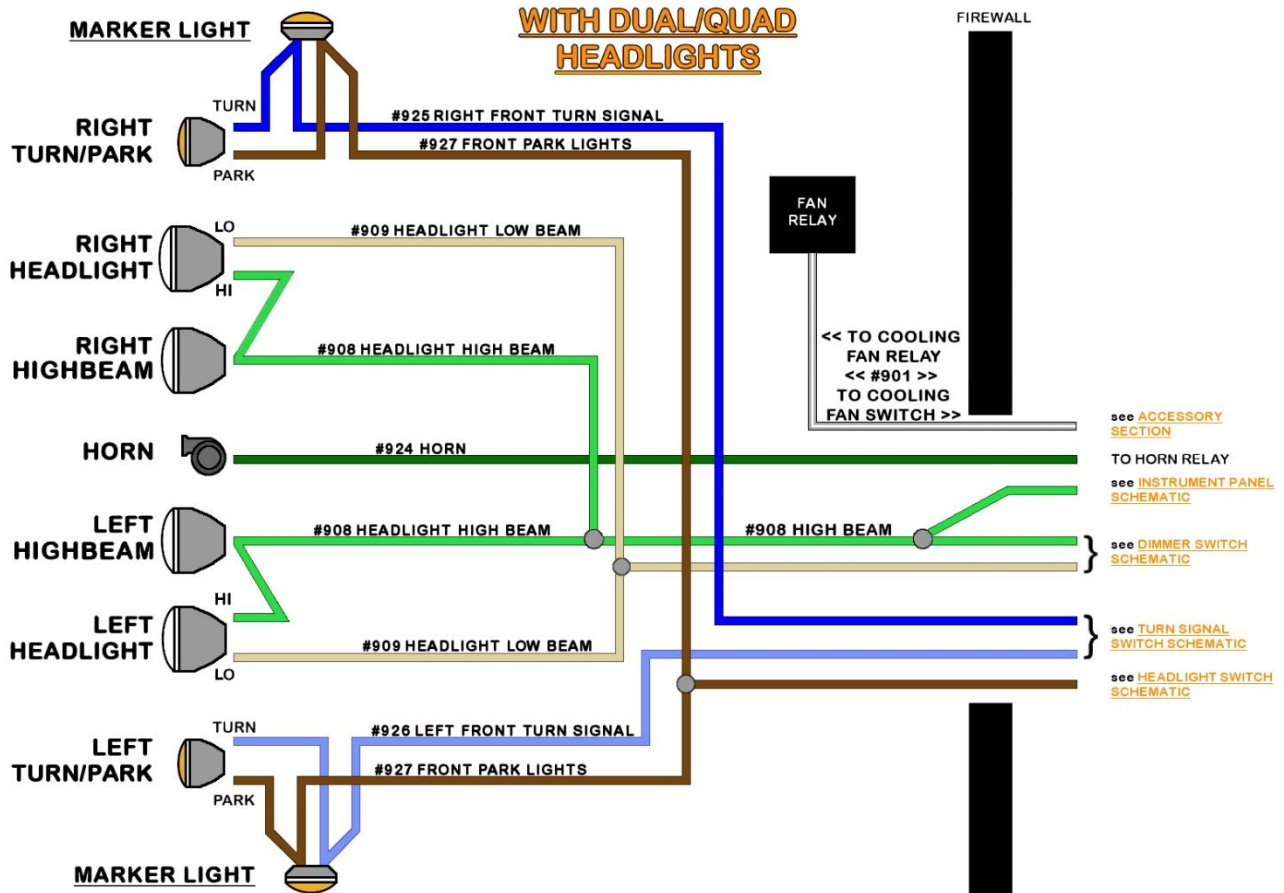

ENGINE SECTION



Engine Section consists of eight wires, some of which may or may not have already been re-routed to other places in the vehicle. These wires connect to the oil pressure and coolant temperature sending units for gauges or indicator lights, the coil or ignition system, an A/C compressor, and an electric choke on a carburetor. There are also wires for those with hydraulic brake switches.

If you re-routed the brake switch wires of your harness inside the vehicle because you have a pedal mounted switch, your brake switch instructions will follow later in the manual. Be aware, the large gauge Purple wire in this section wire is for the Starter Solenoid and will be covered in the **Start/Charge** portion of this manual.

All wires of the **Engine Section** have ample length to account for the numerous ways components can be mounted inside an engine compartment. For example, an ignition box mounted on the inner fender requires more length of wire than a firewall mounted coil.

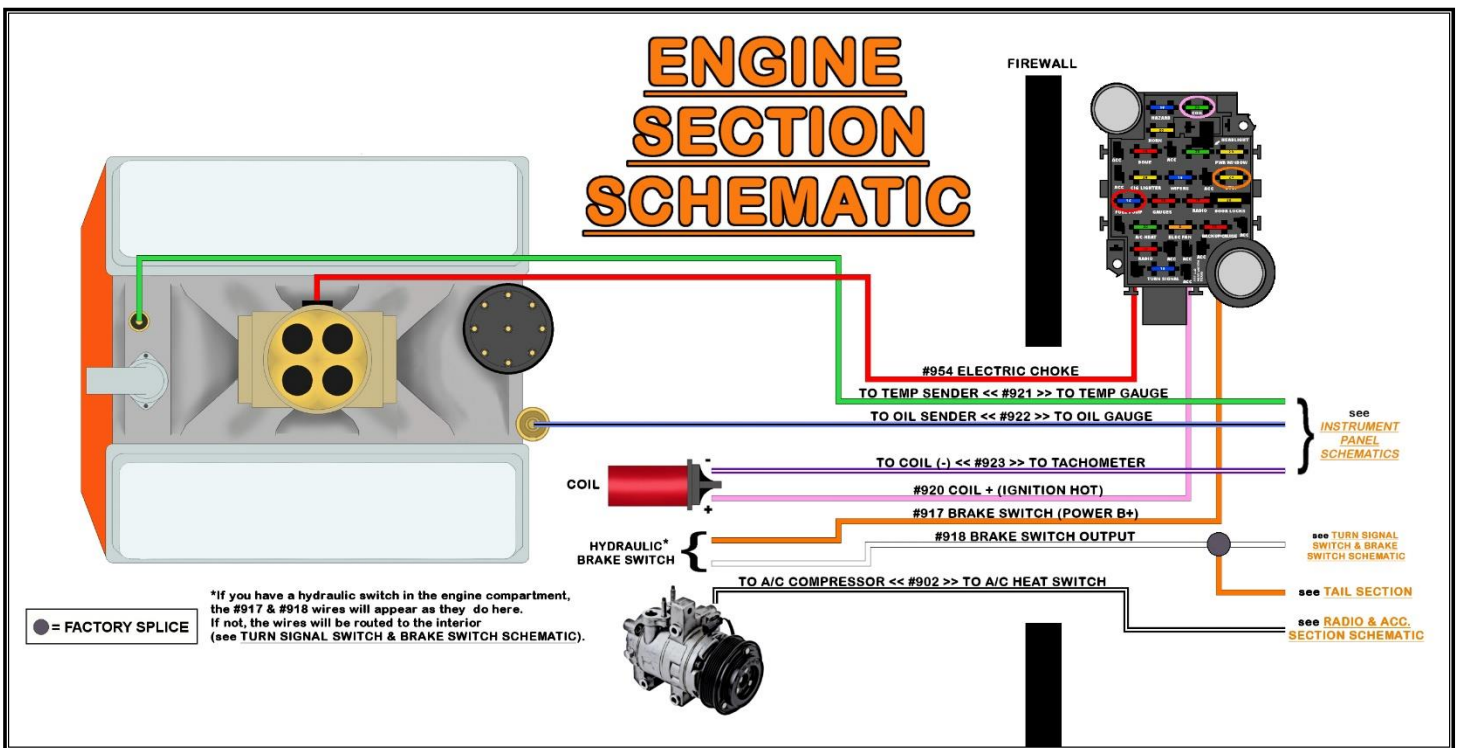

BRAKE SWITCH (Hydraulic)

The location of the brake switch will vary from vehicle to vehicle as this connection depends on the style of switch your vehicle uses.

Hydraulic switches, like **Painless #80171** (shown), will be mounted in the engine compartment usually near or on the master cylinder. A mechanical switch, like **Painless #80172 (2-pin)** or **#80176 (4-pin)**, also included in our torque converter lockup kits **#60109 & #60110**, will be mounted on or near the pivot point of the brake pedal.



There are two wires found in the Painless chassis harness for proper Brake Switch connection, they are:

ORANGE: 14-gauge wire, printed **[ENGINE SECTION] #917 BRAKE SWITCH (POWER B+)**; which provides power from the 20-amp STOP fuse. This wire will always have power.

WHITE: 16-gauge wire, printed **[ENGINE SECTION] #918 BRAKE SWITCH OUTPUT**; this wire supplies power from the brake switch to the brake lights. This wire goes into a splice with 2 other wires. This splice can also be seen in the [Turn Signal Switch & Brake Switch Schematic](#) on [page 81](#).

- Route the brake switch wires to the brake switch and connect using the loose piece insulated terminals provided in the parts kit.

COOLANT TEMP SENSOR

LT. GREEN: 18-gauge wire, printed << [ENGINE SECTION] TO TEMP SENDER << #921 >> TO TEMP GAUGE [INSTRUMENT PANEL SECTION] >>; this wire sends a resistive ground signal to the engine coolant temp gauge. If you are using an aftermarket mechanical gauge, this wire is not needed. See the [Engine Section Schematic](#) above.



The coolant temp sending unit or temp switch can be mounted in the intake manifold or the side of either cylinder head. These will have a peg, tab, or threaded post to connect to, as seen in the photos on this page. Terminals have been provided for those with the style of sensor seen below. Your factory notched connector will need to be re-used; rolover crimpers will be needed to install this terminal.

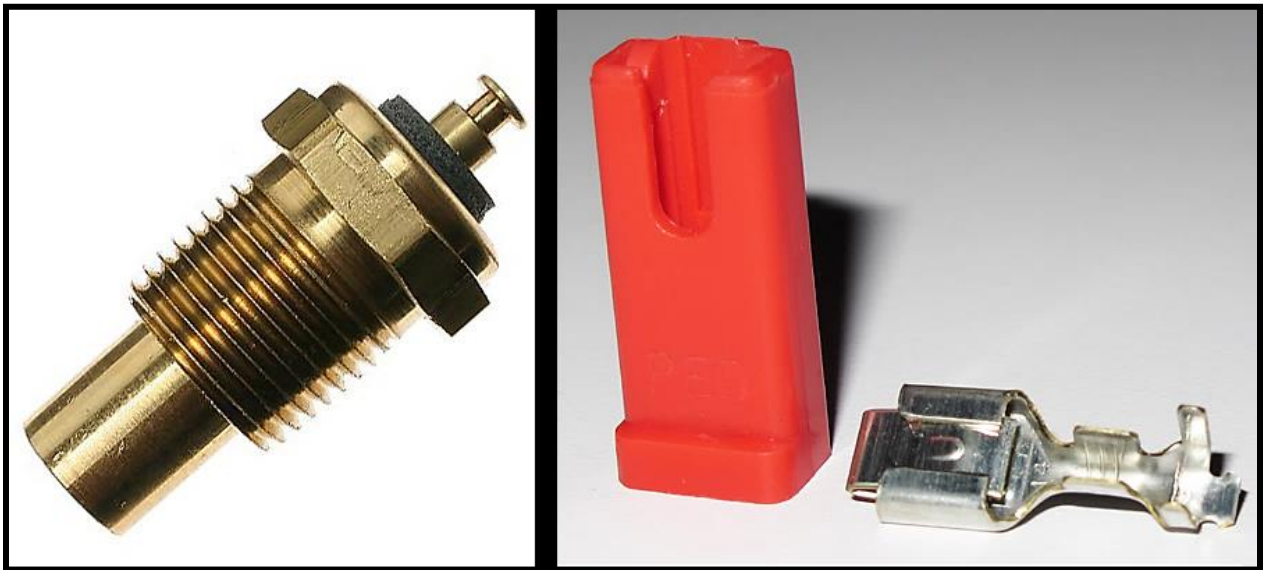

Two-wire sending units found on vehicles with indicator light clusters, meaning there is no temp gauge only a temp light, usually require a chassis ground source on one side of the sending unit. Trace your factory harness or better yet, consult a wiring diagram from your year/make/model vehicle to see what your requirements are.

Two-wire temperature sensors on fuel injected engines are for engine computer input, not for gauge signal.

Also, if connecting to an engine in a vehicle that has electric cooling fans, make certain you know the difference between the coolant temp sensor and the electric fan thermostatic switch; both sensors can look identical.

If you are installing a new temp sensor or are unsure of the temp sensor currently mounted in your engine, make sure there is no sealant tape on the sensor threads. The tape can interfere with the ground source the sensor needs to read correctly. Thread compound should be used instead.

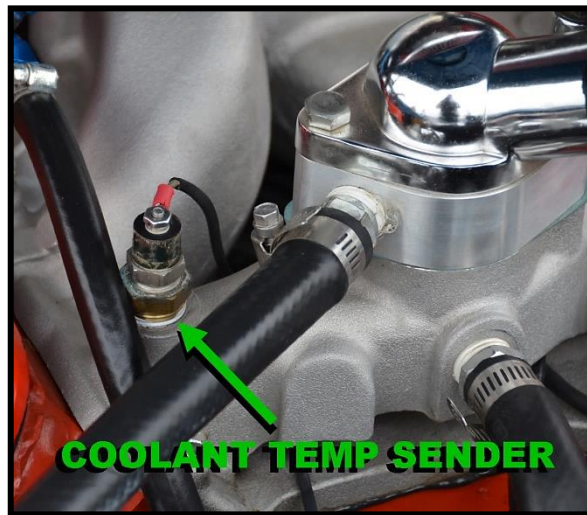

- Route this **LT. GREEN #921** wire to the coolant temp sensor, cut to length, strip $\frac{1}{4}$ " insulation, and crimp on the appropriate terminal for your connection, and connect.

OIL PRESSURE SENSOR

LT. BLUE/BLACK: 18-gauge wire, printed << [ENGINE SECTION] TO OIL SENDER << #922 >> TO OIL GAUGE [INSTRUMENT PANEL SECTION] >>; this wire sends a ground signal to the oil pressure gauge. If you are using an aftermarket mechanical pressure gauge, this wire is not needed. See the [Engine Section Schematic](#) on [page 38](#).

The oil pressure sending unit will generally be located near the oil filter or on the back of the block behind the intake manifold.



- Route this **LT. BLUE/BLACK #922** wire to the oil pressure sending unit, crimp-on the appropriate terminal for your connection, and connect.

Terminals have been provided for those with the style of sensor seen below. Your factory notched connector will need to be re-used; rollover crimpers will be needed to properly install this terminal.

Two-wire sending units found on vehicles with indicator light clusters, meaning there is no oil gauge only an oil light, usually require a chassis ground source on one side of the sending unit. Trace your factory harness or better yet, consult a wiring diagram from your year/make/model vehicle to see what your requirements are.

If you have a 2-wire sensor on a newer, fuel-injected, donor engine, it will not work for your pressure gauge. Two-wire sensors on fuel injected engines are for fuel pump control and are not designed for oil pressure gauge readings. These types of sensors are generally found on GM TBI and TPI engines.

ELECTRIC CHOKE

RED: 18-gauge wire, printed [ENGINE SECTION] #954 **ELECTRIC CHOKE**; this wire provides a switched ignition power source to the choke from the 15-amp FUEL PUMP fuse. It has power when the ignition switch is in the ON/RUN position.

When you turn your key to the "ON/RUN" position, the voltage this wire carries heats the bi-metal spring called the "choke thermostat." This spring will unravel as it is heated causing the choke to slowly open. When the ignition is turned to the "OFF" position, power is no longer on this wire, causing the spring to begin to cool and contract, closing the choke.



- If you do not have an electric choke, you do not need this wire and it can be capped off and stowed. **If you are using a Turbo 400 transmission, see the instructions below before terminating the #954 wire.**
- Route the **RED #954** wire to the + terminal of the electric choke, install the supplied terminal and connector, and connect. **If you are using a Turbo 400 transmission, and a throttle switch is in the engine compartment, see the instructions below before terminating the #954 wire.**
- Double up the cut off piece of **#954** at the choke to provide power to the Turbo 400 kickdown throttle switch.
- Ensure the choke is properly grounded (the ground wire is not supplied in the Painless harness) before continuing with the installation. This is normally provided with the carburetor.

Turbo 400 Transmission

The Turbo 400 transmission requires a 12v power source to downshift the transmission under wide-open throttle. This is done using a throttle switch either located on the accelerator pedal inside the vehicle or on the throttle linkage on top of the engine.

- Double up the cut off piece of **#954** at the choke. Route this cutoff piece of **#954** to one side of the throttle switch and cut to length. Use terminals from the parts kit to connect the wire.
- If you have a factory, accelerator pedal mounted switch, you can use a switched power source inside the vehicle or you can route the cutoff piece of **#954** to the interior, connect at the throttle switch, and then route it back out to the transmission.

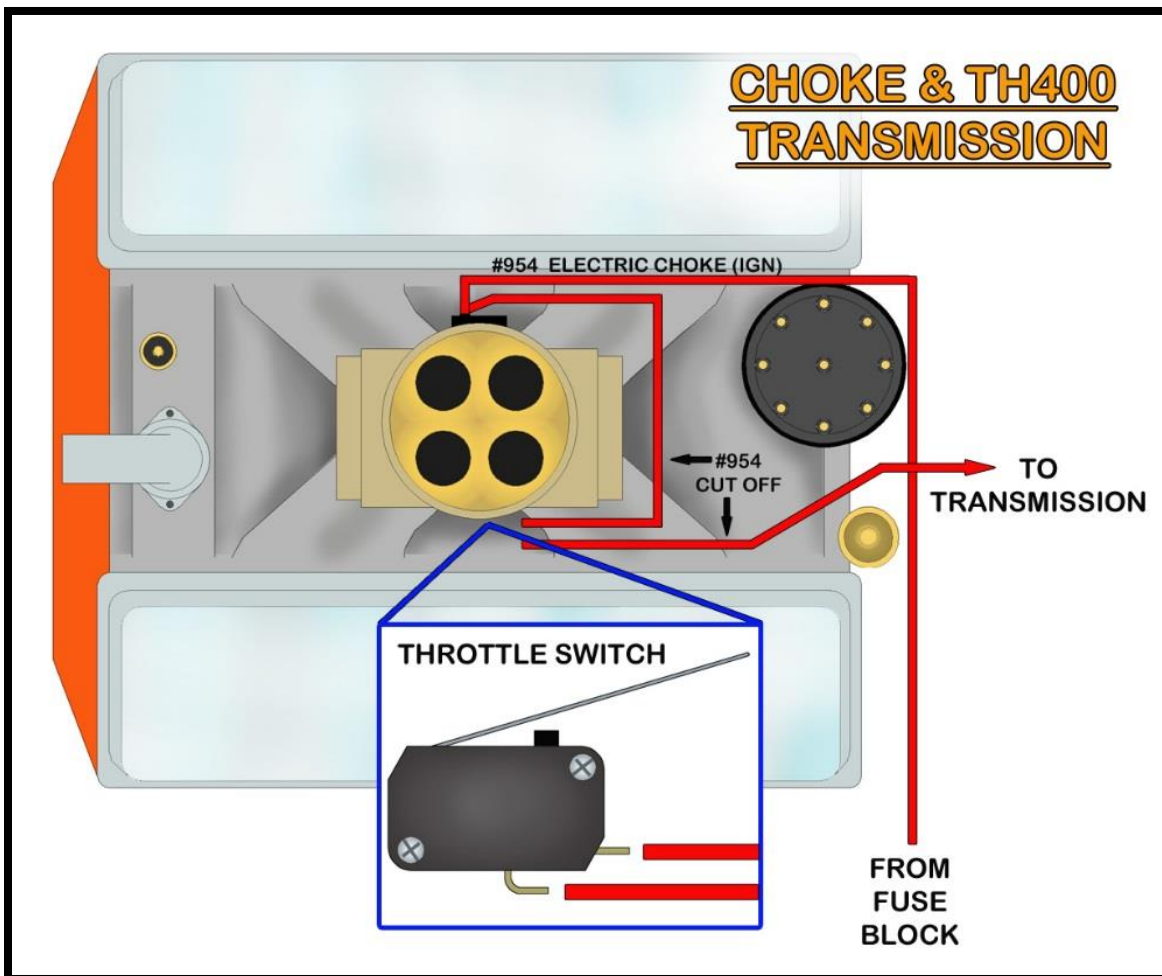
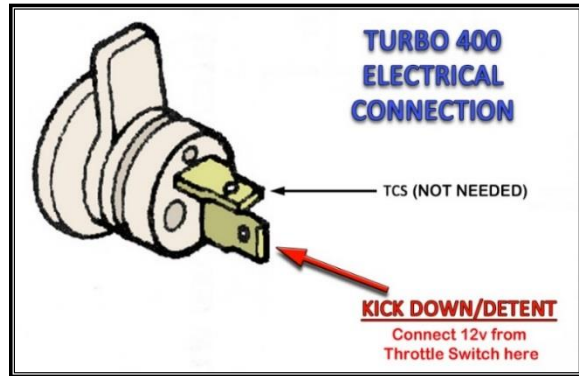

COIL

A single wire, coming from the fuse block, supplies power to the coil/ignition system. The connection of this wire varies depending on what ignition system (factory or aftermarket) you use. The wire needed to supply a switched ignition power source is:

PINK: 14-gauge wire, printed **[ENGINE SECTION] #920 COIL + (IGNITION HOT)**; this wire comes from the 30-amp COIL fuse. This wire has power anytime the ignition switch is in the ON and START positions. This wire provides the coil/ignition system with switched power in 1 of 4 ways:

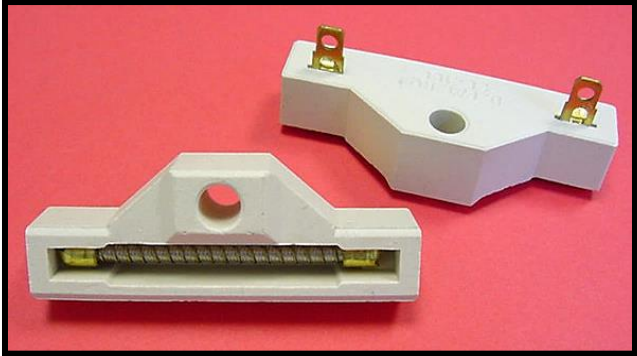
- If the Coil you are using is not internally resisted, a ballast resistor, along with the installer provided bypass wire shown on [page 45](#), will be required. If a coil is not internally resisted and a ballast resistor is not used, the coil will overheat within a few minutes to the point that it will no longer work. A ballast resistor can be obtained at your local parts store using part number **RU11**. See the [Ballast Resistor Connection Diagram](#) on [page 45](#).
- 
- HEI coils, internally resisted coils, and most aftermarket ignition boxes do not require the use of a ballast resistor. The **#920** wire connects directly to the + side of the coil. See the [Coil Connection \(NO Ballast Resistor\) Diagram](#) on [page 45](#).
 - If you use an aftermarket ignition box, such as an MSD, Accel, etc., this **PINK #920** wire will supply the ignition box with the switched power source it requires. This wire goes to the aftermarket ignition box and not the Coil; the ignition box will provide the Coil + connection. This **#920** wire may need to be pulled from the **Engine Section** and routed to where the box is mounted. See the ignition box manufacturer's instructions for a specific connection point of this power source. [MSD Ignition Connection](#) on [page 46](#) has been provided.
 - If you have converted to fuel injection, are using a standalone harness, such as a Painless fuel injection harness, and coil power is supplied through the fuel injection harness, in LT1/LS1 and newer applications, this **PINK #920** wire provides the fuel injection harness with the switched power source the harness requires. If you use a Painless fuel injection harness, this **PINK #920** wire will connect to the open-ended **PINK** wire of the fuel injection harness labeled **"IGN"** or **"Fuse Block IGN."**
 - Route this **PINK #920** wire to its proper connection point and cut to length, install the appropriate terminal for your connection, and connect.

Tachometer

PURPLE/WHITE: 18-gauge wire, printed << [ENGINE SECTION] TO COIL (-) << **#923** >> TO TACHOMETER [INSTRUMENT PANEL SECTION] >>; this wire sends a tachometer signal from the coil to the gauge cluster. This wire only needs to be connected if you are using a tachometer (factory or aftermarket). See the [Engine Section Schematic](#) on [page 38](#). If you do not have a tachometer, this wire may be removed from the harness. Depending on your ignition system (factory or aftermarket), or use of fuel injection, the connection of this **#923** wire can vary:

- Standard factory type installs with an HEI distributor, or external coil ignition systems, require the **#923** wire to be connected to the negative (-) side of the coil. Refer to the diagrams on [pages 45 – 46](#) for proper connection.

Terminals and a factory-style connector are supplied to allow connecting to the (-) side of an HEI Coil (seen in the photo at right). Rollover crimpers are needed to install this terminal. Insulated terminals in the parts kit are supplied to make other connections.

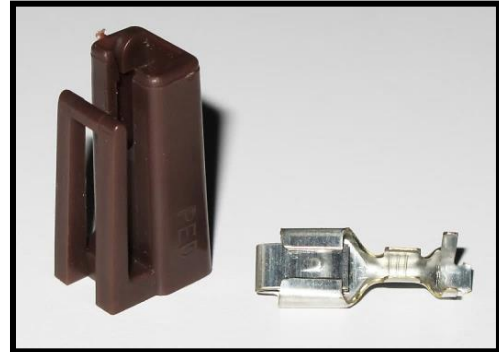

- If you are running fuel injection and the tach output wire of the fuel injection harness does not reach the tachometer, this **#923** wire will connect to the tach output wire from the ECM.
- If an aftermarket ignition box is being used, such as an MSD, Accel, etc., this **#923** wire will connect to the tach output found on the ignition box. Refer to the [MSD Ignition Connection](#) on [page 46](#) and the ignition manufacturer's installation procedure.
- Route this **#923** tach signal wire to its proper connection point and cut to length, install the appropriate terminal for your connection, and connect.

Use one of the following four diagrams to properly connect the coil power (#920) and tachometer (#923). Not shown in the diagrams are the wire(s) connecting the coil and the distributor, these are not included.

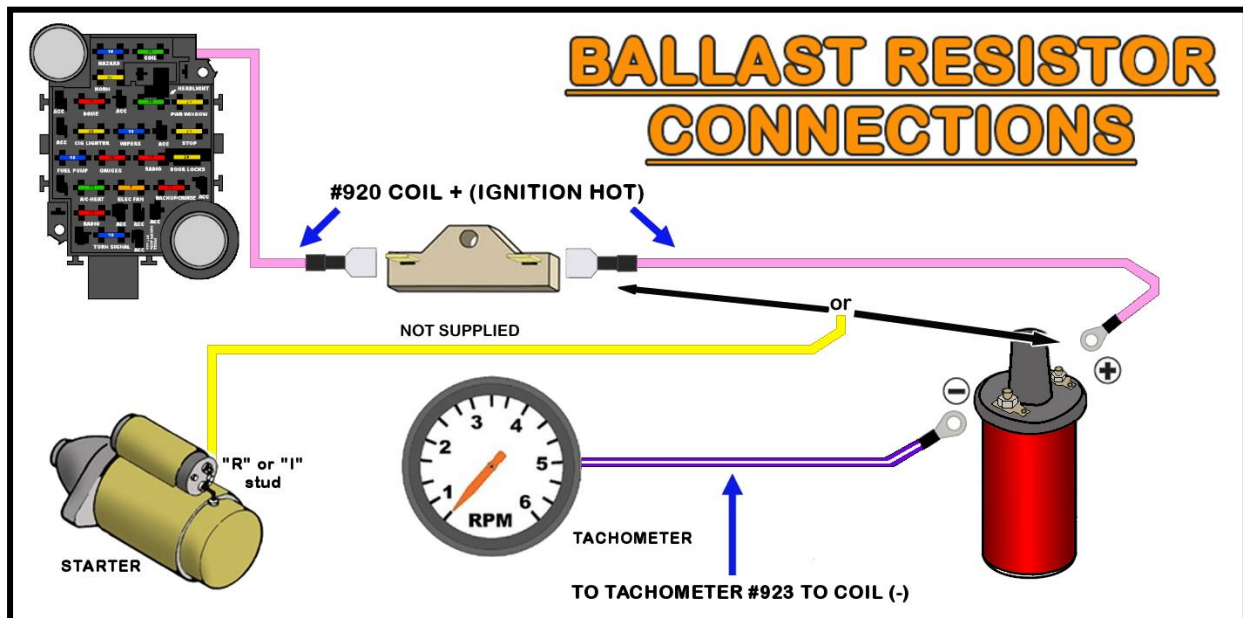
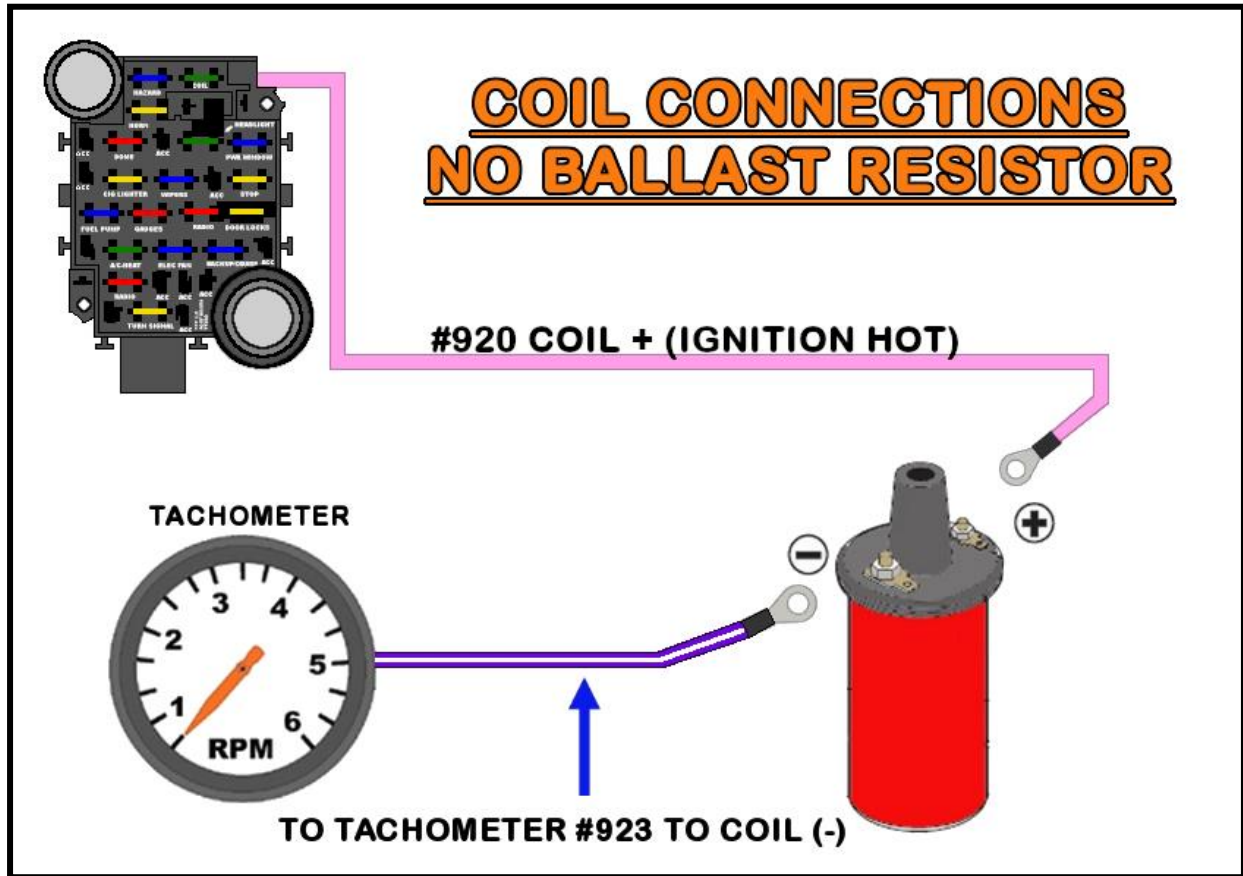

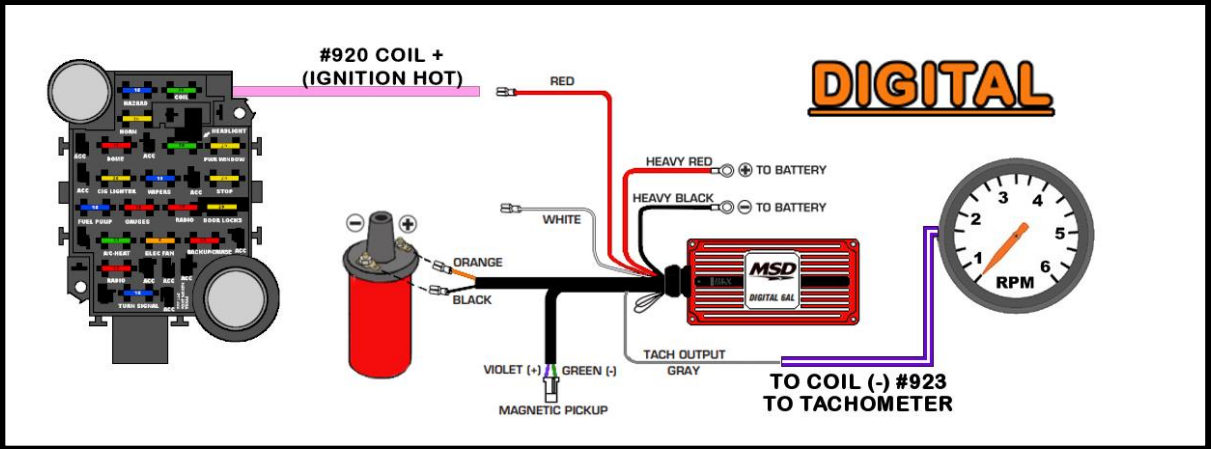
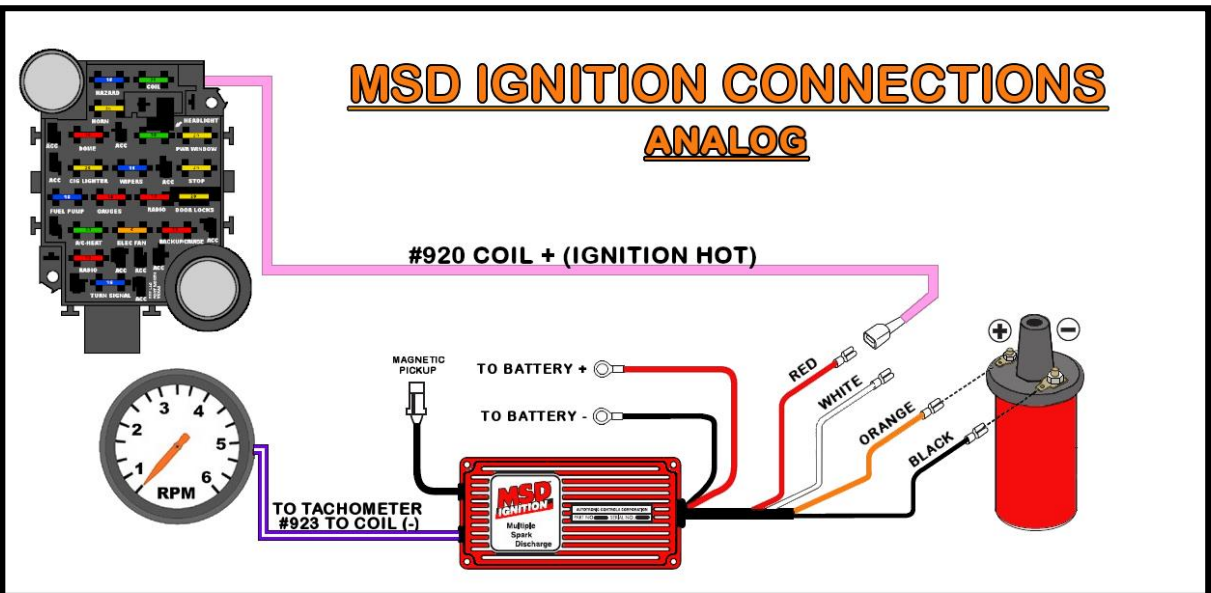
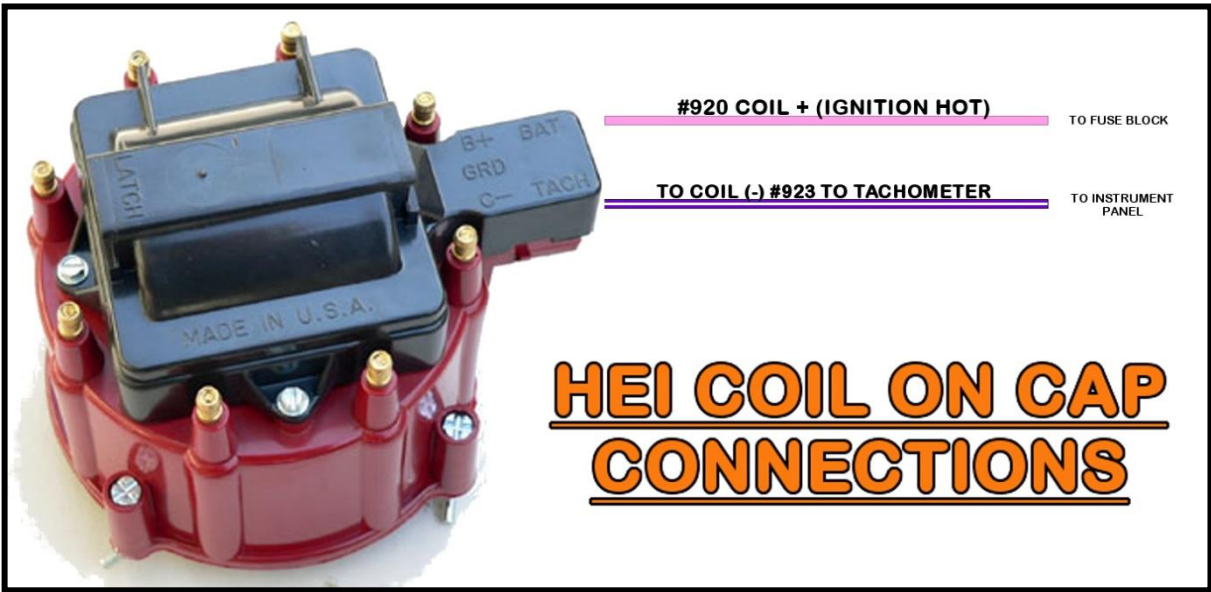

A/C COMPRESSOR CLUTCH

Before connecting this wire, see the A/C – Heat Section on [pages 115 – 117](#) for diagrams and further details on how to connect a factory or aftermarket system.

BLACK/WHITE: 14-gauge wire, printed << [ENGINE SECTION] TO A/C COMPRESSOR << #902 >> TO A/C HEAT SWITCH [ACC. SECTION SWITCHES] >>; this wire is intended to provide power to the A/C compressor clutch. This wire comes from the A/C switch inside the vehicle to the binary or trinary safety switch and then to the compressor.

This wire can also be used to provide power to the blower motor on only vehicles that power the blower through the bulkhead instead of a separate harness that exited the passenger side of the firewall.

- In the engine compartment, route the **#902** wire to your binary or trinary safety switch if one is being utilized. In most cases with aftermarket systems, this will be mounted near the condenser on the core support. Cut the **#902** wire to length and connect. Attach the cut-off portion to the other pin of the pressure switch and route it to the A/C compressor clutch and connect.

Those using a trinary switch, use the diagram on [page 117](#) to wire the fan control portion of the switch. Cut off wire or wire supplied by a separate fan relay harness will be needed as this chassis harness does not include this wire except **#901** as shown.

This wire can be repurposed or removed if you are not using an A/C system.

This wire will only have power when connected to a power source inside the vehicle.

START/CHARGE SECTION

The Start/Charge Section consists of three wires for connections to the alternator, starter solenoid, and inline MIDI fuse (included with the kit). Locations of all these components vary from vehicle to vehicle so no specific routing instructions can be given.

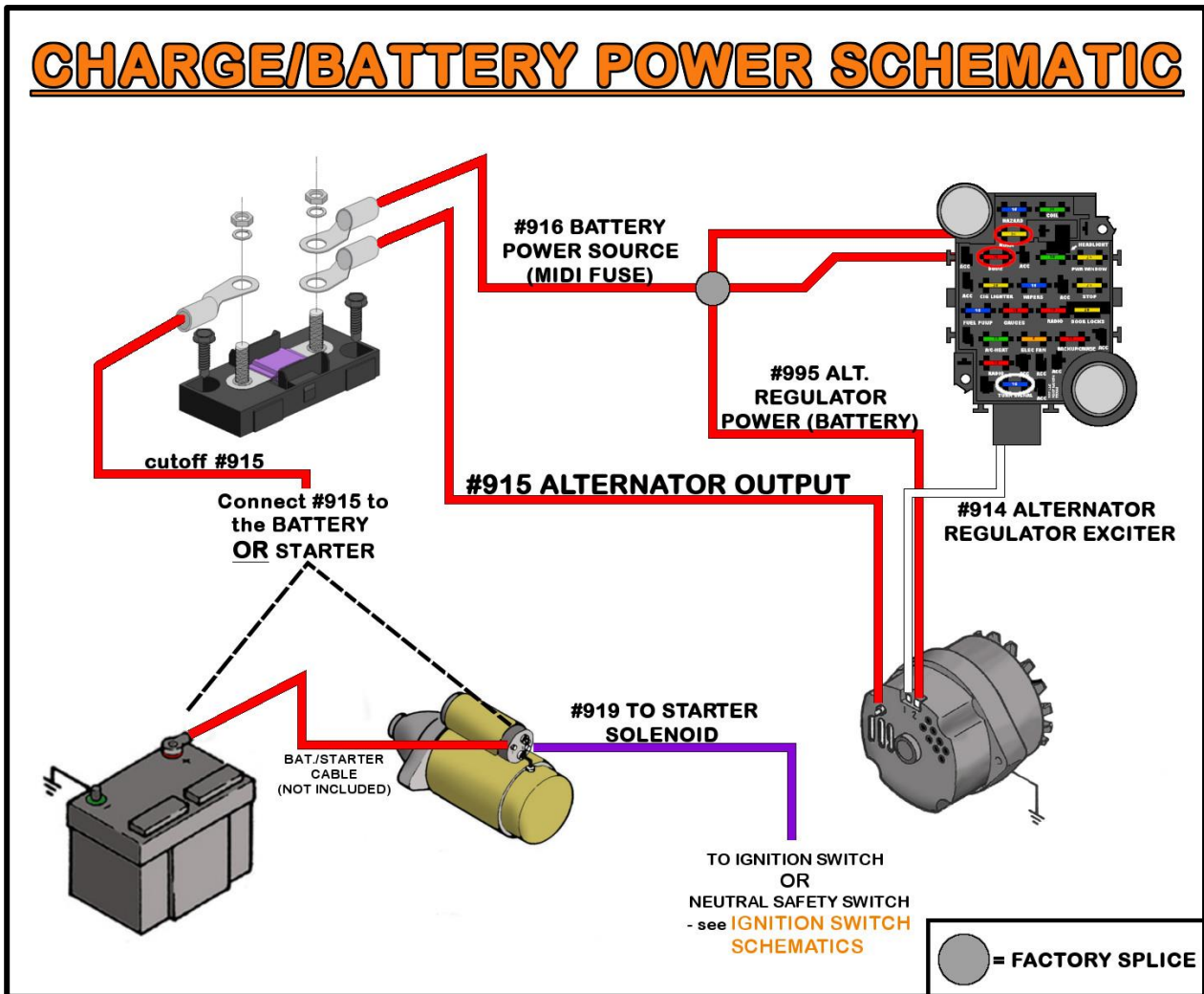

Locate the bag kit provided with the Painless harness kit labeled "ALTERNATOR." This bag kit contains the hardware needed to make the appropriate connections to the alternator as well as a covered inline fuse holder.

ALTERNATOR

The alternator connections vary depending on the alternator your vehicle currently has installed. The alternator may also need to be removed to gain access to the connection points.

The one connection all alternators have in common is the output post. This sends power from the alternator to the battery. This connection is made using the large gauge **RED** wire rolled in the kit, it is:

RED: 6-gauge wire, no printing, **#915 ALTERNATOR OUTPUT**; this wire provides power out of the alternator to the MIDI fuse and from the MIDI fuse to the battery. This wire is not part of the harness but is a separate, rolled piece of wire provided with the kit. When connected, this wire always has power from the battery. See [Charge/Battery Power Schematic](#) on [page 48](#).



- Locate the rubber alternator boot and a large, un-insulated ring terminal from the “ALTERNATOR” bag that has the right size opening for your alternator post. A piece of the provided red heat shrink may be used along with the boot or just by itself over the terminal crimp if the alternator boot is not desired.



- If the rubber boot is being used, the end will need to be cut, as shown in the photo to the right, to allow the large gauge wire to pass through.
- If the heat shrink is being used, slide it onto the **#915** wire, followed by the rubber boot. A small amount of lubricant such as WD-40 may be applied on the inside of the rubber boot to allow the boot to slide down the wire easier.
- With the boot on, strip about $\frac{3}{8}$ ” of insulation from the charge wire and crimp the ring terminal on. You can use a hammer crimper if your hand crimper will not accept this large gauge wire/terminal.
- Connect this wire to the B+/Output stud on the alternator. Once the nut on the output post stud has been tightened, slide the boot over the nut and ring terminal installed on the alternator.



If your vehicle has an aftermarket, **ONE WIRE ALTERNATOR**, meaning it does not require a switched 12v source or regulator connections, or if the Painless or other aftermarket fuel injection harness you are using has an alternator connector, **then this output wire is the only wire used in this section at the alternator.**

Locate the 2 wires intended for alternator regulator connections; they will be grouped together in the **Alternator Section**. These wires are:

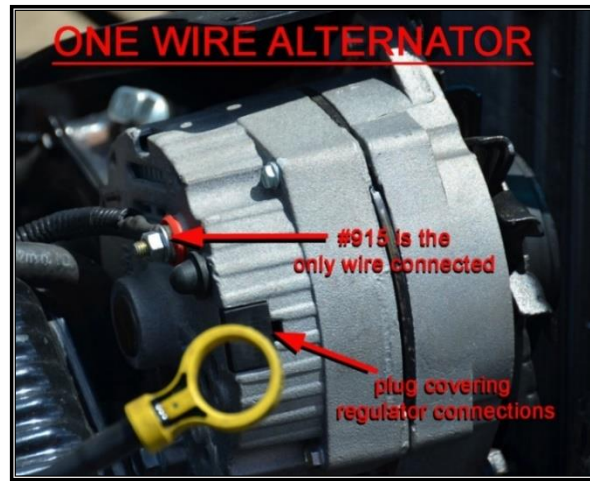

RED: 14-gauge wire, printed **[ALTERNATOR] #995 ALT. REGULATOR POWER (BATTERY)**; this is the sense wire, it provides a battery power source, or voltage sense, that all voltage regulators require. This wire always has power and comes from the large battery supply splice in the harness. **This wire will not be needed if you have a one wire alternator or a GM CS series alternator.** See the various alternator illustrations on [pages 52 – 64](#) and the [Charge/Battery Power Schematic](#) on [page 48](#).

WHITE: 14-gauge wire, printed **[ALTERNATOR] #914 ALTERNATOR REGULATOR EXCITER**; this is the indicator light wire and has switched ignition power from the fuse block. **This wire will not be needed if you have a one-wire alternator.**

If you have a one wire alternator, and only if you have a one wire alternator, you need to insulate the ends of these wires and stow them in the harness, **THEY ARE POWER WIRES**. **#995** may also be connected to the output post of the alternator to avoid removing it from the harness since this wire goes into the big battery power splice.

CHARGE INDICATOR LIGHT

Those wanting to add a charge indicator light will need to re-route the **WHITE #914** wire found in the **Alternator Section** of wires. This wire will be connected to the light and then out the other side of the light to the alternator voltage regulator. The way the light will function is this:

Electrical current moving from the fuse block, through the filament, and out to the alternator causes the light to illuminate. This light illuminates when the key is in the ON/RUN position and the alternator is not charging because the engine is not running or when the alternator is not working properly. Once the alternator is charging, the voltage regulator no longer needs the switched ignition voltage supplied by the **#914** wire, which stops the current flow. Since power is no longer flowing through the filament, the bulb does not illuminate.

If you are using a one-wire alternator, a charge light cannot be installed since you do not have an alternator exciter wire going to the regulator.

- Connect the **WHITE #914** wire to one side of the light; the remainder of **#914** connects to the other side of the light to provide power out to the voltage regulator. See the diagram below.

It is also recommended, but not necessary, to wire in a 15-ohm, 2-watt resistor between the power in and power out, as seen in the diagram below. This provides enough power to the voltage regulator to allow the alternator to still charge in the event the bulb burns out. This resistor can be found online through electronic component suppliers such as Mouser or Allied Electronics under part **#OY150KE**.

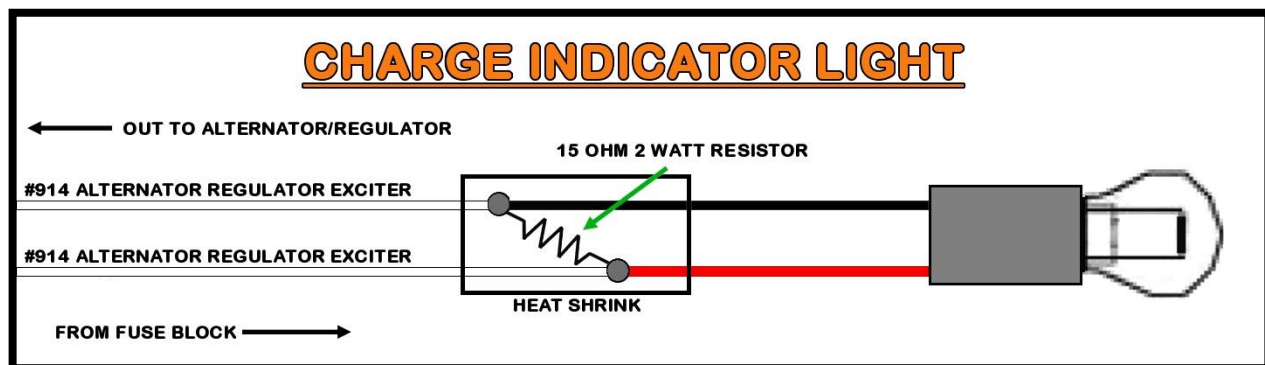
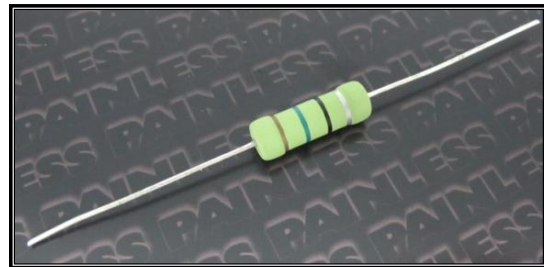

The remaining alternator connections vary based on which alternator is being used. Choose the alternator that best represents the alternator found on your vehicle from those on the next few pages. Then, follow the instructions provided for your alternator.

GM SI SERIES ALTERNATORS

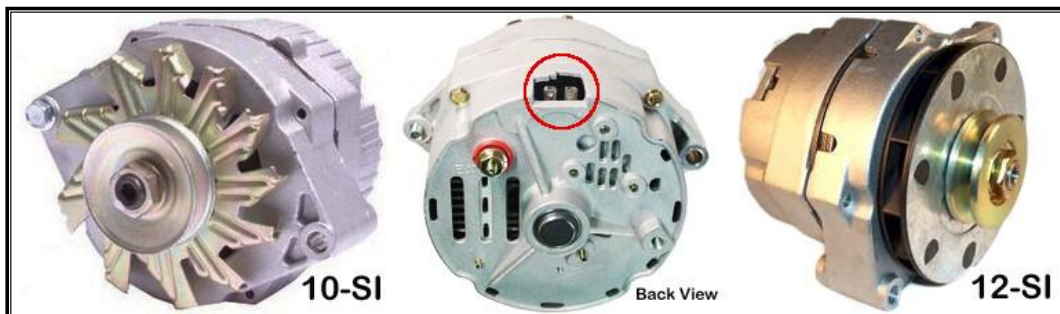

The 10-SI and 12-SI alternators are easy to identify. They have an external fan behind the pulley (the 12-SI has enclosed style fan blades) and a 2-pin connection. This 2-pin connection is circled on the second example in the image above. These are also commonly referred to as “Delco” or “Delcotron” alternators.

The two wires, **RED #995 REGULATOR POWER (BAT)** and **WHITE #914 ALTERNATOR REGULATOR EXCITER**, connect to the two posts on the back edge of the alternator.

- Route the two wires to the numbered 1 & 2 terminals on the alternator and cut to length. Strip $\frac{1}{4}$ " of insulation from both wires.
- A factory-style connector and terminals, seen in the photo to the right, are provided in the “ALTERNATOR” bag. Crimp a terminal onto each of the two wires.
- Insert the wires into the connector as shown in the diagram below. When the terminal pin-out is complete, plug the connector into the alternator.



You may experience engine run on. This is caused when the alternator back feeds voltage down the **#914** wire after the key has been turned off. This allows the ignition system to still function causing the engine to continue running even though the key is turned off or even removed from the ignition. If this should happen, unplug the alternator connector to shut the engine off. If you experience this, a remedy has been provided.

As shown in the photo above and the diagram below, a diode, splices, and heat shrink are provided. If engine run-on occurs, simply install the diode as shown. When the diode is installed in line with the **#914** wire **with the stripe towards the alternator** it lets current flow towards the alternator, but not away from the alternator back feeding the ignition system, thus fixing the run-on issue.

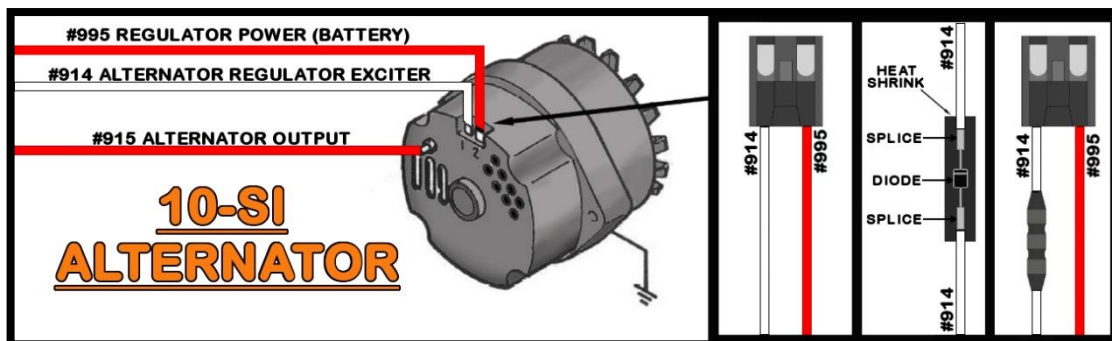

GM CS-130 SERIES ALTERNATORS

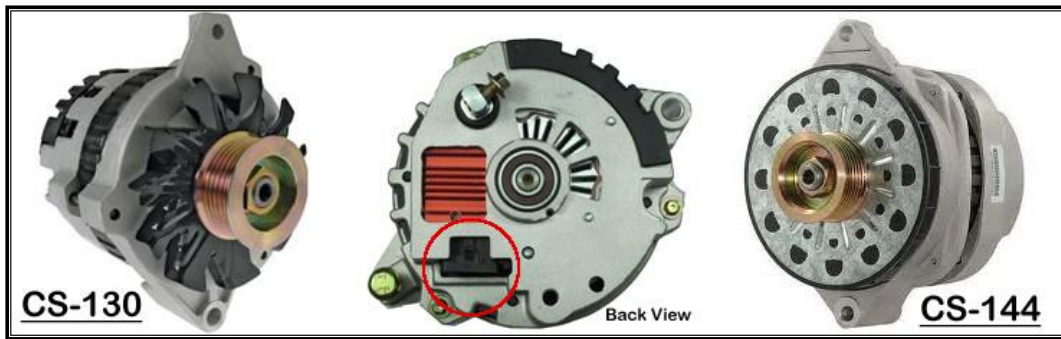

The CS-130, CS-121, and CS-144 alternators closely resemble the SI series alternators. They have an external fan behind the pulley and, generally, a plastic casing on the side and back. These alternators have a 4-pin, sealed connector, shown in the photo below and circled in the image above. The regulator will be marked P, L, S, F. This type of alternator was used on GM TPI and LT1 fuel injected engines among other late 1980s to mid-1990s GM vehicles.

The two wires **RED #995 REGULATOR BATTERY POWER** and **WHITE #914 ALTERNATOR EXCITER**, connect to the regulator on the back of the alternator.

- Route the two wires to the connector on the alternator and cut them to length. Strip $\frac{1}{4}$ " of insulation from both wires.
- The factory 4-pin alternator connector from a factory GM harness (see photo to the right), is needed. It is not included with this Painless chassis harness.
- The CS-130 alternator requires a resistance on the **WHITE #914** wire. Without this resistance, the regulator on the alternator will burn up. A resistor, splices, and heat shrink, seen below, are provided in the "ALTERNATOR" bag kit. The resistor* will simply need to be installed inline on the **#914** wire as shown in the diagram on the next page.

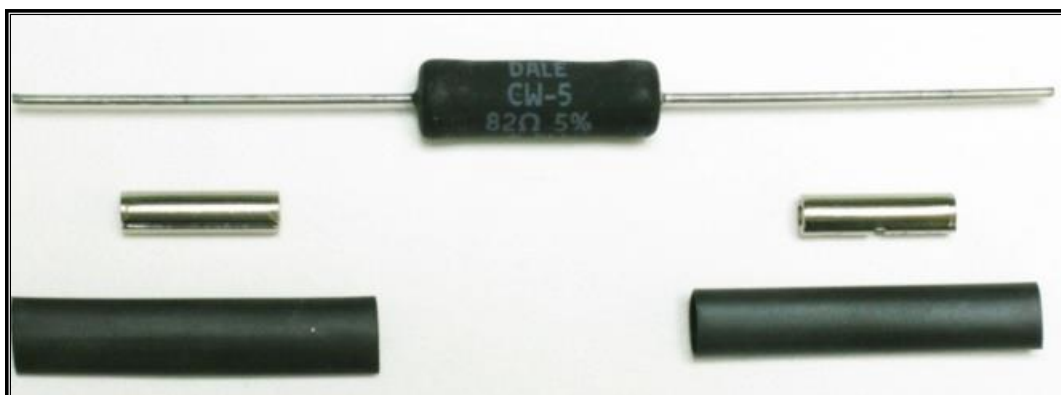
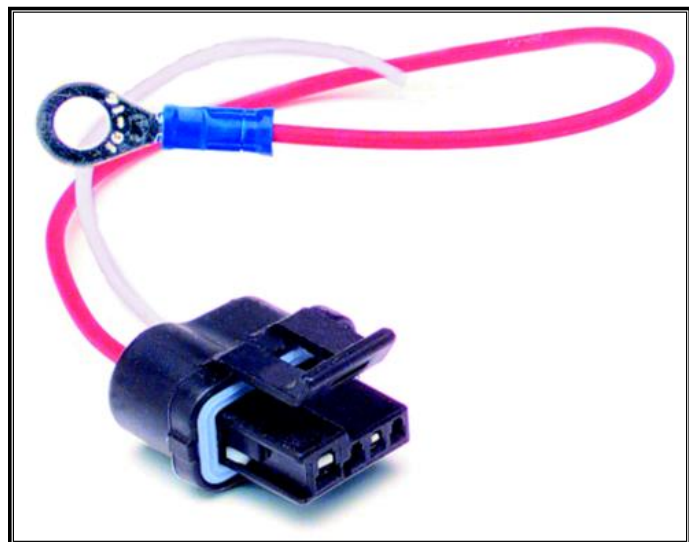

*In factory applications where this alternator was used, a charge indicator light created the necessary resistance. **For those with an instrument panel with a charge indicator light, the resistor is not needed.** However, the #914 wire needs to be routed to one side of the charge indicator light and the other side of the light then routes out to the alternator. A charge indicator light was explained in more detail on [page 51](#).

- Use 2 of the splices and heat shrink provided in the “ALTERNATOR” bag kit to splice the CS-130 pigtail to the #914 and #995 wires according to the diagram below.

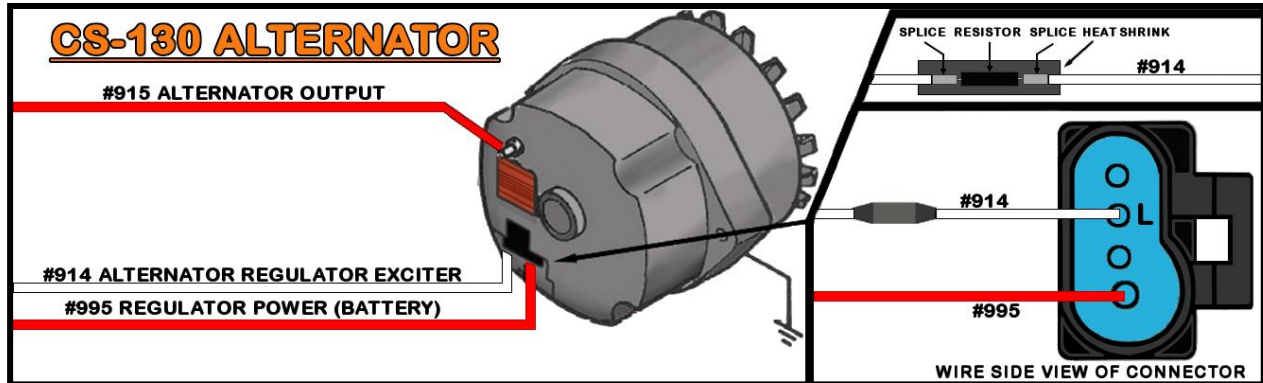

GM CS-130D SERIES ALTERNATORS

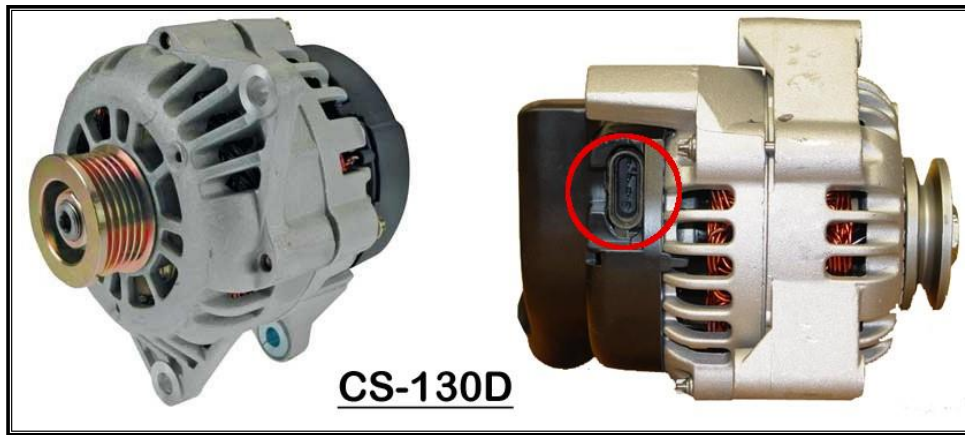

The CS-130D can be spotted by the lack of an external fan behind the pulley. These alternators have an internal fan and a plastic casing on the back. These alternators have an elongated, oval, 4-pin, sealed connector, seen circled in the image above. The regulator will be marked P, L, I, S. This type of alternator was used on many engines, including the GM LS series, Vortec, and Gen. III Vortec truck fuel injected engines.

There are two wires in the **Alternator Section**: **RED #995 REGULATOR BATTERY POWER** and **WHITE #914 ALTERNATOR REGULATOR POWER (IGN)**. For the CS-130D alternator, only the **WHITE #914** is used. The **#995** may be connected to the alternator output post or removed from the harness.

- Route the **WHITE #914** to the connector on the alternator and cut to length. Strip $\frac{1}{4}$ " of insulation.
- The factory, 4-pin alternator connector from a factory GM harness or a CS-130D pigtail purchased from Painless ([part #30705](#); see photo), needs to be used.
- The CS-130D alternator requires a switched power source to pin "I" of the regulator and a resisted power source on the wire going to pin "L" of the regulator.



Without this resistance, the regulator on the alternator will burn up. A resistor, splices, and heat shrink, seen on [page 53](#), are provided in the "ALTERNATOR" bag kit. The resistor simply needs to be installed inline on the pin "L" wire, **#914**, as shown in the diagrams on the next page.

In factory applications where this alternator was used, a charge indicator light created the necessary resistance. **For those with an instrument panel with a charge indicator light, the resistor is not needed**. However, the **#914** wire needs to be routed to one side of the charge indicator light and the other side of the light then routes out to the alternator. A charge indicator light was explained in more detail on [page 51](#).

- Using a splice and heat shrink provided in the "ALTERNATOR" bag kit, splice the CS-130D pigtail to the **WHITE #914** wire according to one of the diagrams on the next page.

Both diagrams accomplish the same task: they use the **WHITE #914 ALTERNATOR REGULATOR POWER (IGN)** wire to provide a switched power source and a resisted power source to the 2 wires of a CS-130D alternator pigtail/connector when a charge indicator light is NOT being used. Pick the method that easiest for you to understand.

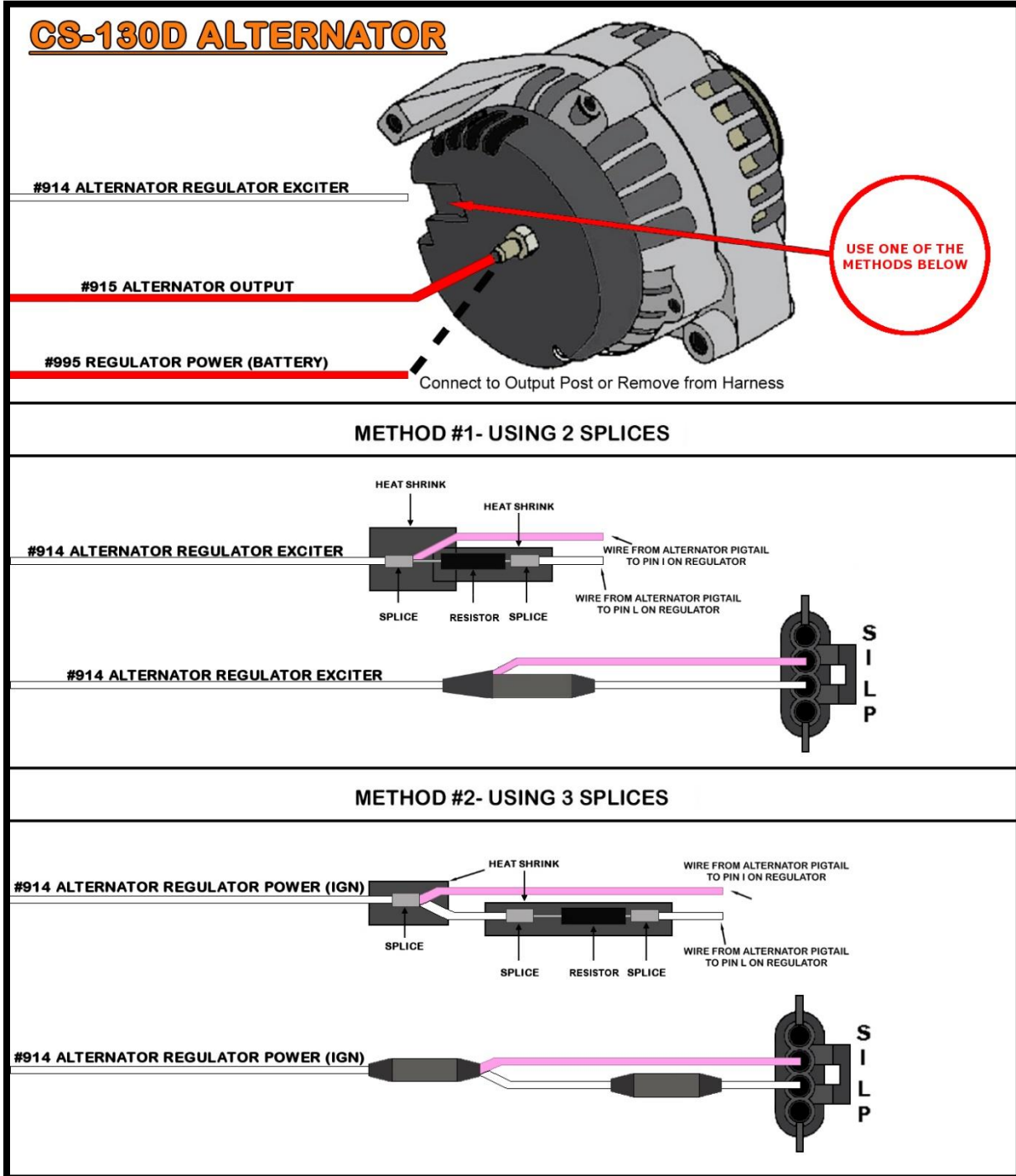

GM EXTERNALLY REGULATED ALTERNATORS

The two wires, **RED #995 REGULATOR POWER (BAT)** and **WHITE #914 ALTERNATOR REGULATOR POWER (IGN)**, connect to the regulator.

- Route the two wires of the Painless harness to the connection point on the regulator, cut to length, and strip $\frac{1}{4}$ " of insulation from both wires.
- The factory, 2-pin alternator connector, and 4-pin regulator connector from a factory GM harness need to be used. Due to a lack of usage by most customers, these connectors are not included with this Painless chassis harness. If you do not have these connectors, they can be obtained online, at a local auto parts store, or you can use the loose piece insulated terminals in the parts kit to make connections.
- Connect the **WHITE #914** wire to the "4" terminal on the regulator.
- Connect the **RED #995** to the "3" terminal on the regulator.

Two 14-gauge wires, which run from the regulator to the alternator, and a 14-gauge wire for a ground need to be provided by the installer to finish the connections. **These wires are not in the Painless harness.**

- Connect the "2" terminal on the regulator to the "R" terminal on the alternator. This was a white wire from the factory.
- Connect the "F" terminal on the regulator to the "F" terminal on the alternator. This was a blue wire from the factory.
- The last connection will be connecting a wire from the "G" post on the alternator to a chassis ground source.

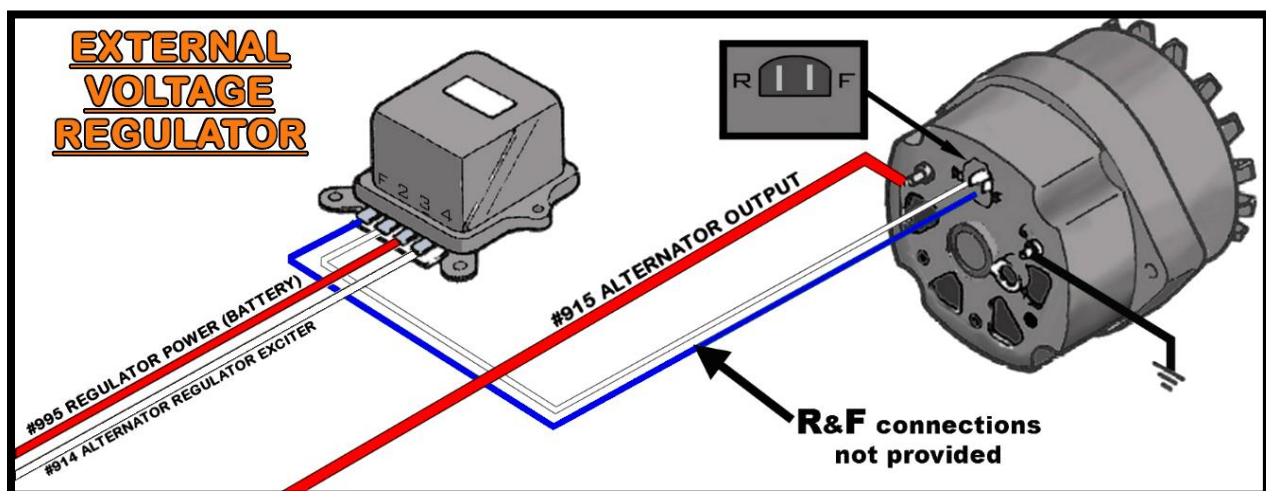

FACTORY GENERATORS

- Connect Generator ARMATURE terminal (A) to Voltage Regulator terminal A with a user-supplied 12-gauge wire.
- Connect Generator FIELD terminal (F) to Voltage Regulator terminal F with a user-supplied 14-gauge wire.
- Be sure both the generator and the voltage regulator are securely grounded. The voltage regulator may have a terminal for this purpose (labeled "G"), or you may have to ground the regulator case.
- Route **RED #916** to the MIDI fuse and cut to length.
- Connect **RED #916** to one side of the MIDI fuse along with the cut-off portion of **RED #916**.
- Route the cutoff portion of **RED #916** to the Voltage Regulator terminal B. NOTE: if the cutoff portion is too short, you will need to supply a 10-gauge wire.
- Connect the separate **RED #915** to the other side of the MIDI fuse the route to the battery or starter.
- Insulate and stow **WHT #914**.

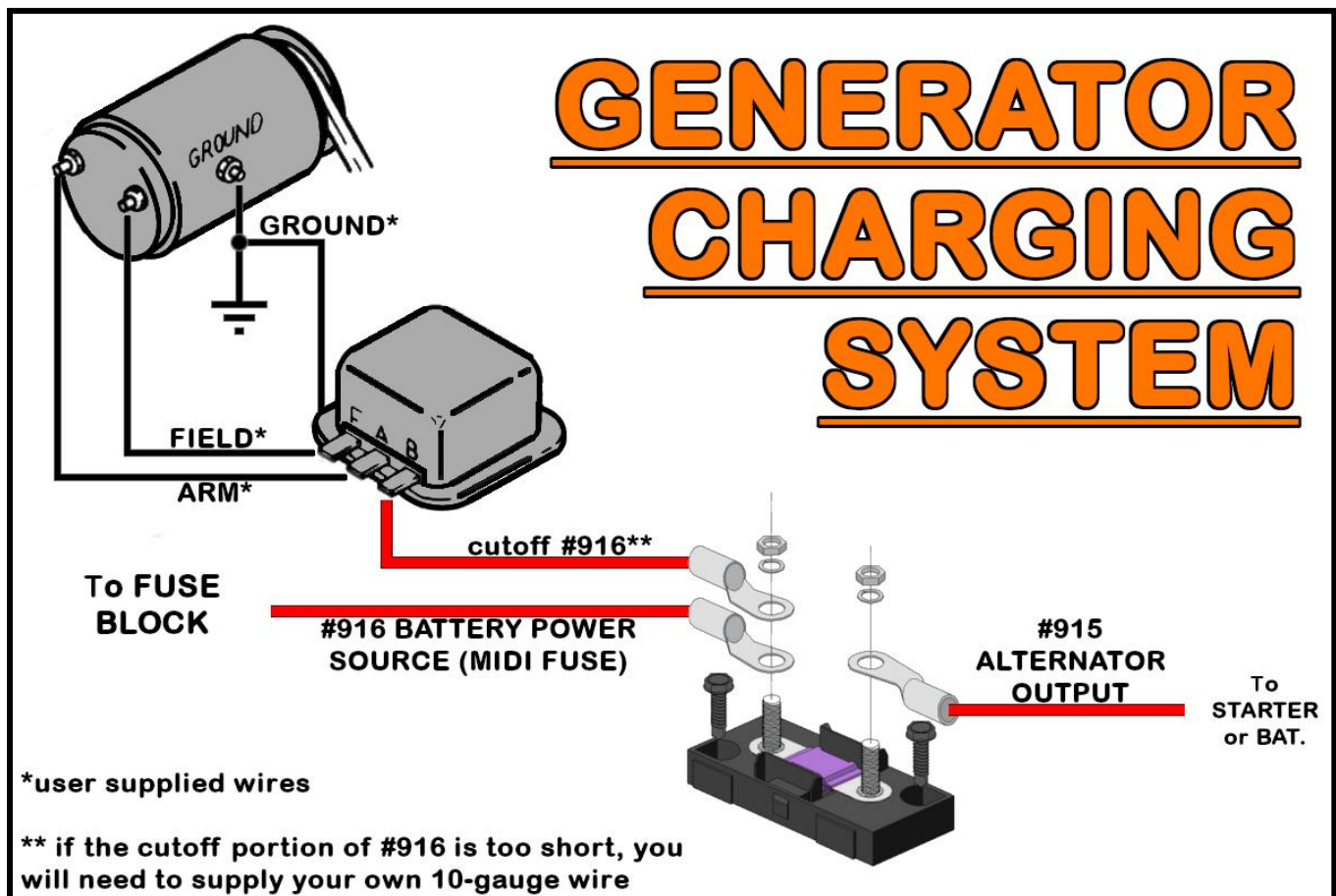

FORD EXTERNALLY REGULATED ALTERNATORS

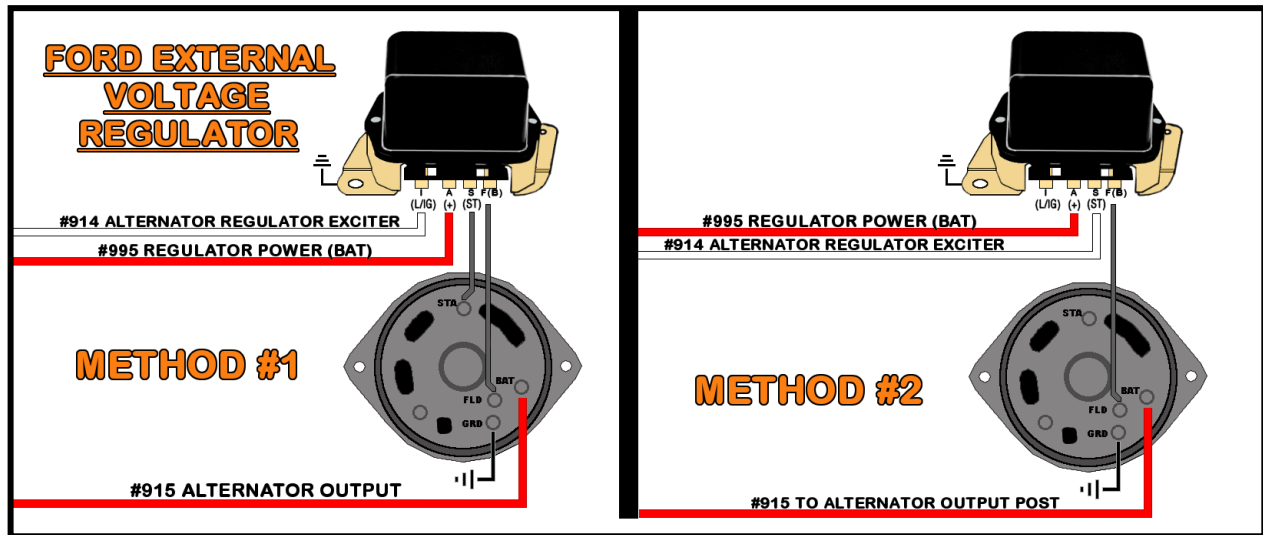

Note: Your Alternator may not appear exactly as represented above. However, the circuits are wired in the same manner.

The two remaining wires, a 14-gauge **RED** wire printed **#995 REGULATOR BATTERY POWER** and a 16-gauge **WHITE** wire labeled **#914 ALTERNATOR EXCITER**, will connect to the regulator.

- Route the two wires of the Painless harness to the connection point on the regulator and cut to length. Strip $\frac{1}{4}$ " of insulation from both wires.
- The 4-pin regulator connector from a factory harness will need to be used. Due to a lack of usage by most customers, these connectors are not included with this Painless chassis harness. If you do not have these connectors they can be obtained online, at a local auto parts store, or you can use the loose piece insulated terminals in the parts kit to make connections.

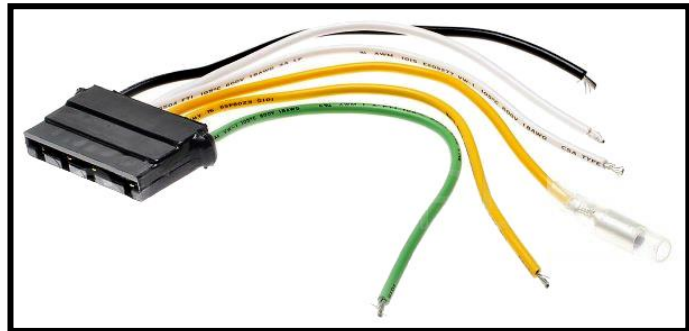

- The two methods to power the regulator depicted in the diagrams above are explained on the next page. The difference in the diagrams is where the **#914** wire connects, which in turn, will decide how many wires run from the regulator to the alternator. **Please be advised that a charge indicator light will only work if the regulator is wired according to Method 1.**

Method #1:

- Connect **RED #995** to the Voltage Regulator “A” terminal.
- Connect **WHITE #914** wire to the Voltage Regulator “I” terminal.
- Connect a 14-gauge wire from the Voltage Regulator “S” terminal to the Alternator Stator (S) terminal.
- Connect a 14-gauge wire from the Voltage Regulator “F” terminal to the Alternator Field (F) terminal.
- The Alternator case must be clean, and free from corrosion where it contacts the block. An additional connection from the ground stud on the rear of the alternator to the engine ground is highly recommended.

Method #2: An alternate (and less-used) method is to omit the Alternator Stator wire:

- Connect **RED #995** to the Voltage Regulator “A” terminal.
- Connect **WHITE #914** wire to the Voltage Regulator “S” terminal. Since the **#914** is on the “S” terminal of the regulator, the “S” or stator post on the alternator will not be connected.
- Connect a 14-gauge wire from the Voltage Regulator “F” terminal to the Alternator Field (F) terminal.
- The Voltage Regulator Ignition (I) terminal is not connected.
- The Alternator case must be clean, and free from corrosion where it contacts the block. An additional connection from the ground stud on the rear of the alternator to the engine ground is highly recommended.

NOTE: The base of the Voltage Regulator **MUST** be grounded for it to function correctly.

FORD 3G ALTERNATOR

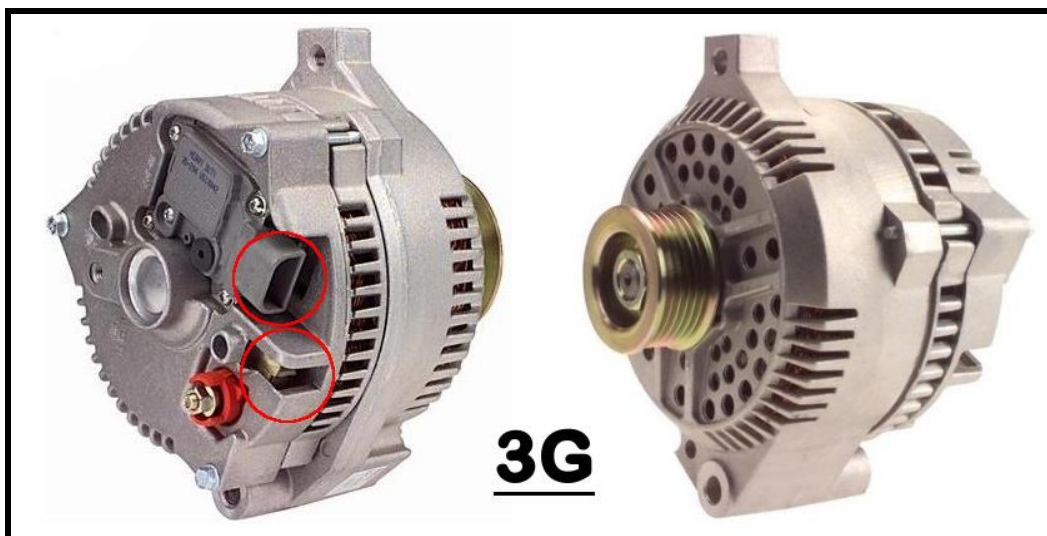

The two wires **RED** #995 ALT. REGULATOR POWER (BATTERY) and **WHITE** #914 ALTERNATOR REGULATOR EXCITER, connect to the pigtails on the back of the alternator.

There are 2 connectors from the factory Ford harness that need to be used: A D-shaped 3-pin connector and a single-pin connector (circled in the image above). Also, the installer will need to supply an inline fuse with a rating of 125 amps or more for this alternator. Due to a lack of usage by most customers, these connectors and this fuse are not included with this Painless chassis harness.



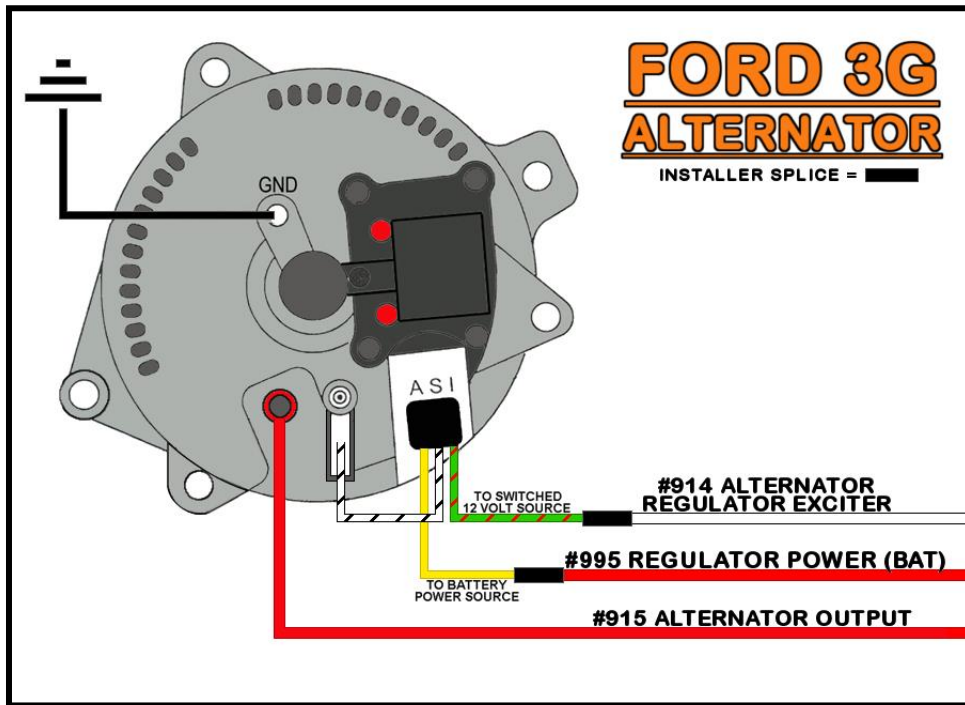

- The 3G alternator requires a switched power source to pin I of the regulator, this will be the #914 wire. Route the **WHITE** #914 to the **LT. GRN/RED** wire of the “I” terminal on the regulator pigtail and cut to length. Strip 1/4” of insulation.
- Route the **RED** #995 to the **YLW** wire of the “A” Terminal on the regulator pigtail and cut to length. Strip 1/4” of insulation.
- The 3G alternator requires a constant battery power source to pin A of the regulator, this will be the #995 wire. Using a splice and heat shrink provided, splice the 3G harness to the **WHITE** #914 & **RED** #995 wires according to the diagram above.

The 2G and 4G alternators wire up in the same manner as the 3G in regards to the “I” and “A” terminals on the regulator.

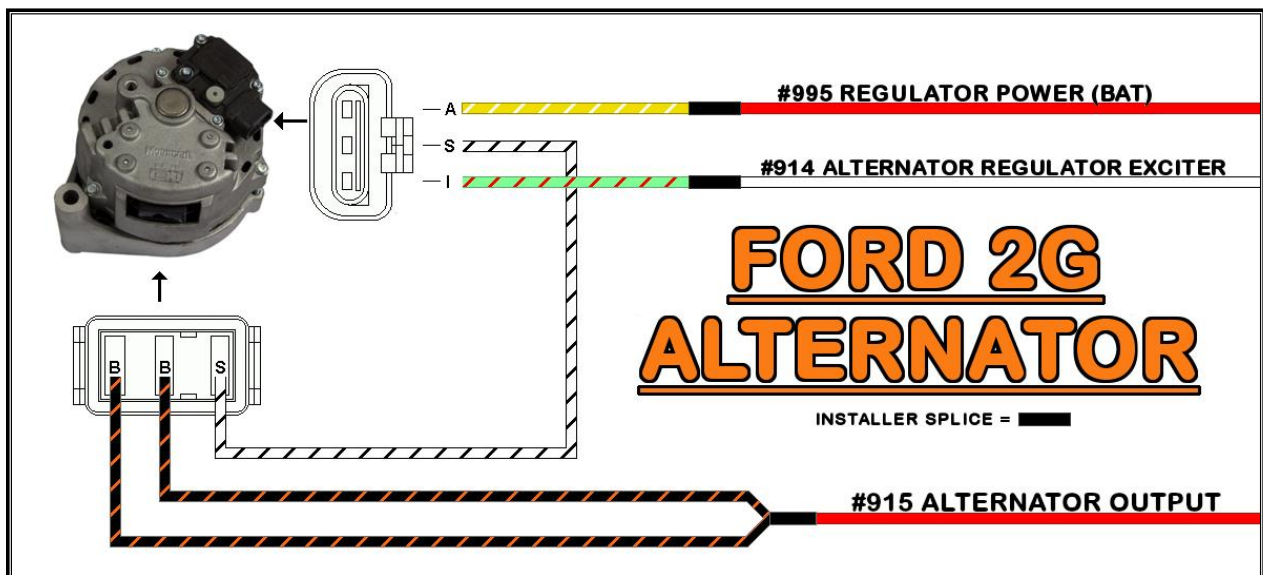

MOPAR EXTERNALLY REGULATED ALTERNATOR

Mopar uses one of two kinds of voltage regulators: An electronic regulator and a mechanical one. In both applications, the **RED #995** is not needed and can be removed from the harness or attached to the alternator output post.

Mechanical Regulator

The mechanical regulators, pre-1970, will have two posts marked "IGN" and "FLD". One post will exit one side of the regulator, while the other post will exit the other side. This regulator will use an alternator that has a single field terminal, as shown below.

- The **WHT #914** wire is connected to the "IGN" terminal of the regulator.
- The "FLD" terminal of the regulator is connected to the field terminal of the alternator. The **#914** wire left from the first connection should have sufficient length for this.

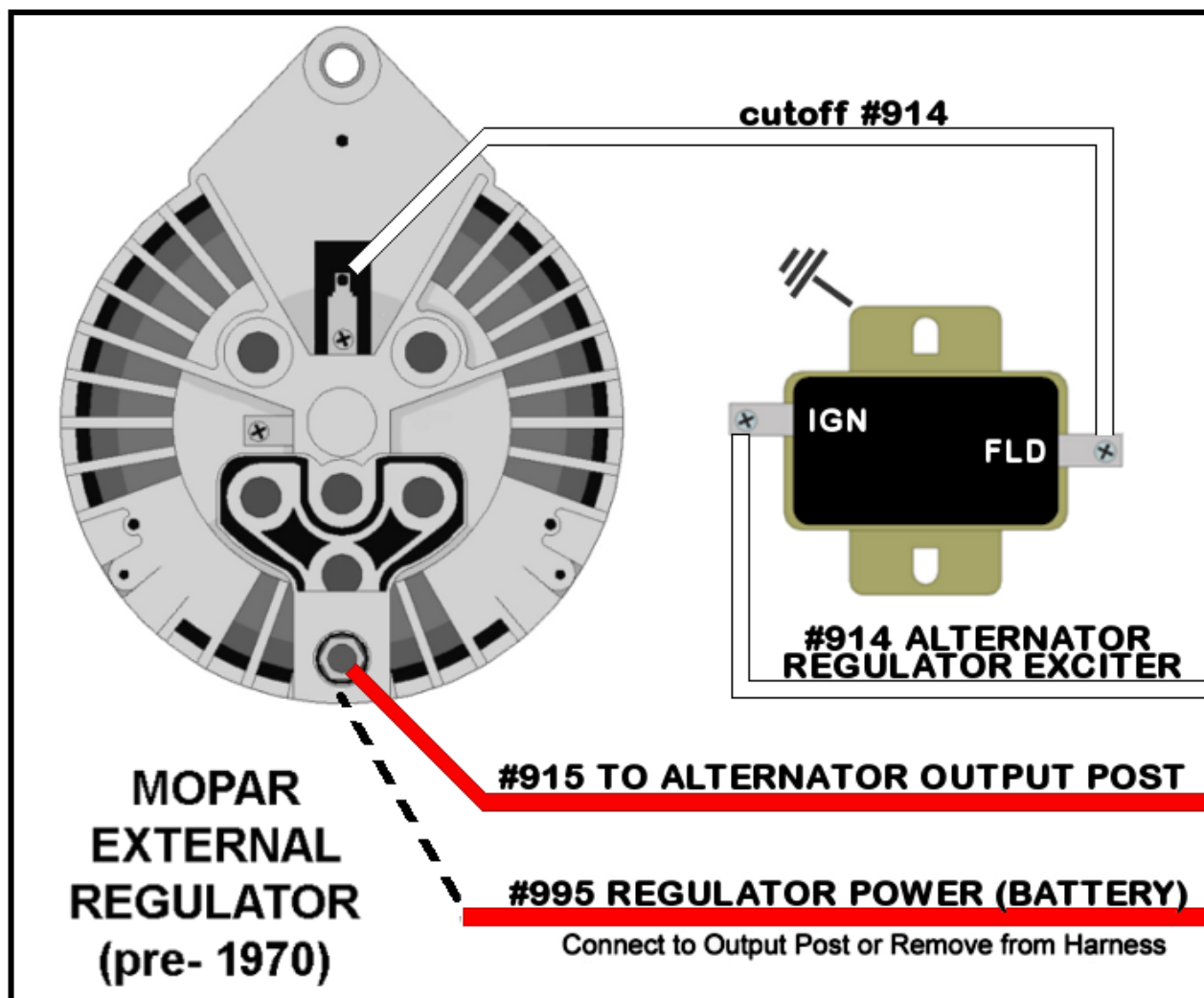

Electrical Regulator

The electrical regulators, 1970+, will also have two posts marked "IGN" and "FLD", but both posts will be found on top of the regulator and will require a connector. This regulator will use an alternator that has two field terminals, as shown in the diagram above.



The factory, 2-wire regulator connector from the harness needs to be used. Due to a lack of usage by most customers, these connectors are not included with this Painless chassis harness. If you do not have these connectors, they can be obtained online, at a local auto parts store.

- Plug the connector into the voltage regulator.
- Then, route the **WHT #914** wire to the **BLUE** factory wire running from the "IGN" terminal on the regulator connector. Cut to length and strip $\frac{1}{4}$ " of insulation.
- Splice the **BLUE** factory wire and the **WHT #914** wire together with the cutoff portion of the **#914** wire using a butt-splice and heat shrink from the parts kit (see image above).
- Then, route the **WHT #914** wire to one of the "FLD" tabs of the alternator. Cut to length, strip $\frac{1}{4}$ " of insulation, and connect using an insulated spade terminal from the parts kit.
- Route the **GRN** factory wire from the regulator connector to the other "FLD" tab of the alternator and connect.

Finally, make sure **BOTH** the alternator and the voltage regulator housing are grounded.

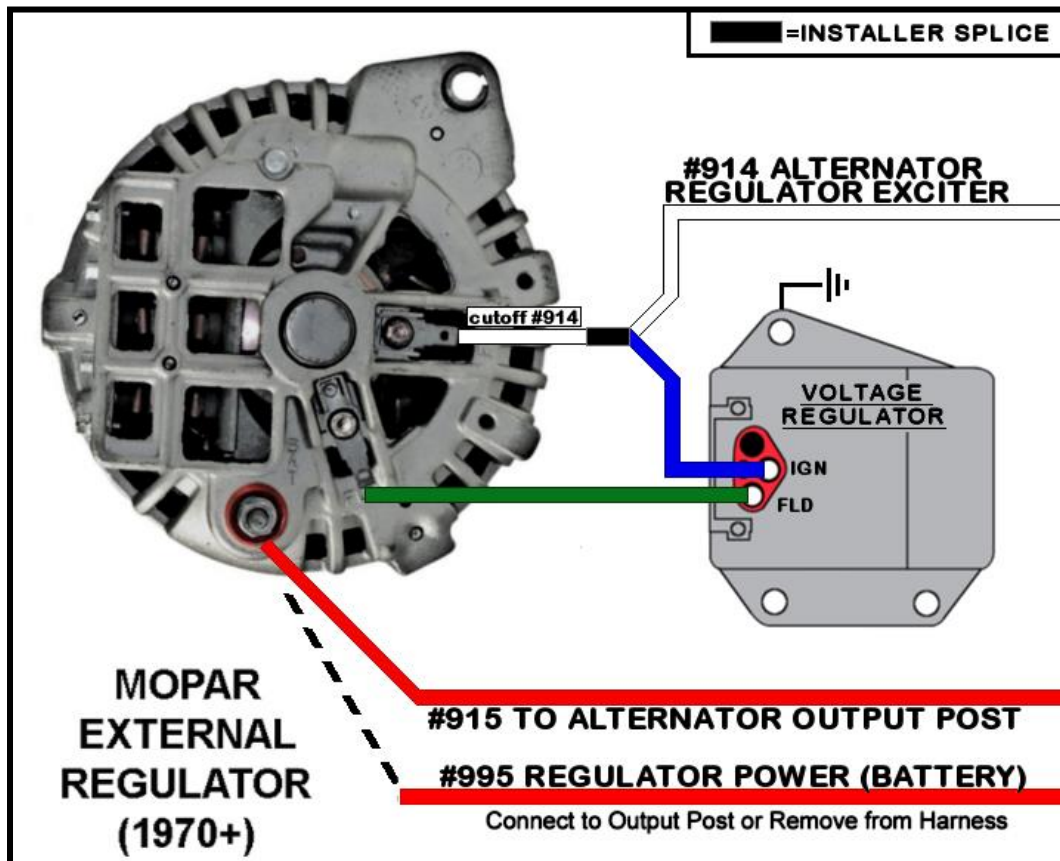

MIDI FUSE

A large, inline MIDI fuse is included in the “ALTERNATOR” bag kit. This inline fuse provides a fused link between the alternator and battery.

- Find a suitable location to mount the supplied fuse holder using the **(2) self-tapping screws** provided. A drill with a **¼” nut driver** is required to drill holes for the mounting screws.

With the fuse holder now mounted, locate the following two wires:

RED: 10-gauge wire, printed **#916 BATTERY POWER SOURCE (MIDI FUSE)**; all power sources in this Painless harness originate from this wire. This wire provides battery power to the fuse block, which in turn supplies battery power to the ignition switch, which provides switched power. During normal operation, this wire always has constant battery power.

RED: 6-gauge wire, rolled separate from the harness, with a tag reading **#915 ALTERNATOR OUTPUT**; this wire provides power from the alternator to the battery through the MIDI fuse. See [Charge / Battery Power Schematic](#) on [page 48](#). The other end of this wire connects to the output post of the alternator.

- Route the **#915** and **#916** wires to one side of the fuse holder and cut the wires to length. **DO NOT DISCARD THE CUT OFF PORTION OF #915.**

The length of excess wire cut from the **#915** wire will be used to connect the other side of the fuse to the “+” side of the vehicle’s battery or to the battery post on the starter solenoid. **DO NOT CONNECT THE #915 TO THE ACTUAL BATTERY AT THIS TIME.** If routed to the starter solenoid, this wire will NOT replace the battery cable needed by the starter from the positive side of the battery to the “BAT” or (+) post of the starter solenoid.

- Make connections to both sides of the fuse holder with the large ring terminals with the small, **#10 hole** provided with the kit. You can use a pair of pliers if your crimpers will not accept this large gauge wire/terminal. The heat-shrink supplied with this kit is intended to cover the crimped end of each of these (2) ring terminals. A schematic showing these connections can be found on [page 48](#).
- Once you install the ring terminals onto both studs of the fuse holder, the fuse can be installed, and everything can be tightened down with the two retaining nuts provided with the fuse holder. Once everything is tightened, the cover can be reinstalled. Depending on how your crimp flares the ring terminal, the cover may or may not need slight trimming to snap into place.

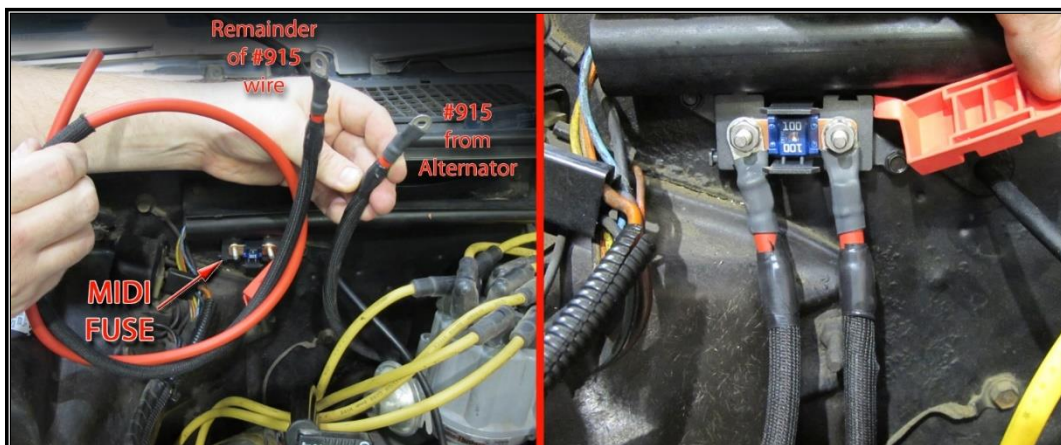

STARTER SOLENOID

The connections to the starter solenoid vary depending on your ignition system, the location of a neutral safety/clutch switch, and your connection point on the battery power source for the MIDI fuse.

One connection to the starter solenoid all vehicles share is power from the ignition switch. However, how we get to this connection will vary based on the harness and where the neutral safety switch is located.

10201 & 10203

PURPLE: 12-gauge wire, printed << [ENGINE SECTION] TO STARTER SOLENOID << #919 >> [NEUTRAL SAFETY SWITCH] >>; this wire will supply the solenoid with a switched power source from the ignition switch. This power will activate the starter solenoid causing it to turn the engine over for startup. This wire will only have power when the ignition switch is in the *Start/Crank* position.

Note: This wire originates at the interior neutral safety switch. **If you are using a transmission mounted NSS**, this wire should have been connected to the other **PURPLE #919** wire coming from the **Ignition Switch Section** on **page 92**. This wire must then be routed to the NSS and cut to length. Finally, the cut-off portion will be routed to the starter solenoid from the transmission mounted NSS.

- Route the **PURPLE #919** and the ballast bypass, if needed, to the starter solenoid and cut to length. If the remainder of **#916** from the MIDI fuse is being connected to the “BAT” or (+) post of the starter solenoid, it may be routed at this point as well. Be sure to keep all wires away from the exhaust manifold or header.
- Locate the ring terminal and heat shrink from the parts kit that best fits the posts found on the starter solenoid and install onto the wires going to the starter solenoid. Be sure to apply heat shrink the insulation to protect the crimp.
- The **PURPLE #919** wire will connect to the “START” or “S” post on the solenoid and the bypass wire, if needed, will connect to the “I” or “R” post of the solenoid.
- If you are connecting the battery supply to the MIDI fuse to the battery cable/post on the starter, connect it now. **BE SURE THE BATTERY CABLE IS DISCONNECTED FROM THE BATTERY BEFORE MAKING THIS CONNECTION.**

10202 & 10204

PURPLE: 12-gauge wire, printed << [ENGINE SECTION] TO STARTER SOLENOID << #919 >> [IGNITION SWITCH] >>; this wire will supply the solenoid with a switched power source from the ignition switch. This power will activate the starter solenoid causing it to turn the engine over for startup. This wire will only have power when the ignition switch is in the *Start/Crank* position.

Note: This wire may not be in the engine compartment at this time. This wire will need to be routed, cut to length, and connected to one side of the neutral safety or clutch switch. The cut-off portion of #919 will then connect to the other side of the neutral safety or clutch switch and then be routed to the starter.

- Route the **PURPLE #919** and the ballast bypass, if needed, to the starter solenoid and cut to length. If the remainder of #916 from the MIDI fuse is being connected to the “BAT” or (+) post of the starter solenoid, it may be routed at this point as well. Be sure to keep all wires away from the exhaust manifold or header.
- Locate a ring terminal and heat-shrink from the parts kit that best fits the posts found on the starter solenoid and install onto the wires going to the starter solenoid. Be sure to apply heat-shrink the insulation to protect the crimp.
- The **PURPLE #919** wire will connect to the “START” or “S” post on the solenoid and the bypass wire, if needed, will connect to the “I” or “R” post of the solenoid.
- If you are connecting the battery supply to the MIDI fuse to the battery cable/post on the Starter, connect it now. **BE SURE THE BATTERY CABLE IS DISCONNECTED FROM THE BATTERY BEFORE MAKING THIS CONNECTION.**

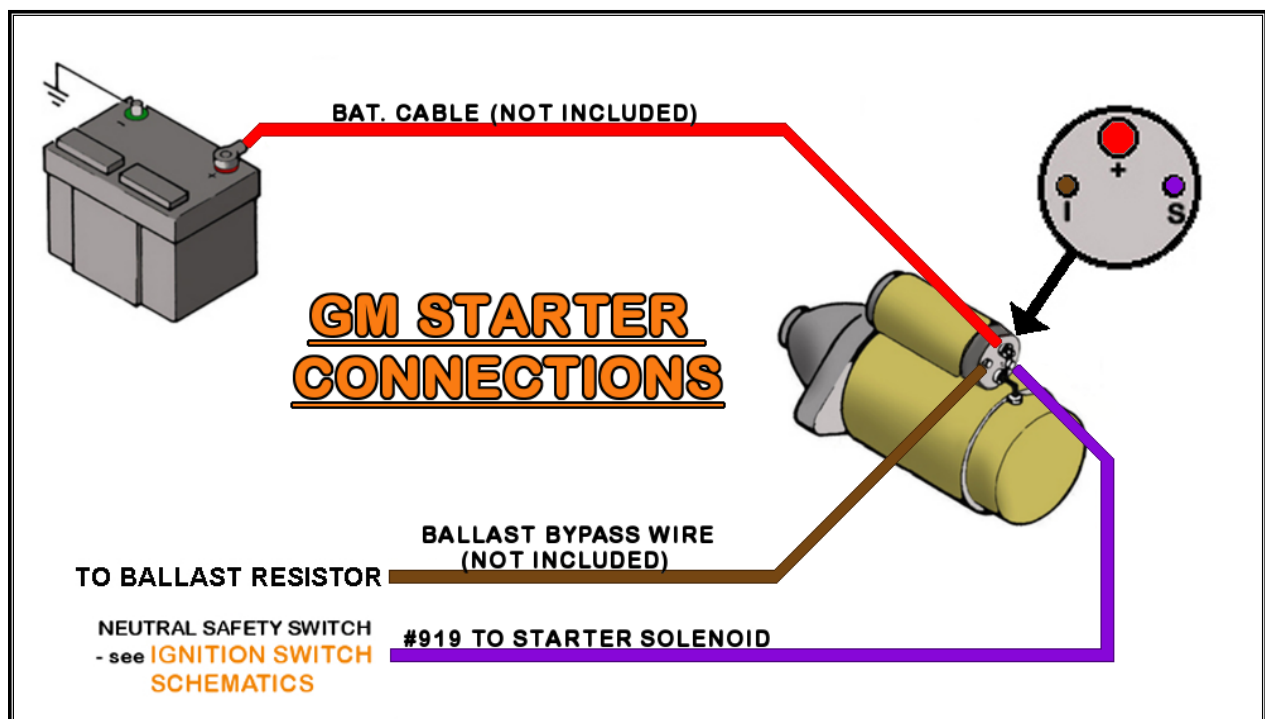

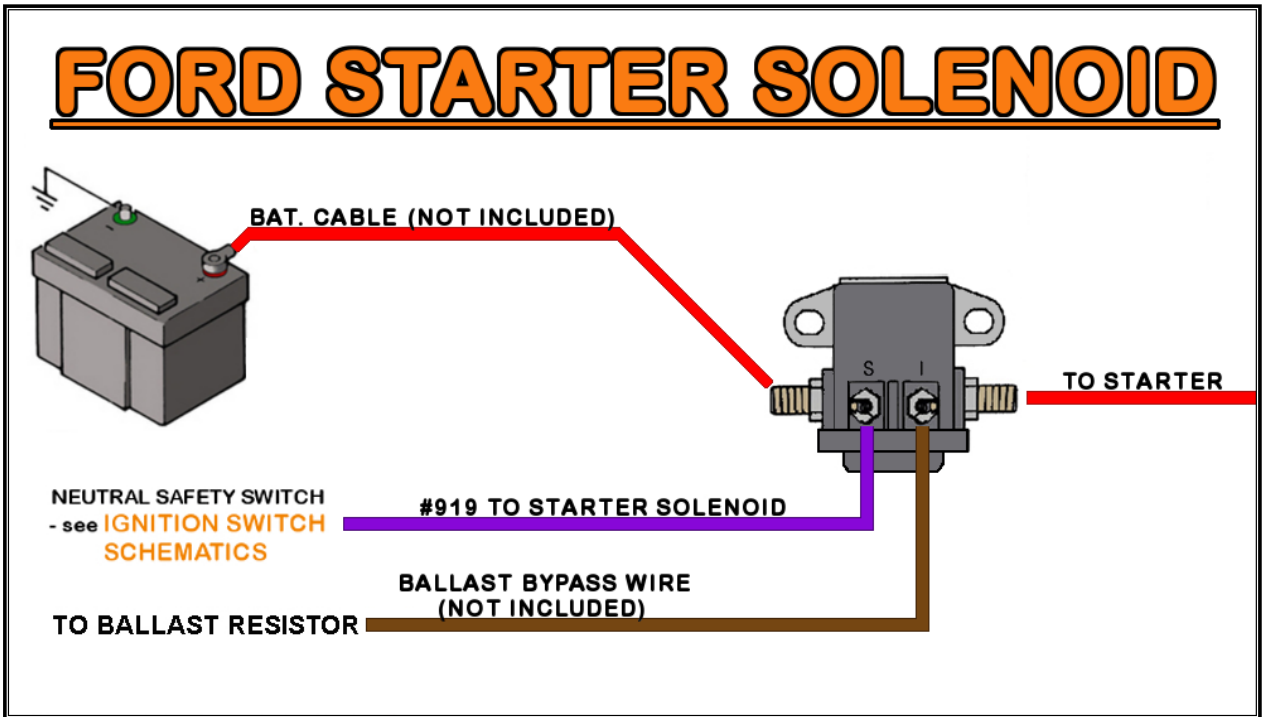
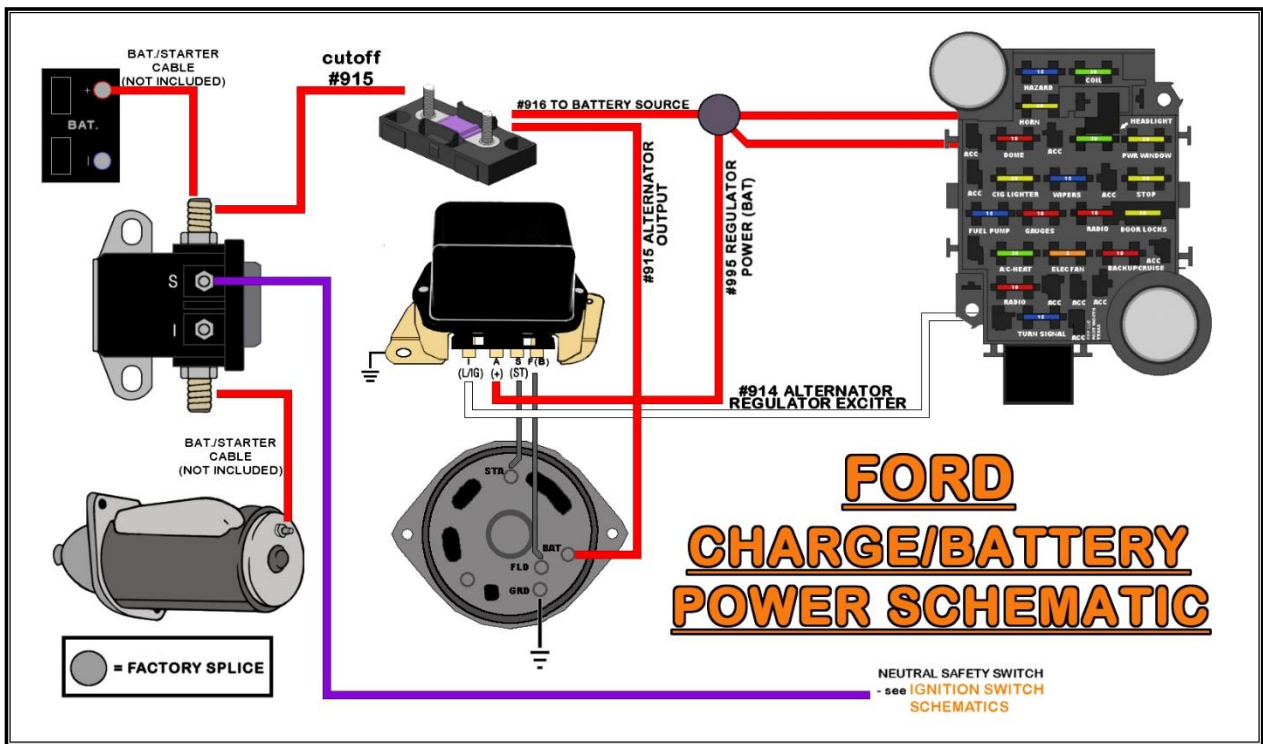

Mopar Starter Relays

Use the following instructions and diagrams if you are wiring in a Mopar starter relay. Please be aware that if a ballast resistor is being used, you will need a relay with a ballast terminal. Locate heat shrink and ring terminals from the parts kit that best fit the posts/terminals found on the starter relay, crimp and connect.

- Connect the **PURPLE #919** wire to the Starter Relay Ignition (I) terminal. This will activate the relay when 12v is applied when the key is in the “START” position.
- Connect a 14-gauge wire (not supplied) from the Starter Relay Ground (G) terminal to the center terminal of the transmission mounted Neutral Safety Switch.
 - Older Mopar neutral safety switches have only one terminal. On newer switches, the two outside terminals are for backup lights. Use existing wiring to connect these two terminals as shown in the diagram below.
- If using a harness with the GM column connectors, but using the Mopar Neutral Safety Switch, or neutral safety switch on a floor shifter, you will need to splice together the **PURPLE** wires at the steering column wiring.
- If the Neutral Safety Switch is mounted in the floor shifter, connect the Starter Relay Ground (G) terminal to chassis ground.

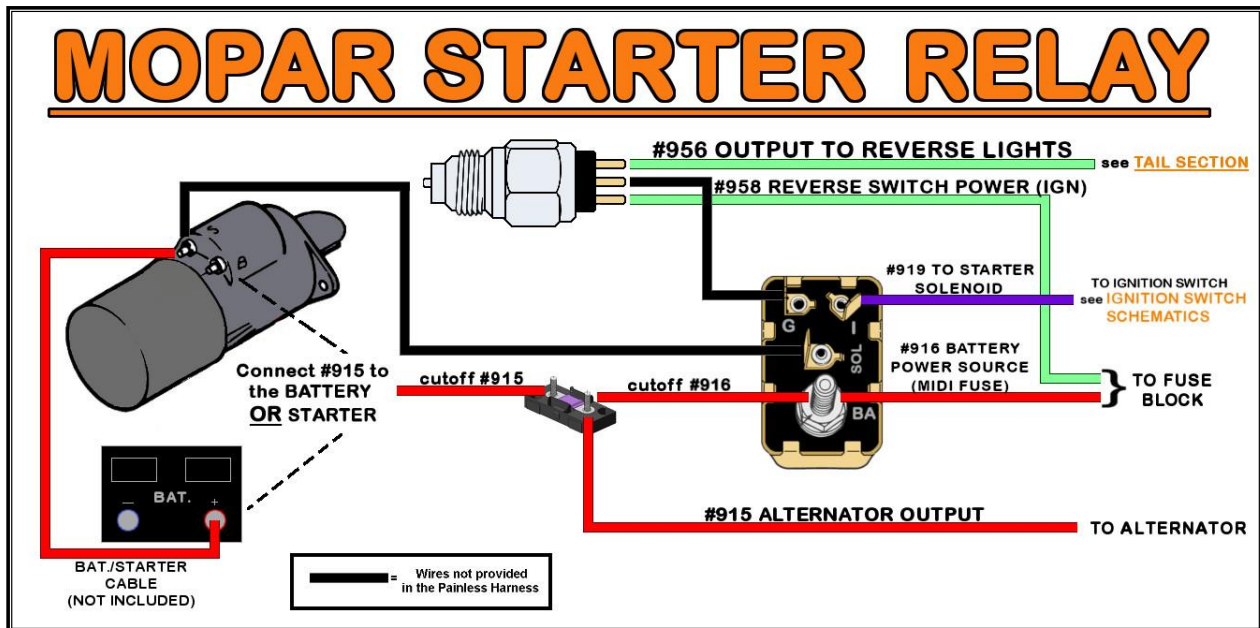

- Connect the “BAT” post on the relay to a battery power source. This is easily done by connecting this post to the output/harness side of the MIDI fuse, inline on the **#916** wire as shown in the diagrams above and on the following page. This post provides the power that is transferred through the relay, to the starter.
 - Those without a Mopar reverse switch/neutral safety switch, connect the “G” terminal to a clean chassis ground source using a cut off piece of 16- or 18-gauge wire from a previous connection, as shown in the [SR14 Relay](#) diagram on the next page.

- The terminal on the relay marked “SOL” will need to have a wire that runs from this terminal to the “S” post on the starter. This terminal on the relay provides power to the starter solenoid. The Painless harness does not have a wire dedicated for this connection, but a 12- or 14gauge scrap wire cut from another connection of this harness will work.

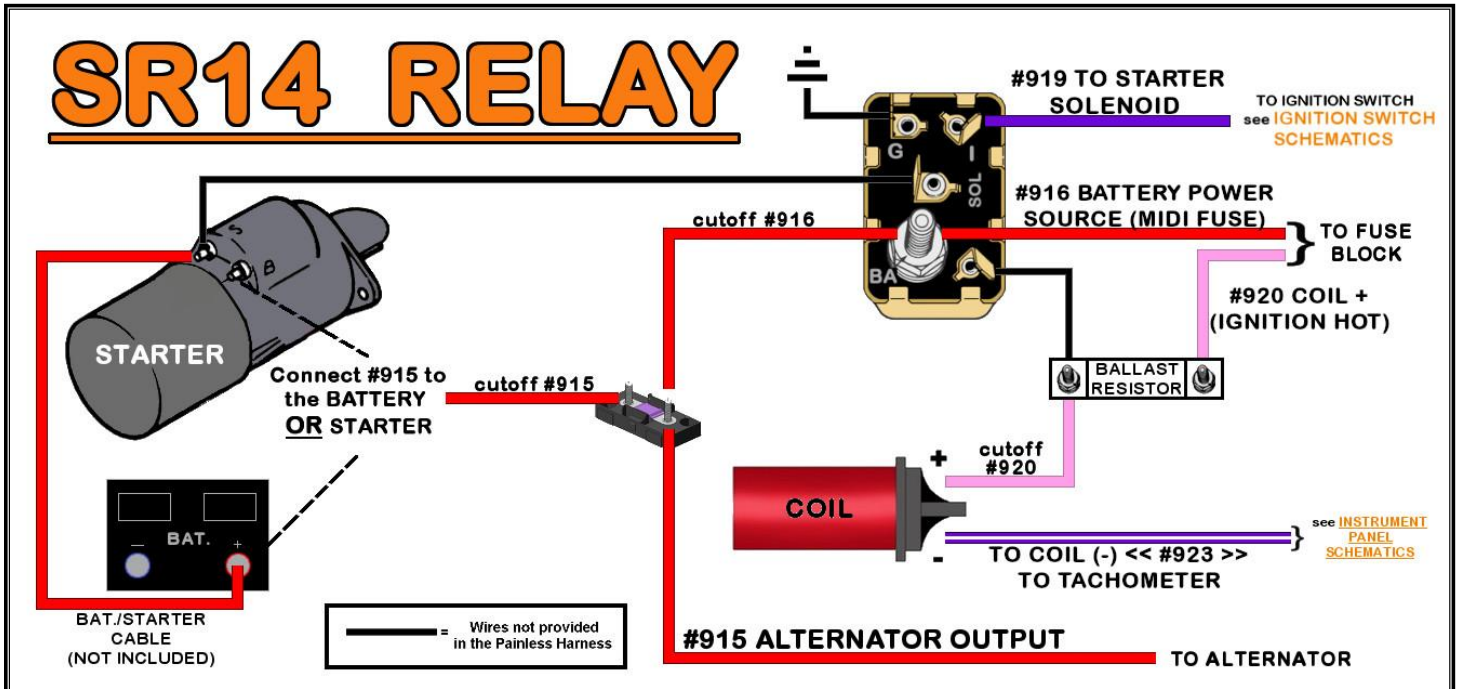

- If you are using an SR14 Relay and a ballast resistor, connect the **PNK #920** wire to one end of the Ballast Resistor.
- Then, connect the other end of the ballast resistor to the ignition coil POSITIVE (+) terminal with 14-gauge wire (you may have enough **PNK #920** wire left over to accomplish this). Then run a 14-gauge wire (not supplied) to the “BAL” terminal on the Starter Relay

NOTES:

INTERIOR HARNESS

Now that the Engine Sections are wired, move to the interior of the vehicle.

Before you make any connections on the inside of the vehicle, let us address the component switches: like the headlight switch, brake switch, turn signal switch, ignition switch, and headlight dimmer switch.

With older vehicles and hot rods in general, many times switches are replaced by what is available or what previous owners had lying around. In some cases, these switches are not marked and there is no idea what pins on the switch controls each function. If you are unsure about the positions or functionality of the switches currently in your vehicle and are not up to the task of figuring out what each pin does, Painless offers several solutions. We have switch kits and sell switches individually.

For those using a [10202](#) or [10204](#) harness, a common switch kit that many people choose is [Painless part #80121](#). This kit provides you with a new headlight switch, new dimmer switch, door jamb switches, and ignition switch, all marked with each terminal's function. Part numbers for individual switches are given in each individual section.



DIMMER SWITCH

The first connection is the group of three wires that belong to the **Dimmer Switch Section**. These three wires provide power to the headlights for low beam and high beam power. These wires can be seen in the [Headlight Dimmer Switch Schematic](#) on the next page. They are:

BLUE/YELLOW: 14-gauge wire, printed << [DIMMER SWITCH] << #907 >> DIMMER SWITCH POWER [HEADLIGHT SWITCH] >>; this wire provides power to the dimmer switch from the headlight switch. This wire has power whenever the headlight switch is in the “HEADLIGHT ON” position.

TAN: 14-gauge wire, printed [DIMMER SWITCH] #909 LOW BEAM; this wire provides power from the dimmer switch and into a splice with 2 other wires. The other two wires feed power to each low beam of the headlights, as seen in the [Front Light Section Schematic](#) on [page 36](#). Once connected, this wire has power when the headlight switch is in the “HEADLIGHT ON” position and the dimmer switch is in the “LOW BEAM” position.

LT. GREEN: 14-gauge wire, printed [DIMMER SWITCH] #908 HIGH BEAM; this wire provides power from the dimmer switch and into a splice with 3 other wires. The other wires feed power to each high beam of the headlights and the high beam indicator as seen in the [Front Light Section Schematic](#) on [page 36](#). Once connected, this wire has power when the headlight switch is in the “HEADLIGHT ON” position and the dimmer switch is in the “HIGH BEAM” position.

The connection point of these wires depends on the location of the dimmer switch. Most have a floor-mounted dimmer switch, although, those using a later model GM column may find the dimmer switch on the side of the column.

- Route all 3 wires to the dimmer switch and cut to length.
- Connect the three wires to the dimmer switch as shown in the diagram on the next page.



For those using a GM style switch, either column or a floor-mounted like [Painless part #80150](#), a connector and terminals have been provided. **Note:** this connector comes pre-installed on kit #'s [10201 & 10203](#).

HEADLIGHT DIMMER SWITCHES

GM COLUMN MOUNTED

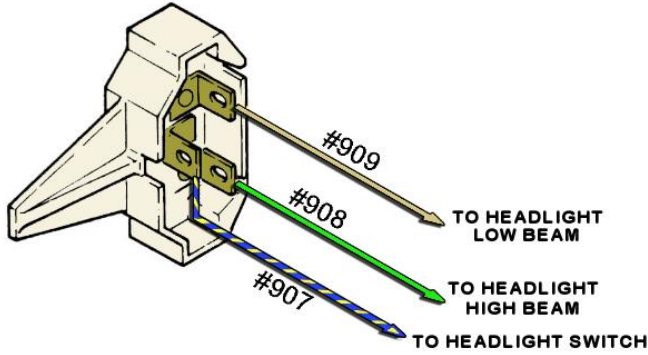

GM FLOOR MOUNTED

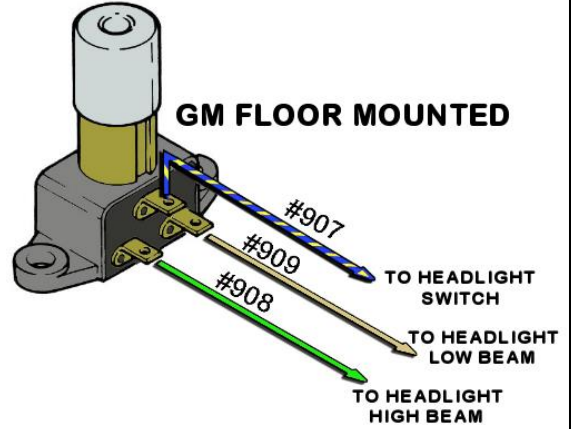

FORD HEADLIGHT DIMMER SWITCH

#907 DIMMER SWITCH POWER

#908 HIGH BEAM

#909 LOW BEAM

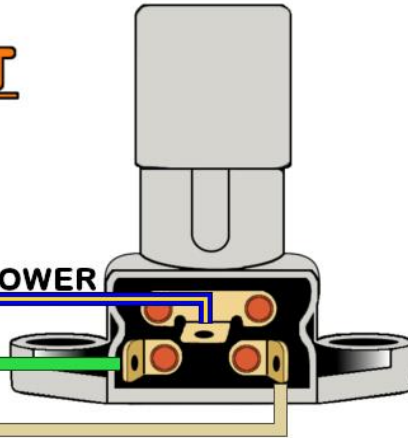

SPlicing TO FORD PIGTAIL

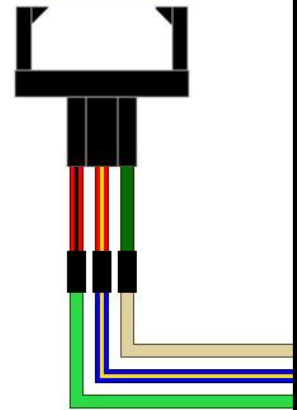

HEADLIGHT SWITCH

The headlight switch's connections send power to the headlights, front park/marker lights, rear taillights, and component backlighting, such as gauges and the radio. These wires can be seen in the [Headlight Switch & Dimmer Switch Schematic](#) on the next page. These seven wires are:

ORANGE: 14-gauge wire, printed **[HEADLIGHT SWITCH] #959 HEADLIGHT SWITCH POWER (BAT)**; this wire supplies constant battery power for the park/taillights as well as for the gauge backlighting. This wire comes from the 20-amp HORN fuse on the fuse block.

BROWN: 18-gauge wire, printed **[HEADLIGHT SWITCH] #927 FRONT PARK LIGHTS**; this wire supplies power to the park lights. This wire has constant battery power any time the headlight switch knob is pulled to Park Light ON and, depending on your switch, the Headlight ON position.

BROWN: 14-gauge wire, printed **[HEADLIGHT SWITCH] #929 TAILLIGHTS**; this wire supplies power to the taillights. This wire has constant battery power any time the headlight switch knob is pulled to both the park light ON and headlight ON positions.

BROWN: 18-gauge wire, printed **#930 INSTRUMENT PANEL LIGHTING**; this wire provides power to the gauge lights. This wire should have constant battery power any time the headlight switch knob is pulled to both the park light ON and headlight ON positions.

BLUE/YELLOW: 14-gauge wire, printed **<< [DIMMER SWITCH] << #907 >> DIMMER SWITCH POWER [HEADLIGHT SWITCH] >>**; this wire supplies power to the dimmer switch for headlight operation. This wire has constant battery power any time the headlight switch knob is pulled to the headlight ON position.

RED/BLACK: 12-gauge wire, printed **[HEADLIGHT SWITCH] #928 HEADLIGHT SWITCH POWER (BAT)**; this wire provides constant battery power to the headlight switch for headlight operation. This wire comes from the 30-amp HEADLIGHT fuse on the fuse block.

BLACK: 18-gauge wire, printed **<< [TAIL SECTION] DOME LIGHT GROUND << #961 >> DOME/COURTESY LIGHT ACTIVATION [HEADLIGHT SWITCH] >>**; this wire provides a ground source for the interior dome/courtesy lights.

- Route the wires to the headlight switch and connect them. Reuse your factory connector or use the insulated terminals provided in the parts kit.

The use of some or all these wires will depend on the headlight switch you use. Factory style switches will use all wires, whereas most universal switches may not require all of them. Diagrams have been provided of the most common switches, along with universal switches that Painless also offers.

If your switch does not have a separate terminal for gauge backlighting, connect wire **#930** with the taillight wire **#929** at the switch. If your switch does not have separate tail and park terminals, **#927** and **#929** wires will connect at the switch. In the case you do not have a backlighting terminal and do not have separate tail/park terminals, all three wires **#930**, **#927**, and **#929** will all share the same terminal on the switch.

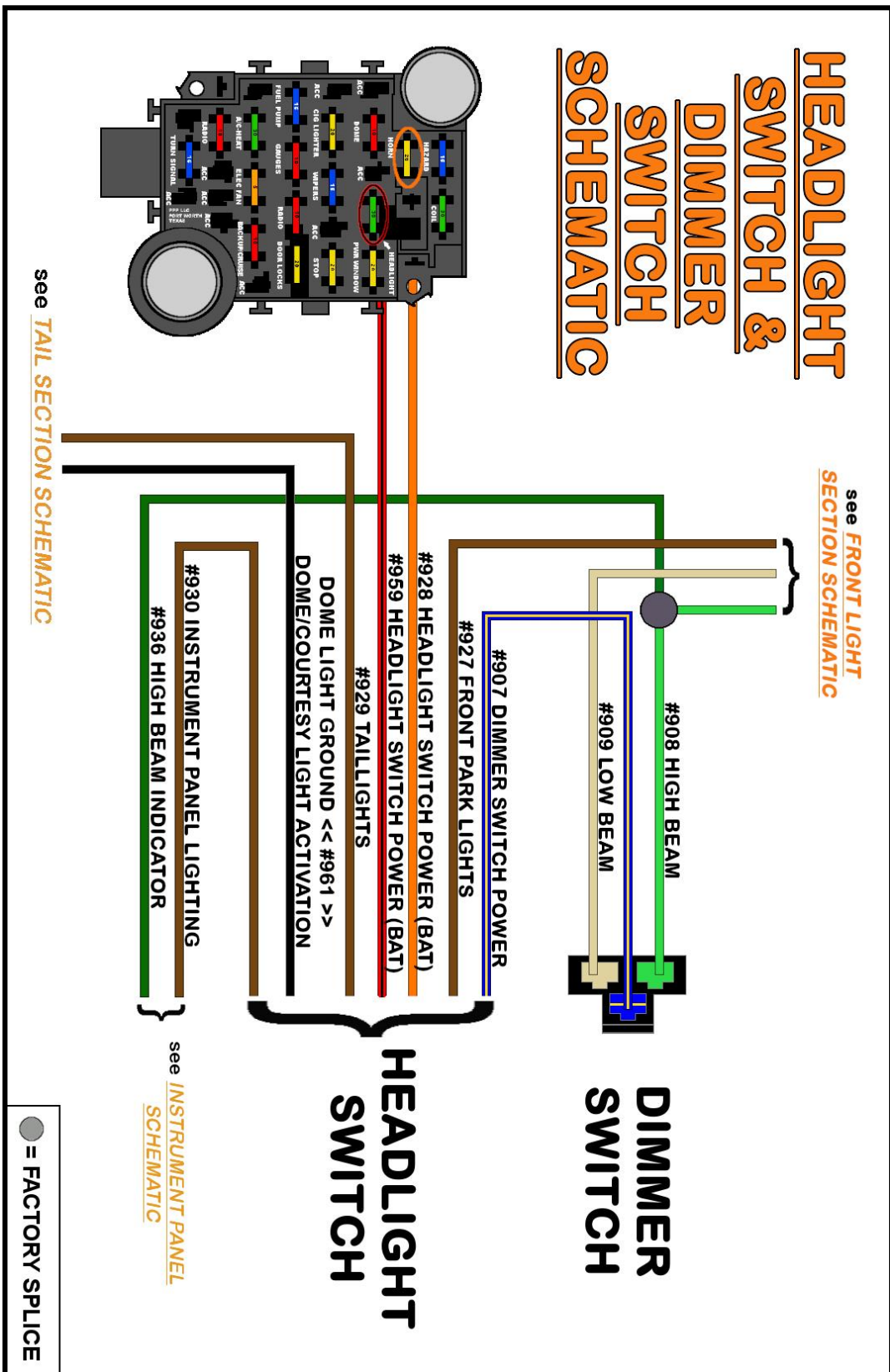

GM HEADLIGHT SWITCHES

Use the following diagrams to connect to a GM style headlight switch. GM used this style of headlight switch from the 1960s up through the 1980s. There are 2 different types of these switches, commonly referred to as early and late styles. The only difference is the tab to which the park lights connect (see the diagrams below for an illustration of this difference). Painless offers the early style switch with a headlight pull, [part #80152](#), seen in the photo to the right.

If you do not have a connector, use the light blue insulated terminals found in the parts kit to make these connections.

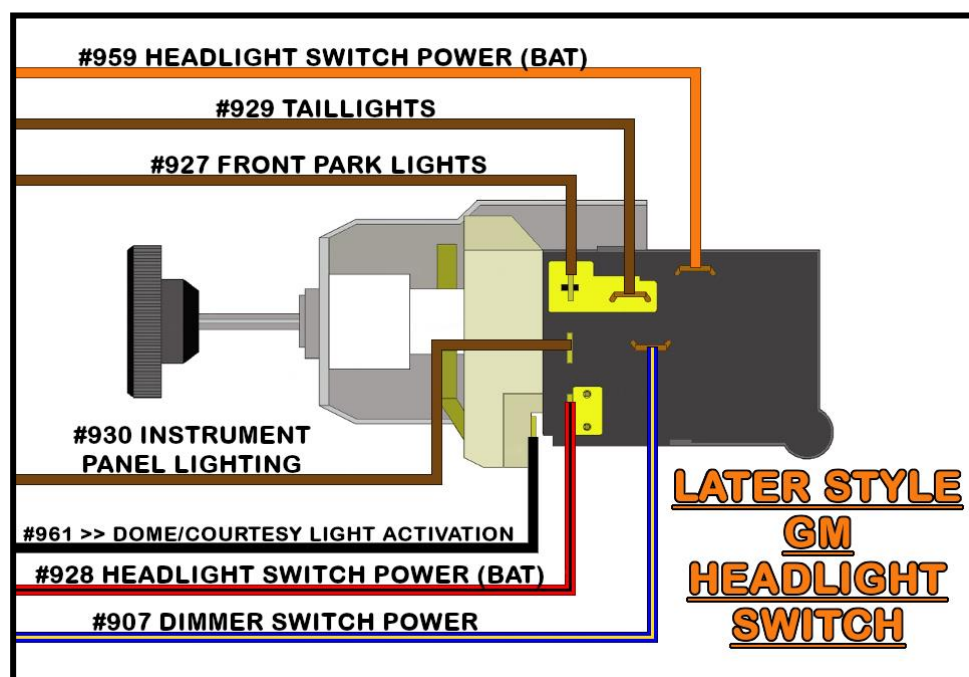
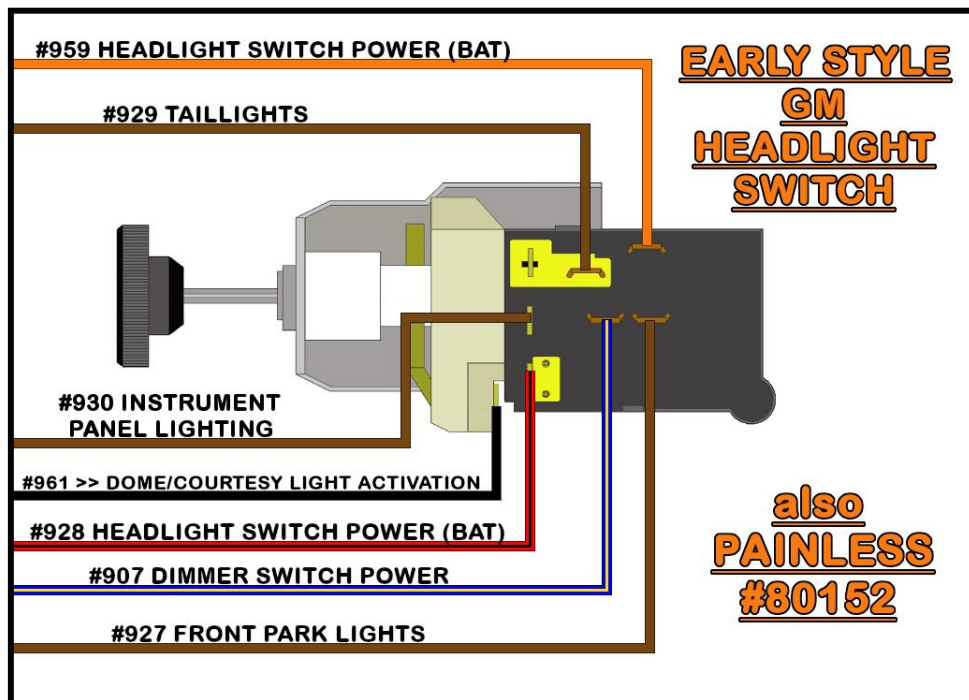

FORD HEADLIGHT SWITCH

Use the following diagram to connect to a Ford style headlight switch. This style switch was common on Ford vehicles used in the 1960s and 1970s. Use the insulated terminals found in the parts kit to make these connections.

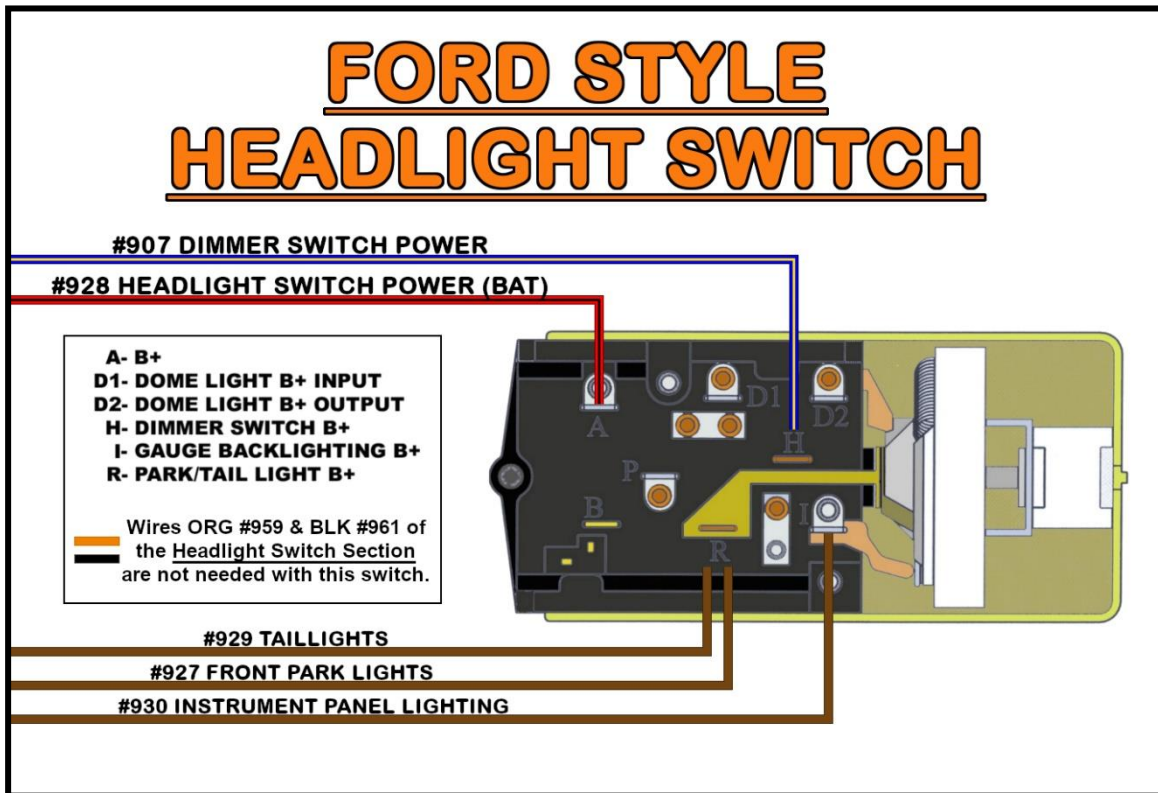

- The **BROWN #927** wire can be connected to the “P” terminal as well but doing so will cause the park lights to switch off when the headlights are on.
- The **RED/BLACK #928** wire can also be connected to the “B” terminal. However, connecting the #928 wire to the “A” terminal bypasses the internal circuit breaker, which was known to cause issues.

CHRYSLER HEADLIGHT SWITCH

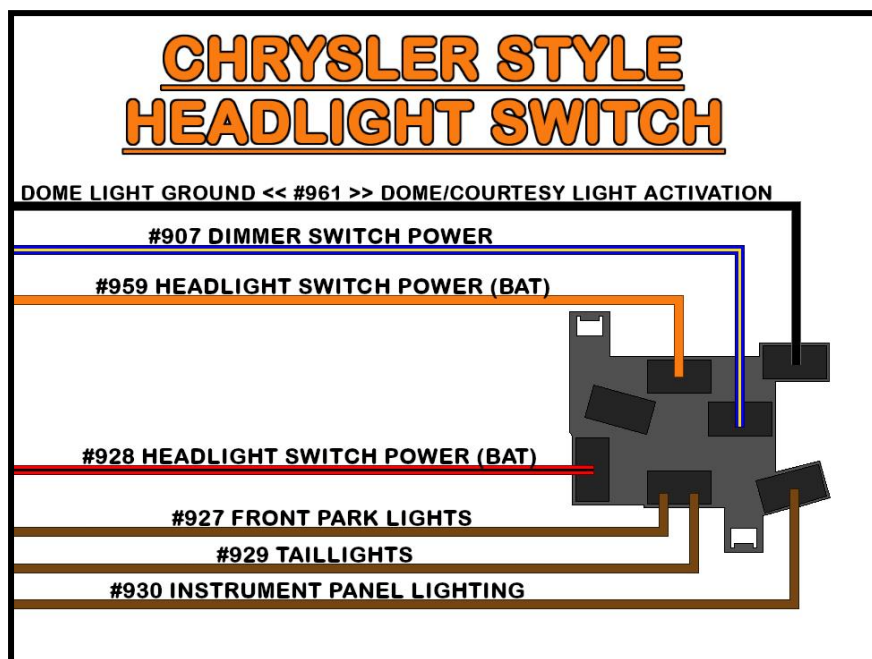

PAINLESS UNIVERSAL HEADLIGHT SWITCHES

Painless offers several universal switches as well, and even one with hi-low beam dimmer functions. Use the following diagrams to connect to either of the universal headlight switches offered by Painless. Use the blue insulated ring terminals found in the parts kit to make these connections.

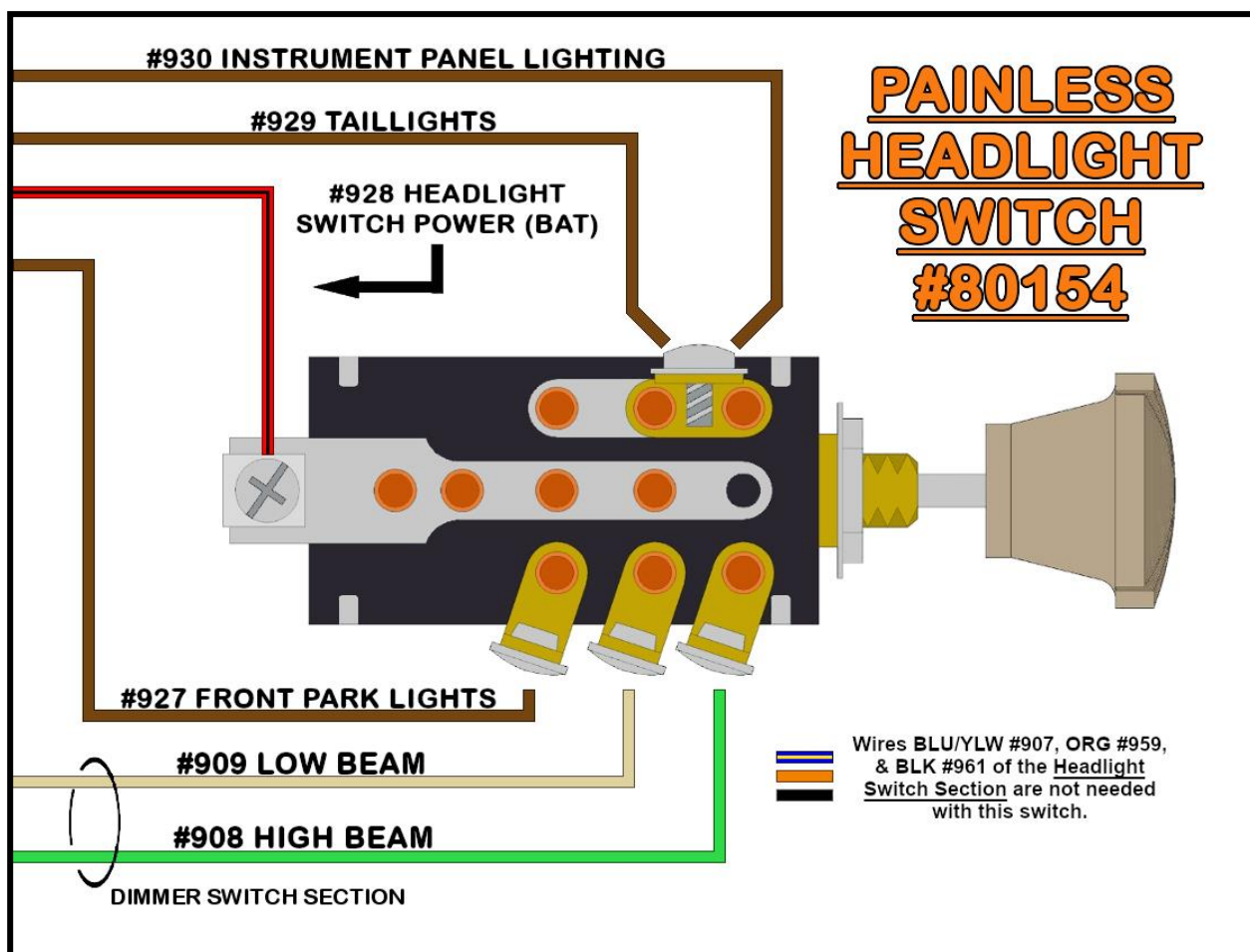
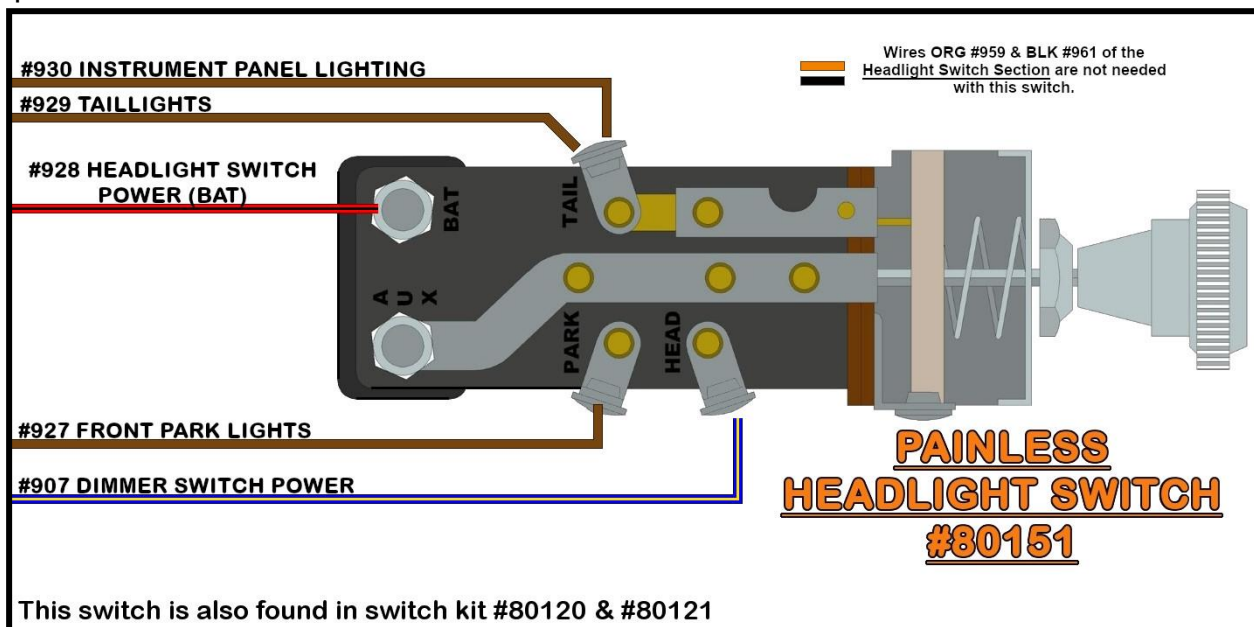

TOGGLE / ROCKER HEADLIGHT SWITCH

Some vehicles, such as T-buckets, and others that may have a smaller narrower dashboard, may not have the room or want the clutter of a bigger headlight switch. Reference the diagrams below to install a lighted or non-lighted SPST (Single Pole Single Throw) toggle or rocker switch. This will also require the use of 2 SPST relays.

The small black and red lines and seen in the diagrams are wires that need to be provided by the installer, these can be small 18-gauge wires since they are only providing ground/ power for relay activation and power for the backlighting of a switch.

The diode seen in the diagram is the same as the diode provided in the alternator bag kit. If you are not using the diode with your alternator it may be used for this purpose, if you need a diode, [Painless offers #30720](#).

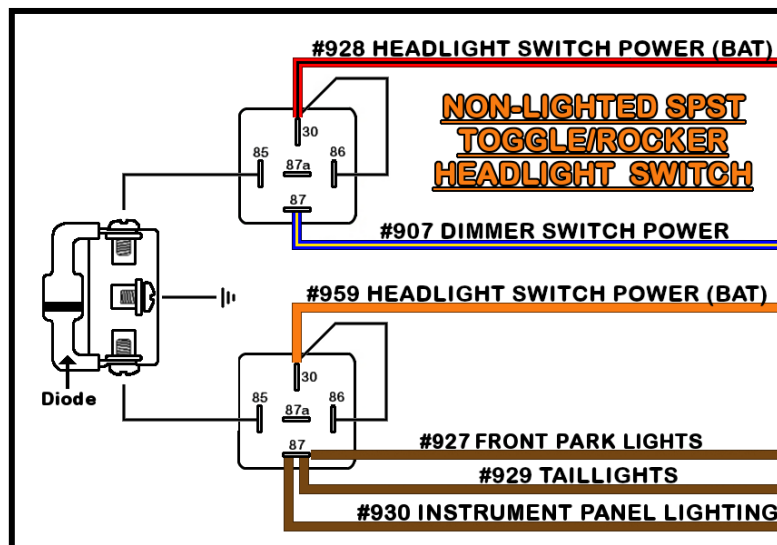

For those using a lighted toggle/rocker switch, connections are the same as a non-lighted only you will need to provide a power source to the backlight of the switch. This will generally be a tab on the back of the switch that is opposite of the terminals for the input and output(s) as seen below.

You can get a battery power 12v source from either the #928 or #959 wires of the headlight switch section.

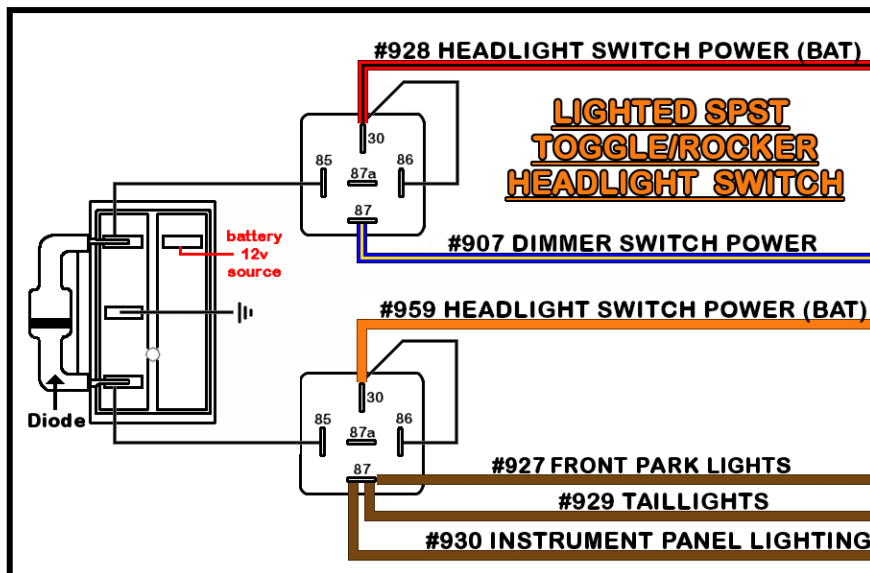

BRAKE SWITCH

The location of the brake switch varies from vehicle to vehicle as this connection depends on the style of switch your vehicle uses.

Hydraulic switches, like Painless part [#80171](#), are mounted in the engine compartment, usually near or on the master cylinder. A mechanical switch, like Painless part [#80172](#) (2-pin) or [#80176](#) (4-pin, also included in our torque converter lockup kits [#60109](#) & [#60110](#)), will be mounted on or near the pivot point of the brake pedal.

If you have a hydraulic switch, see [page 38](#) for instructions. If you are using a mechanical switch you should have re-routed the wires from the engine compartment on [page 18](#). The following steps will guide you on how to connect a mechanical switch.



There are two wires found in the Painless chassis harness for proper brake switch connection, and they are:

ORANGE: 14-gauge wire, printed **[ENGINE SECTION] #917 BRAKE SWITCH (POWER B+)**; which provides power from the 20-amp STOP fuse. This wire always has power.

WHITE: 16-gauge wire, printed **[ENGINE SECTION] #918 BRAKE SWITCH OUTPUT**; this wire supplies power from the brake switch to the brake lights. The wire goes into a splice with 2 other wires, which can be seen in the [Turn Signal Switch & Brake Switch Schematic](#) on the next page.

- Route the brake switch wires to the brake switch and connect them using your factory connector provided or the loose insulated terminals provided in the parts kit. Be sure to route the wires away from the moving parts of the brake pedal and/or clutch pedal.

If your brake switch has four connection pins:

- Two pins will have contact or will be closed when the brakes are not applied. This is usually the pair of terminals closest together. These pins are for cruise control and/or torque converter lockup.
- Two pins will be separate, or open when the brakes are not applied. This is usually the pair of terminals further apart. You will need these two posts that are normally open for brake light function.

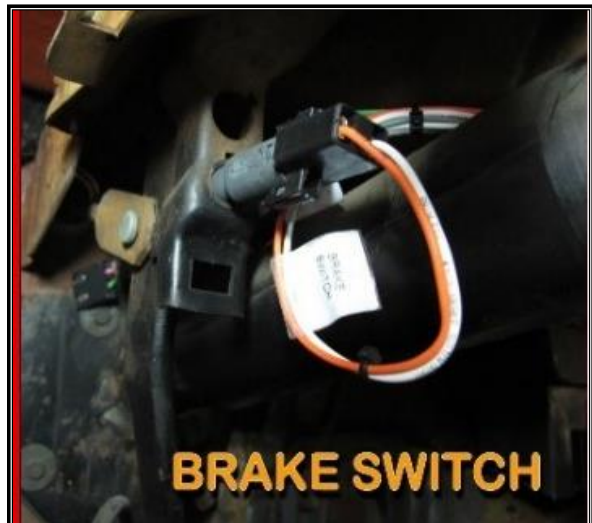

see **FRONT LIGHTING SECTION SCHEMATIC**

see **INSTRUMENT PANEL SCHEMATIC**

TURN SIGNAL SWITCH & BRAKE SWITCH SCHEMATIC

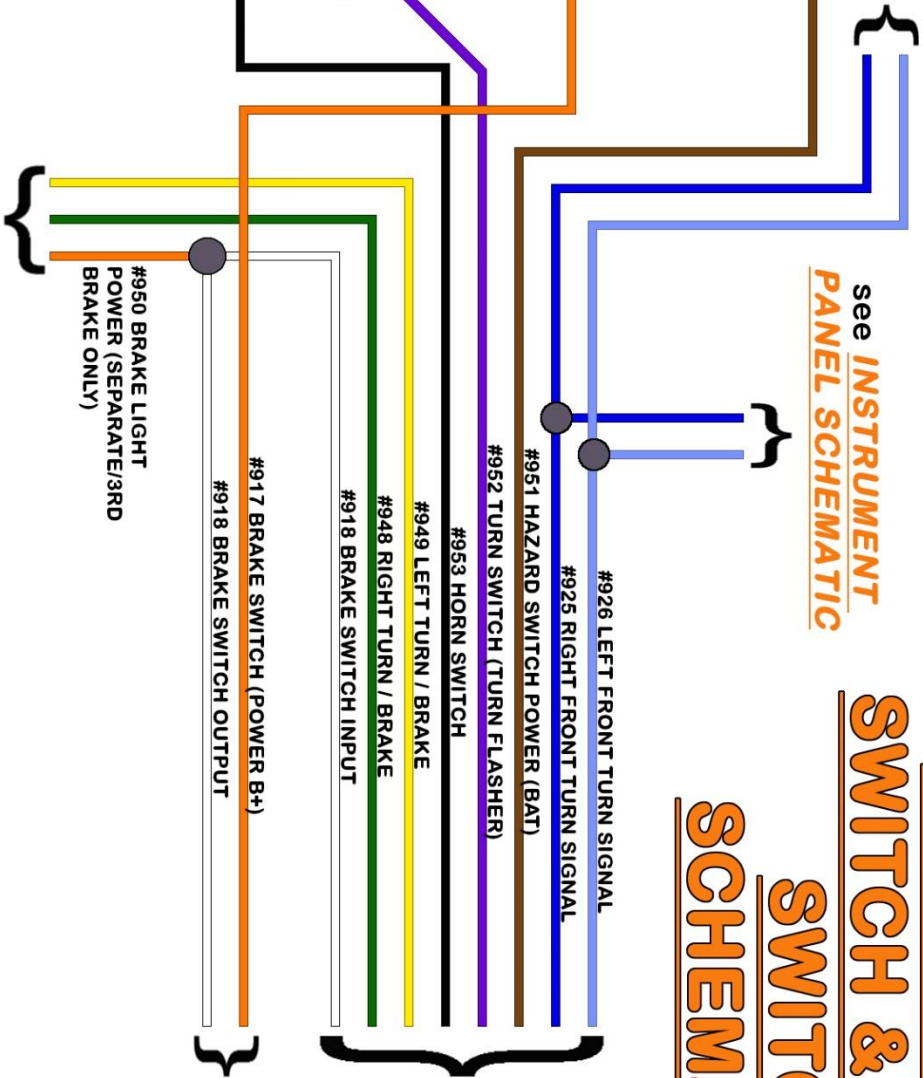
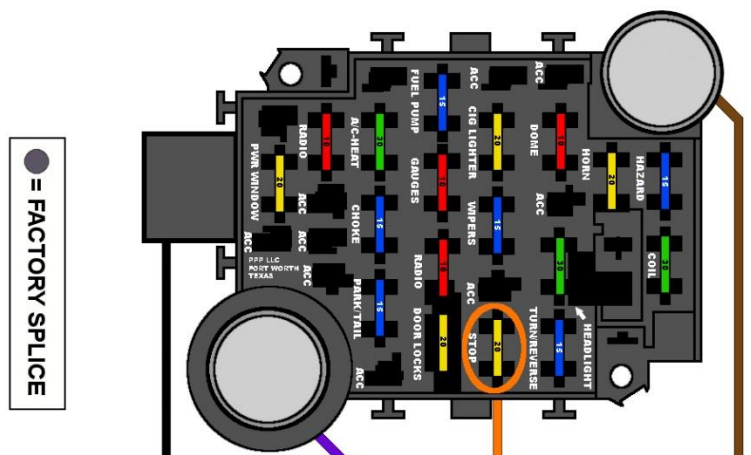

see **TAIL SECTION SCHEMATIC**

TURN SIGNAL SWITCH

BRAKE SWITCH

TURN SIGNAL SWITCH

The turn signal switch provides power to each turn signal and turn signal indicator. For those using a later model or aftermarket GM style column, turn signal switch connectors are provided. As noted on [page 11](#), if you use LED lights, a no-load flasher is required ([Painless part #80230](#)).

In this group of instructions, you will see the term “integrated turn/brake lights.” Most vehicles have integrated lights. This terminology refers to turn signals that also function as brake lights. You can easily tell if your vehicle has integrated turn/brake signals or separate turn/brake lights by looking at the lamp socket(s) on the rear of the vehicle. Only looking at the passenger or the driver's side, how many sockets going into red lenses do you see?

Integrated turn brake signal vehicles will usually have 1 socket per side with a dual filament bulb (brighter filament for turn/brake, dimmer filament for taillights). You can also have vehicles that have integrated lights but also have multiple sockets and lenses.



Separate turn brake signal vehicles will usually have 2 or 3 sockets: 1 socket with dual filaments (brighter filament for brake, dimmer for tail) and 1 socket with a single filament for the turn signal. Remember to count the bulb filaments or the contacts on the bottom of the bulb, not the wires going to them, as your sockets may or may not have ground wires.



The wires provided in the Painless harness for turn signal connection can be identified by the wires reading "TURN SWITCH." These wires can be seen in the [Turn Signal Switch & Brake Switch Schematic](#) on [page 81](#), they are:

LT. BLUE: 18-gauge wire, printed **[TURN SWITCH] #926 LEFT FRONT TURN SIGNAL**; this wire provides power to the front left turn signal. This wire has power anytime the hazard switch is activated and when the turn signal lever is in the down/left turn position and the ignition switch is in the ON/RUN position.

BLUE: 18-gauge wire, printed **[TURN SWITCH] #925 RIGHT FRONT TURN SIGNAL**; this wire provides power to the front right turn signal. This wire has power anytime the hazard switch is activated and when the turn signal lever is in the up/right turn position and the ignition switch is in the ON/RUN position.

WHITE: 14-gauge wire, printed **[TURN SWITCH] #918 BRAKE SWITCH INPUT**; this wire feeds the brake light power into the turn signal switch for vehicles with integrated turn/brake signals. This wire has power anytime the brake pedal is pressed. **Those with separate turn and brake lights will not need this WHITE #918 wire.**

YELLOW: 16-gauge wire, printed **[TAIL SECTION] #949 LEFT TURN / BRAKE**; this wire provides power to the left rear turn signal. This wire has power anytime the hazard switch is activated and when the turn signal lever is in the down/left turn position and the ignition switch is in the ON/RUN position. On vehicles with integrated turn/brake lights, this wire also carries the brake light power. In those cases, this wire will also have power anytime the brake pedal is pressed.

GREEN: 16-gauge wire, printed **[TAIL SECTION] #948 RIGHT TURN / BRAKE**; this wire provides power to the right rear turn signal. This wire has power anytime the hazard switch is activated and when the turn signal lever is in the up/right turn position and the ignition switch is in the ON/RUN position. On vehicles with integrated turn/brake lights, this wire also carries the brake light power. In those cases, this wire will also have power anytime the brake pedal is pressed.

BROWN: 16-gauge wire, printed **[TURN SWITCH] #951 HAZARD SWITCH POWER (BAT)**; this wire provides power to the hazard switch. It comes from the hazard flasher found on the fuse block. It is a battery power wire, but it has power only when the hazard switch is activated which causes the flasher to send power through this wire. See [Flashers](#) on [page 11](#) for how this process works.

PURPLE: 16-gauge wire, printed **[TURN SWITCH] #952 TURN SWITCH (TURN FLASHER)**; this wire provides power to the turn signal switch. It comes from the turn signal flasher found on the fuse block. It is an ignition power wire, but it has power only when the turn signal switch is activated, which causes the flasher to send power through this wire. See [Flashers](#) on [page 11](#) for how this process works.

BLACK: 18-gauge wire, printed **[TURN SECTION] #953 HORN SWITCH**; this wire is a ground activation signal to the horn relay. The only time this wire is grounded is when the horn button on the steering wheel contacts a ground source.

- Route the turn signal wires to the turn signal switch and cut to length if terminals are not pre-installed.
- Use one of the following turn switch diagrams and connect each wire of the **Turn Signal Switch Section** to its correct connection.
- If a diagram is not provided, a factory schematic for your vehicle may be needed to figure out your connections.

GM COLUMNS / AFTERMARKET GM STYLE COLUMNS

- Locate the black connectors in the kit that fit your column. Those with a **10202** & **10204** harness without terminals pre-installed also need to locate the terminals in the bag kit. Most columns will use the plug seen to the right, which is found on most aftermarket columns, as well as GM columns from the mid-1970s onward. These GM columns are a popular retrofit item because of their key on the column and tilt function.
- Using the diagram on the next page, pin each wire into its correct location on the connector. Remember, **WHITE #918** will only be connected if you have integrated brake lights.
- If you use the connector, once all wires have been installed, fold the locking tab down onto the connector. It will click/snap and lock the terminals in their place.
- Connect the now installed connector onto the connector on the steering column.

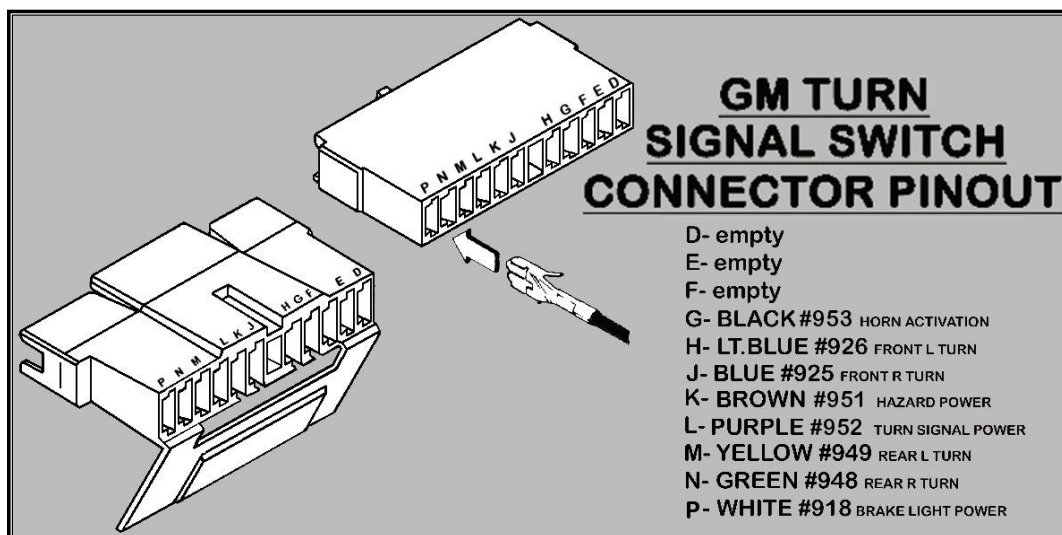

FORD COLUMNS

For those with Ford columns, the connector that plugs into the column from a factory harness will be needed. When it is cut from the factory harness leave 4-6" of wire to make it easy to splice/connect it to the wires on the new Painless harness. Those that do not have access to the connector that plugs into the column connector, cut the connector off the column, and splice/connect directly to the wires in the column.

If a mate to your column connector is not available Painless recommends putting an in-line connection to make removal of the harness or column easy. Connector kits such as #40010 and #40011 would provide such a connection; allowing you to install a connector onto the new Painless harness as well as a mate to this connector onto the wires on your column.

Diagrams, as well as a chart, have been provided to help identify the factory wires found on your column. **Your column may differ from the information provided as there are numerous different columns.**

- Using the splices provided in the parts kit, splice each wire of the "TURN SIGNAL SECTION" to your factory connector or directly to the wires coming from your column.

<u>FORD COLOR</u>	<u>DESIGNATION</u>	<u>PAINLESS WIRE #</u>	<u>PAINLESS COLOR</u>
GRN, RED/BLK	Brake Light Power	918	WHITE
WHT/BLU	Front Right Turn Signal	925	BLU
GRN/WHT	Front Left Turn Signal	926	LT. BLU
ORN/BLU, GRN	Rear Right Turn Signal	948	GRN
GRN/ORN, YLW/BLK	Rear Left Turn Signal	949	YLW
WHT/RED	Hazard Power	951	BRN
BLU, BLU/YLW	Horn	953	BLK
BLU	Turn Signal Power	952	PURP

If you are using a Painless connector kit, use the supplied terminals provided with that kit.

FORD "SEMI CIRCLE" TURN SIGNAL SWITCH CONNECTOR

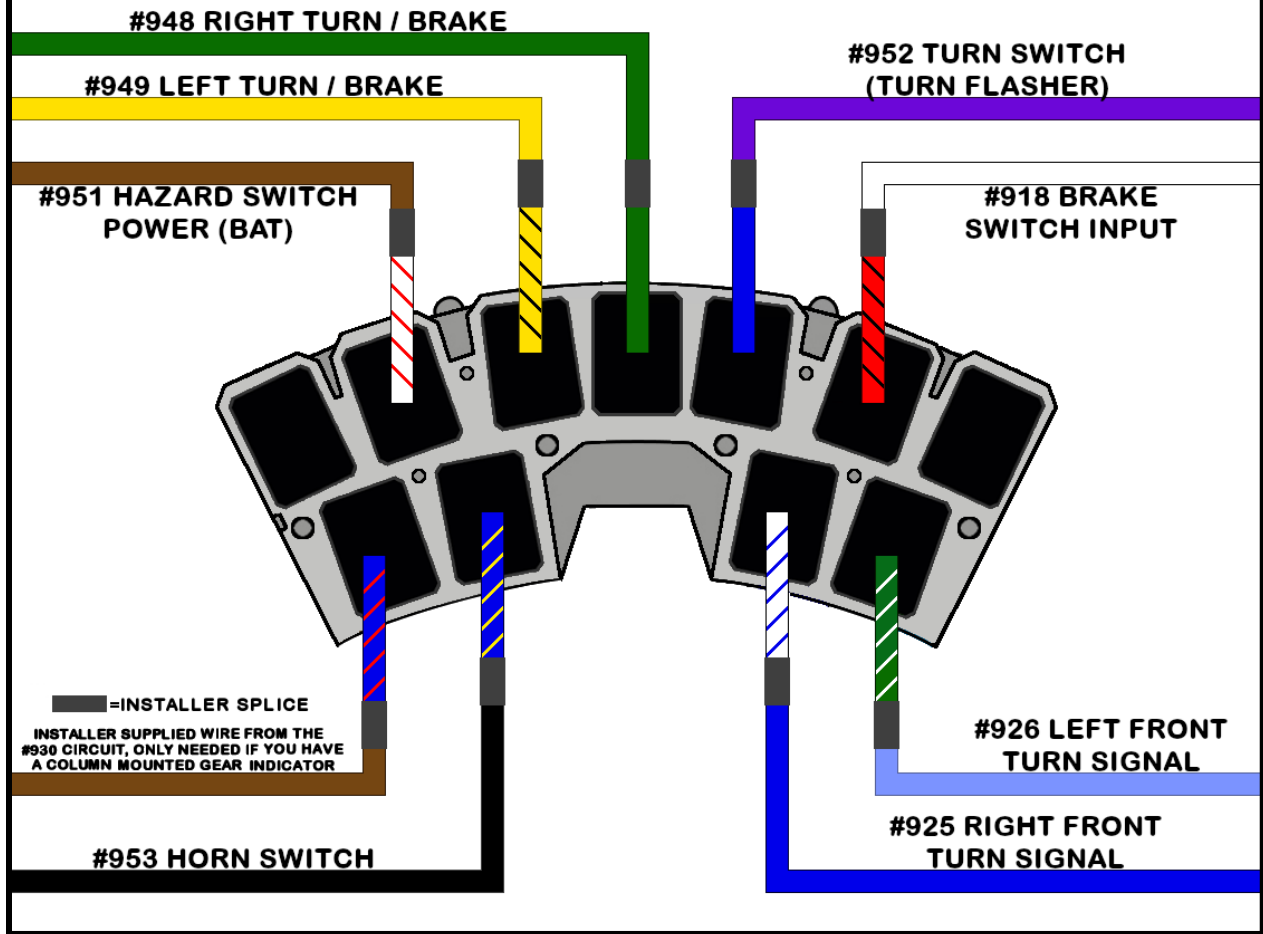

FORD TURN SIGNAL CONNECTOR (W/O HAZARD)

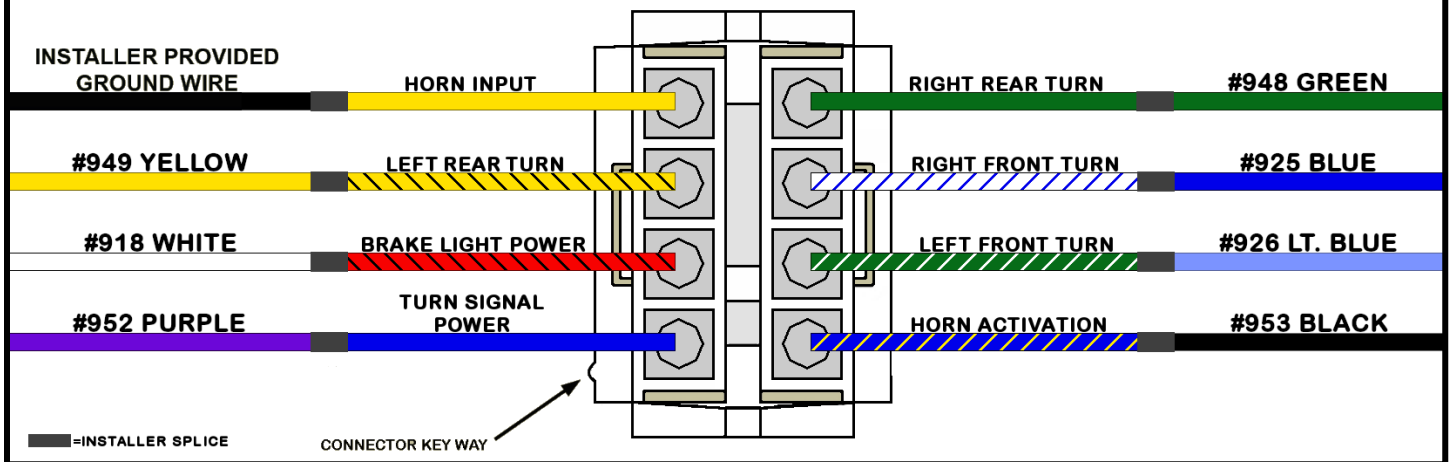

The diagrams above show splicing the wires from the Painless harness to an installer created pigtail from factory wiring.

MOPAR COLUMNS

For those with Mopar columns, the connector that plugs into the column from a factory harness will be needed. When it is cut from the factory harness leave 4-6" of wire to make it easy to splice/connect it to the wires on the new Painless harness. Those that do not have access to the connector that plugs into the column connector, cut the connector off the column, and splice/connect directly to the wires in the column.

If a mate to your column connector is not available Painless recommends putting an in-line connection to make removal of the harness or column easy. Connector kits such as #40010 and #40011 would provide such a connection; allowing you to install a connector onto the new Painless harness as well as a mate to this connector onto the wires on your column.

Diagrams, as well as a chart, have been provided to help identify the factory wires found on your column. **Your column may differ from the information provided as there are numerous different columns.**

- Using the splices provided in the parts kit, splice each wire of the "TURN SIGNAL SECTION" to your factory connector or directly to the wires coming from your column.

If you are using a Painless connector kit, use the supplied terminals provided with that kit.

<u>MOPAR COLOR</u>	<u>DESIGNATION</u>	<u>PAINLESS WIRE #</u>	<u>PAINLESS COLOR</u>
WHT	Brake Light Power	918	WHITE
TAN, BLU	Front Right Turn Signal	925	BLU
GRN, LT. GRN	Front Left Turn Signal	926	LT. BLU
BRN, BRN/RED	Rear Right Turn Signal	948	GRN
GRN, GRN/RED	Rear Left Turn Signal	949	YLW
PNK, BLK	Hazard Power	951	BRN
RED	Horn	953	BLK
BLK, BLK/RED	Turn Signal Power	952	PURP

EXTERNAL / CLAMP-ON COLUMN MOUNTED SWITCH

There are many versions of this typical “hot rod/street rod” style switch. In most cases, this type of switch will have wires coming from it to which the chassis harness will connect. **Do not try to match the color of the wires on your switch to the colors found on the Painless harness.** Due to so many variations and manufacturers of this type of switch, a specific pinout/ schematic cannot be given for every switch. Below is a schematic with the most common way to connect one of these switches into the Painless harness. This diagram covers popular models from Grote & Speedway.



Note: The colors in the diagram reflect those found in many Grote and cheaper, aftermarket switches. However, they may not match your switch. Please refer to manufacturer instructions to ensure you are connecting the proper wires.

If your clamp-on switch has an indicator light, then a 3-pin flasher is generally required. This will allow the onboard indicator lights of the switch to function properly. The Painless harness you are installing comes equipped with two 2-pin flashers which obviously will not work, and the fuse block does not have a provision for a 3-pin flasher. However, the pre-installation steps on [page 17](#) covered the initial steps on how to integrate a 3-pin flasher into the Painless system.

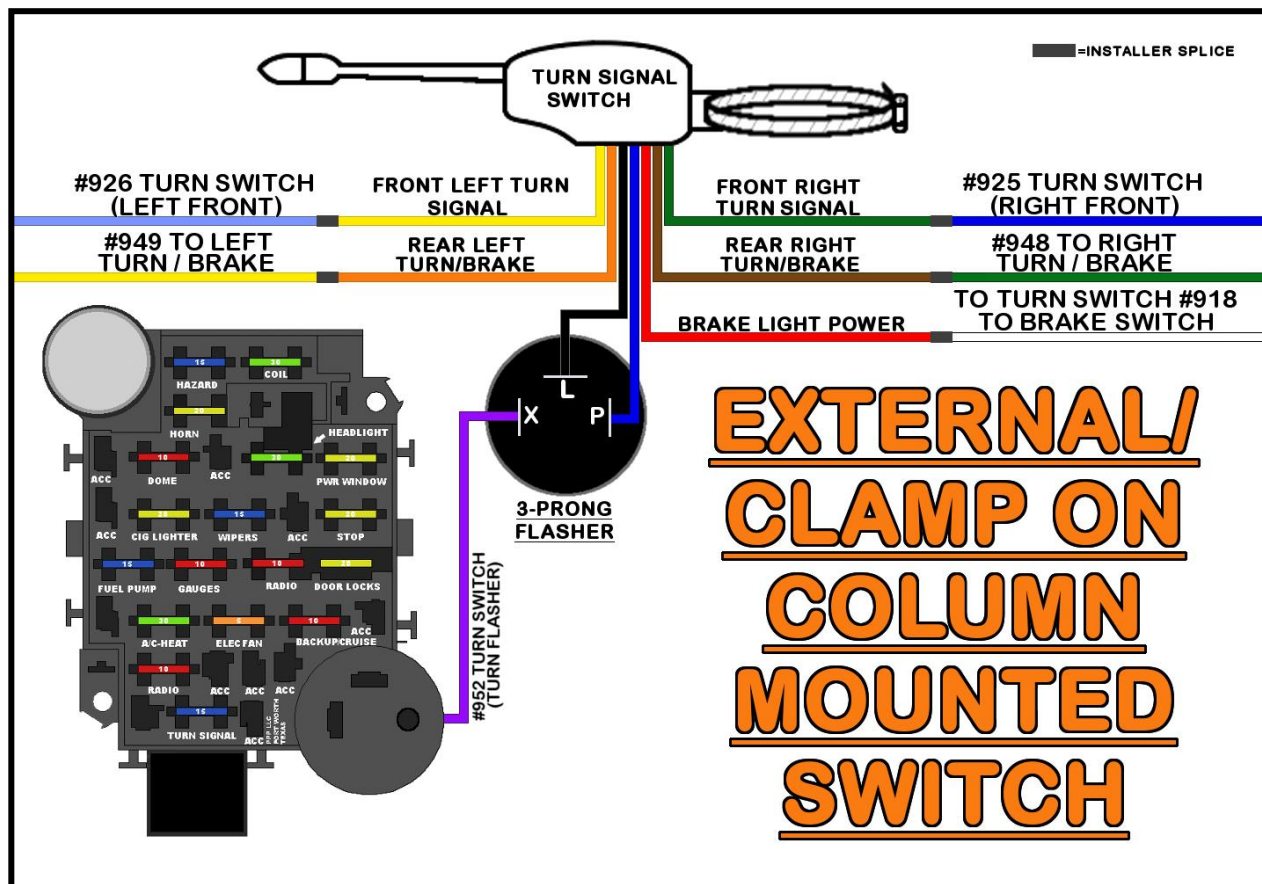

- The **PURPLE** wire from the Painless harness will provide the flasher relay with power. On most 3-pin flashers, this will be either the terminal labeled “X” or “B.”
- The other two prongs will wire to the switch wiring. The “L,” or “load” terminal will provide the load to the turn signal switch. The “P” or Pilot will go to the indicator light.
- As stated before, do not try to match the switch colors to the Painless harness colors, as there are many variations in switches. Follow the manufacturers’ instructions on proper connections of the wires from the switch.

SPDT TOGGLE SWITCH

If you do not have a turn switch, a simple On-Off-On SPDT switch can be used for this function. Please be aware that the diagram and instructions provided below are for separate turn/brake light vehicles only. Those with integrated lights are encouraged to purchase a clamp-on turn signal switch as seen on the previous few pages.

- Connect the **PURPLE** wire to the input of the switch.
- Connect the front and rear left turn signal wires, **#926 & #949**, to one position on the switch.
- Connect the front and rear right turn signal wires, **#925 & #948**, to the remaining position on the switch.

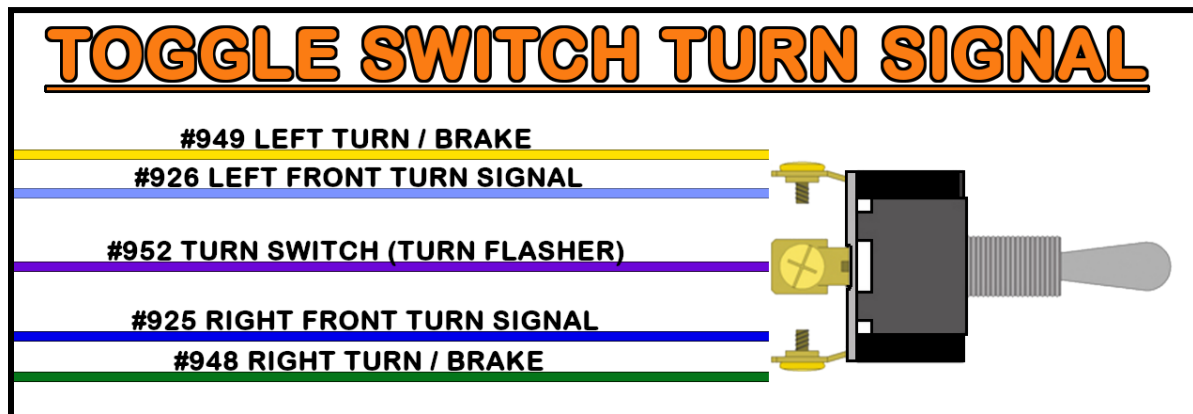

HAZARD SWITCH

If you do not have a factory style hazard switch, a 3PST On-Off switch can be used for this function. Painless offers part #30122.

- Connect the BROWN wire from the hazard flasher to all 3 poles of the switch by chaining the terminals together. This wire provides power from the flasher to the switch.
- Then, connect wires, represented as #918, #925, & #926 to the other 3 terminals. These wires connect the brake lights, as well as the front turn signals to the hazard switch.

The #925, & #926 will splice to the #925, & #926 wires at the turn signal switch, #918 will splice to the #918 at the output of the brake switch.

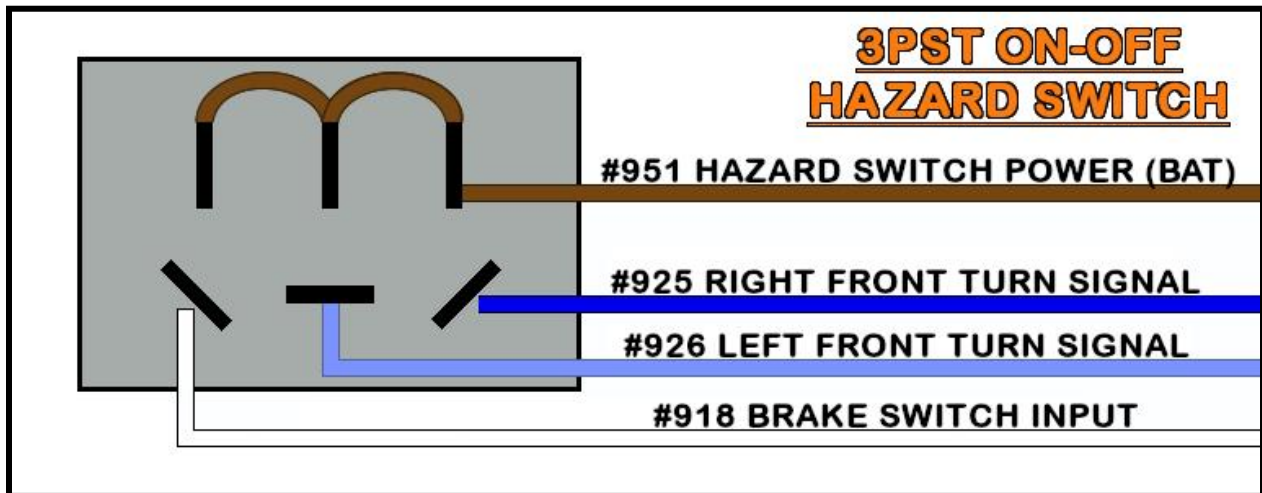

Also, a simple SPST On-Off switch can be used to flash only the brake lights in the event of an emergency. **This diagram will not flash the front turn signals like a traditional hazard flasher which your local laws may require.**

- Connect the **BROWN** power wire from the flasher to the switch. If you have separate turn brake lights, #918 can connect directly to the toggle.
 - If you have integrated lights, then run a wire from the toggle switch and splice it into the #918 wire.

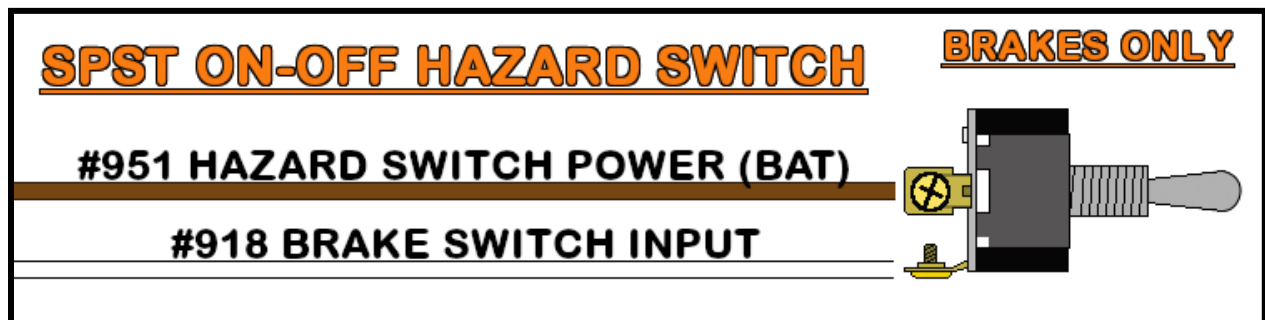

HORN BUTTON

If you are using an external/clamp turn signal or a toggle switch for turn signal activation, the **BLACK #953** wire found in the **Turn Signal Section** will be for horn function.

- If you have a horn button on the column, the connection will depend on if you have a 1 or 2 wire horn button.
- Connect the **BLACK #953** wire found in the **Turn Signal Section** to the horn button.
 - If your horn button has 1 wire, this is all you need to do as your horn button is grounded through the mounting.
 - If your horn button has 2 wires, connect a user-supplied ground wire to the other wire.
- If your column does not have a horn button, a momentary SPST switch can be used. This switch will have 2 prongs, toggle switches will look identical to the one seen above. Connect **#953** to one prong and a user-supplied ground wire to the other.

IGNITION SWITCH

The most important connection of a wiring harness, the ignition switch, controls power to the switched ignition fuses in the fuse block as well as sending power to the starter solenoid to crank the engine. The wires in this section vary slightly between the **10201/10203** kits and the **10202/10204** kits. Kits **10201** & **10203** are intended for GM Keyed Columns; therefore, they come with a connector pre-installed (see [page 91](#)).

The ignition switch connection consists of 2 sets of wires with section labels reading "IGNITION SWITCH." All wires going to the ignition switch can be seen in the [Ignition Switch Schematic](#) below. **Note: kits 10201 & 10203 have no printing on the wires. These wires are:**

RED: (2) 12-gauge wires, printed **[IGNITION SWITCH] #934 IGNITION SWITCH POWER (BAT)**; these wires come from a buss bar on the fuse block and feed battery power to the ignition switch. These wires always have power. **10202 & 10204** only have one **RED #934** wire.

ORANGE: 12-gauge wire, printed **[IGNITION SWITCH] #933 SWITCHED (IGN) POWER TO FUSE BLOCK**; this wire provides the switched power source to the fuse block. This wire powers all the switched power circuits to the harness except for the COIL, RADIO, TURN SIGNAL, and A/C-HEAT fuses. This wire only has power when the ignition switch is in the ON/RUN position.

PINK: 14-gauge wire, printed **[IGNITION SWITCH] #931 IGN POWER TO "COIL" FUSE**; this wire provides power from the ignition switch to the 30-amp COIL fuse on the fuse block. This wire has power when the ignition switch is in the ON/RUN position as well as the START position.

PURPLE: 12-gauge wire, printing varies depending on the harness (see below). This wire sends power to the starter solenoid and only has power when the ignition switch is in the START position.

- **10201 & 10203:** printed << **[IGNITION SWITCH] << #919 >> [NEUTRAL SAFETY SWITCH] >>**; this wire is hanging free from the pre-installed ignition switch connector. The other end of this wire routes to the NSS, just like the **#919 PURPLE** wire from the starter solenoid. See [page 100](#) for more information on the NSS.
- **10202 & 10204:** printed << **[ENGINE SECTION] TO STARTER SOLENOID << #919 >> [IGNITION SWITCH] >>**; this wire leads directly to the starter solenoid. If you are incorporating an NSS, this wire should have been rerouted on [page 18](#). See [page 100](#) first for more information on the NSS.

BROWN: 12-gauge wire, printed **[IGNITION SWITCH SECTION] #932 ACCESSORY POWER**; this wire carries power to the RADIO, TURN SIGNAL, and A/C-HEAT fuses on the fuse block. This **BROWN** wire has power when the ignition is in the ACCESSORY position and when in the ON/RUN position.

Since there are so many different types of ignition switches, chose from one of the following that best fits your application:

GM COLUMN MOUNTED (PRE-TERMINATED ON 10201 & 10203)

Many of the popular retro-fitted GM columns people use in their vehicles have the ignition key on the column. The diagram and instructions below demonstrate how to properly connect to this type of ignition switch.

- Locate the ignition switch on the top of the steering column, seen in the photos below, and route the "IGNITION SWITCH" wires to the switch.
- **The connectors must be installed in a specific order;** the clear connector needs to be attached first, and then the black. Part of the black connector will overlap the clear connector.

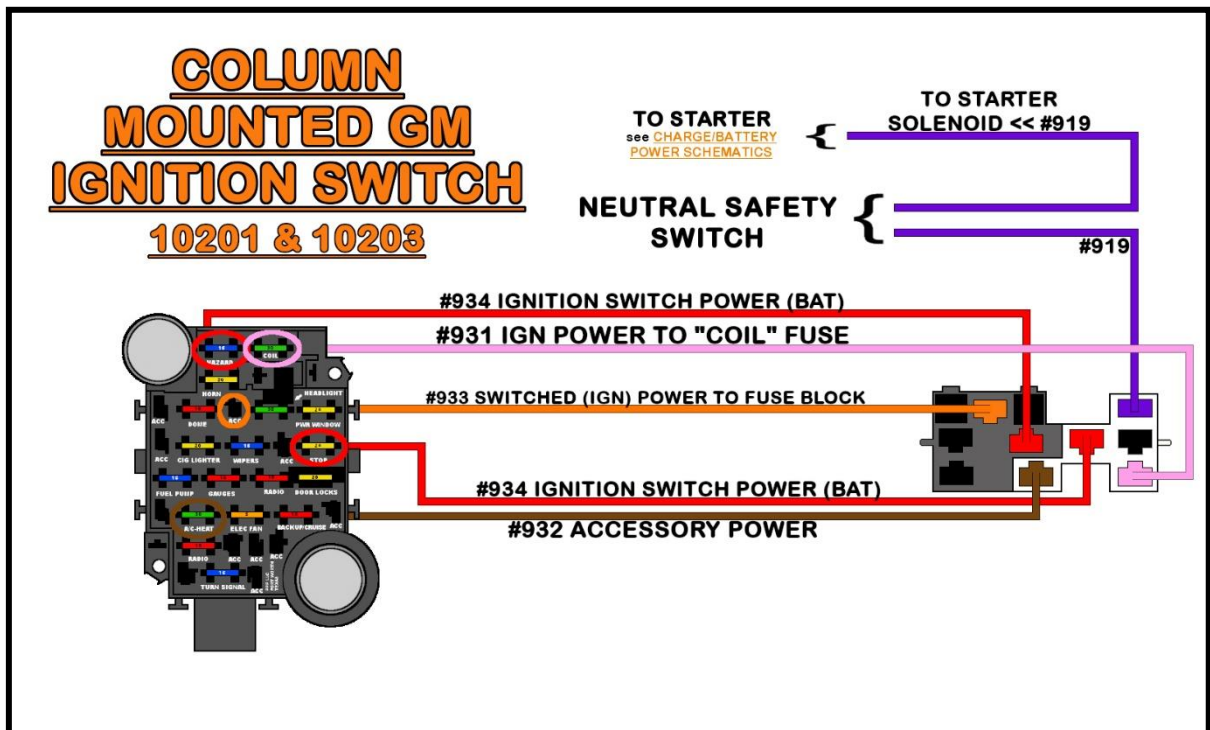

GM DASH MOUNTED (10202 & 10204)

Your vehicle may have one of the many different dash-mounted ignition switches. Some have functions printed next to each pin on the switch; this allows for identification as to where each wire connects. Others will need a factory schematic to identify the functions of their switch. Below, there are diagrams showing the proper connection of a few of these popular switches.

Since there are so many different types of ignition switches, chose from one of the following that best fits your application:

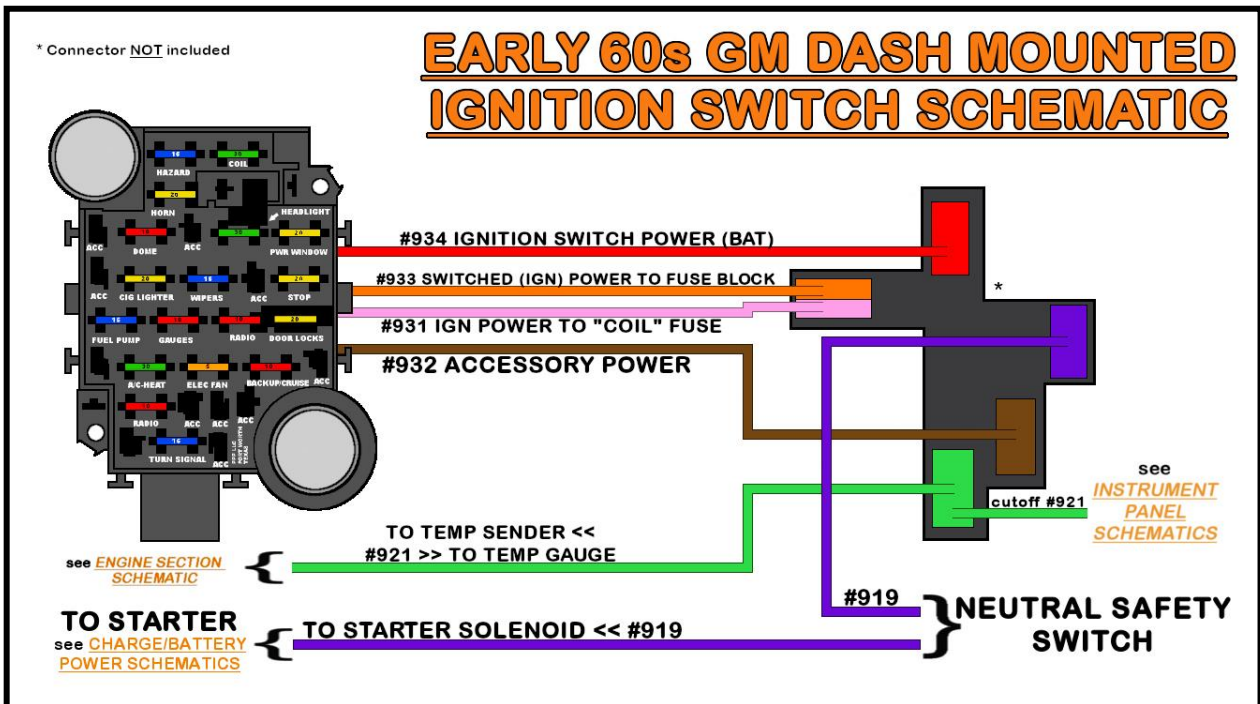
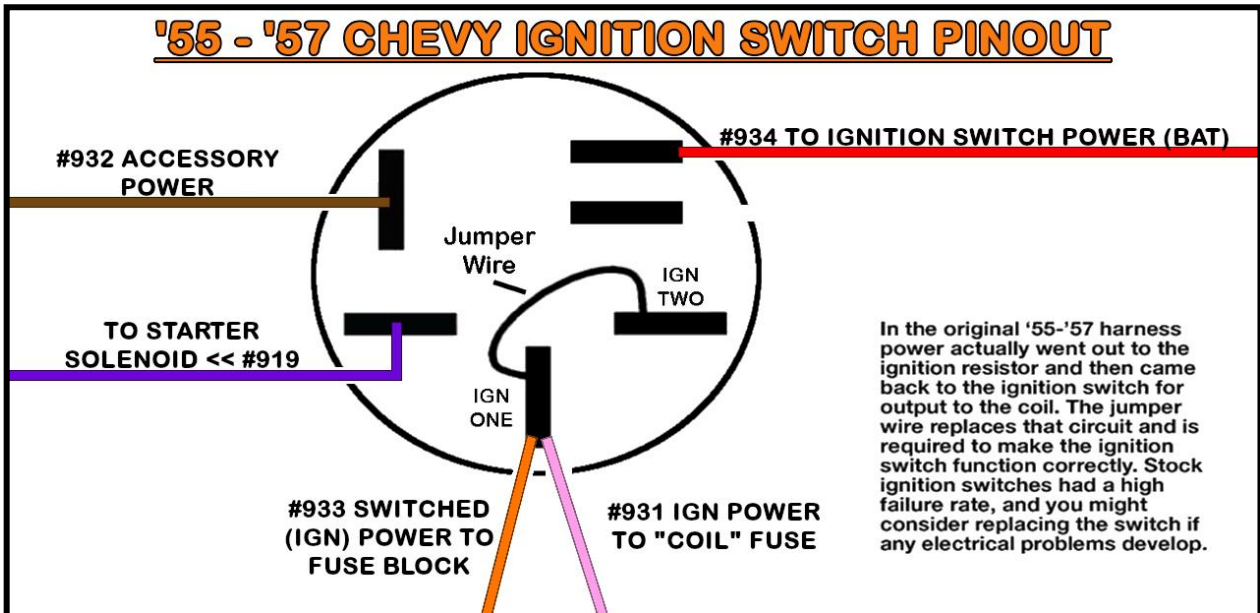

MID TO LATE 60s GM DASH MOUNTED IGNITION SWITCH SCHEMATIC

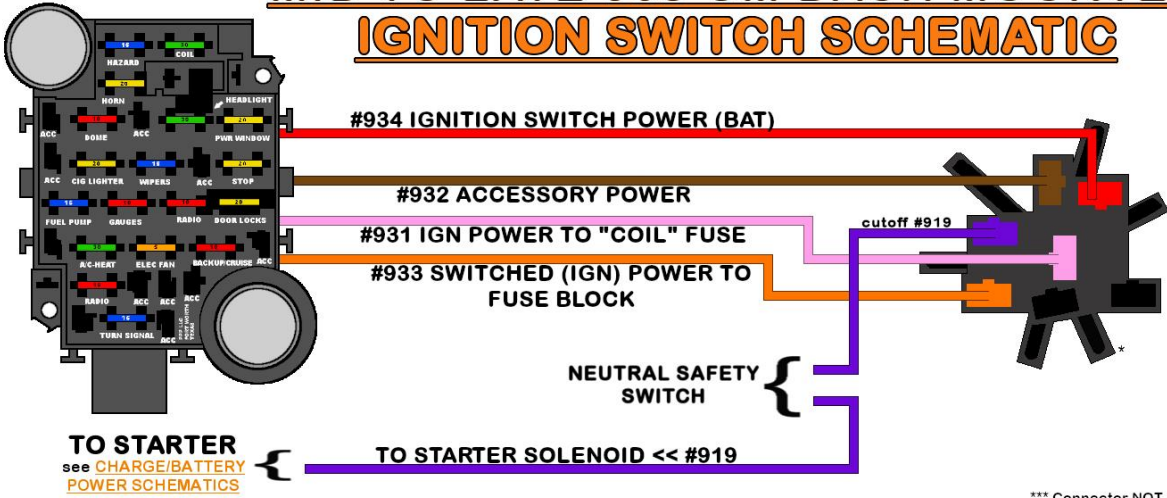

'67 - '72 GM TRUCK DASH MOUNTED IGNITION SWITCH SCHEMATIC

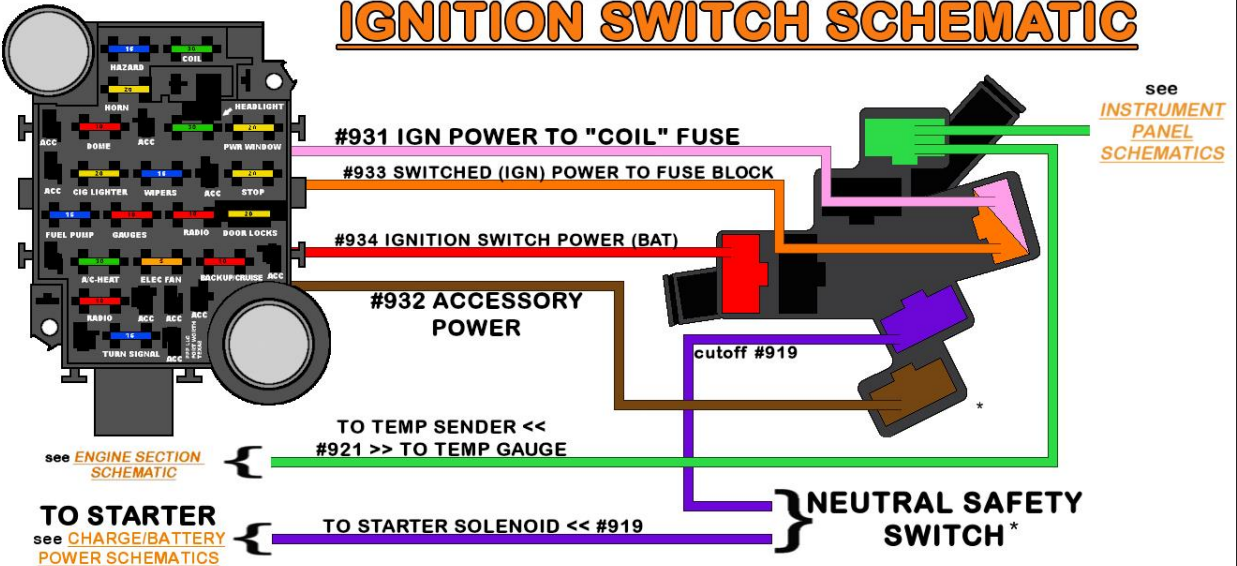

FORD KEY ON THE DASH

Below you will see a diagram of a common Ford dash-mounted ignition switch. This switch was used on many cars and trucks throughout the 1960s and 1970s. It is easily identified by a thread post that comes out of the center, position C in the drawing below.

Pin D will provide a ground source to the warning lights when the ignition switch is in the ON position and the vehicle is not running. This will give the driver a visual indication that all warning lights have functioning bulbs. Connections for this pin are not supplied in this harness but can easily be added by the installer.

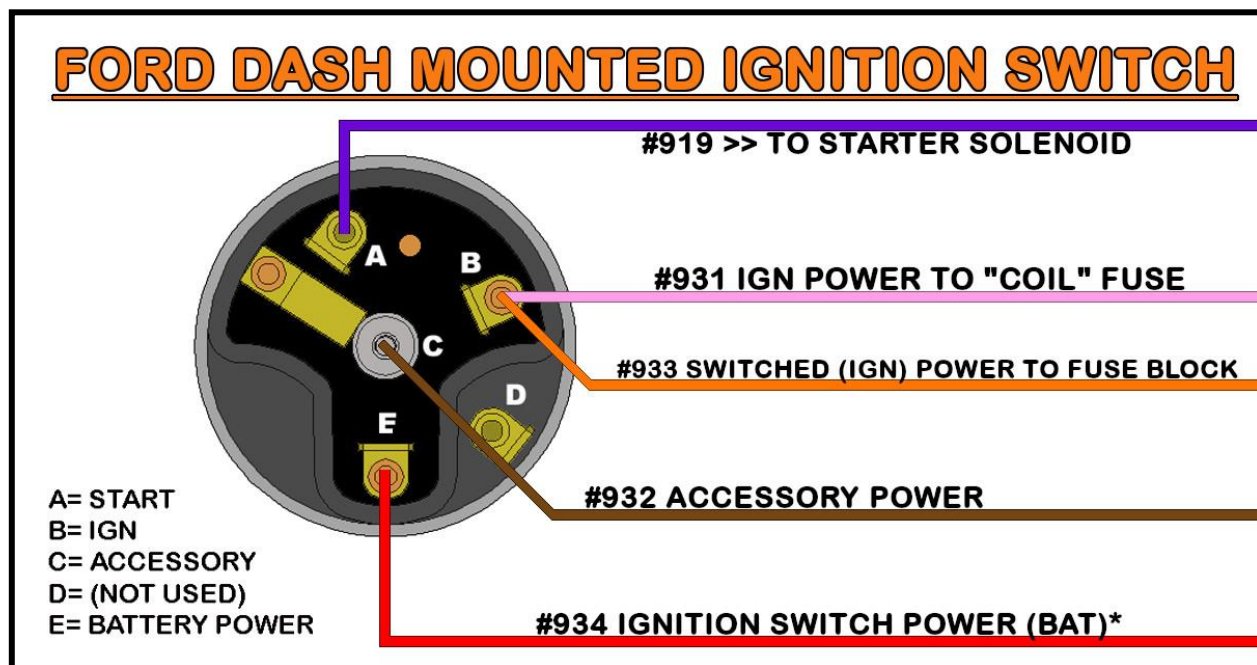

PAINLESS UNIVERSAL IGNITION SWITCH - #80153

Painless offers a universal, dash mount ignition switch. This switch comes with the trim ring, which screws onto the switch to hold the switch in place, as well as 2 keys. The switch can be found as part [#80153](#) or in switch kit [#80121](#).

- Use insulated ring terminals, found in the parts kit, to make these connections.

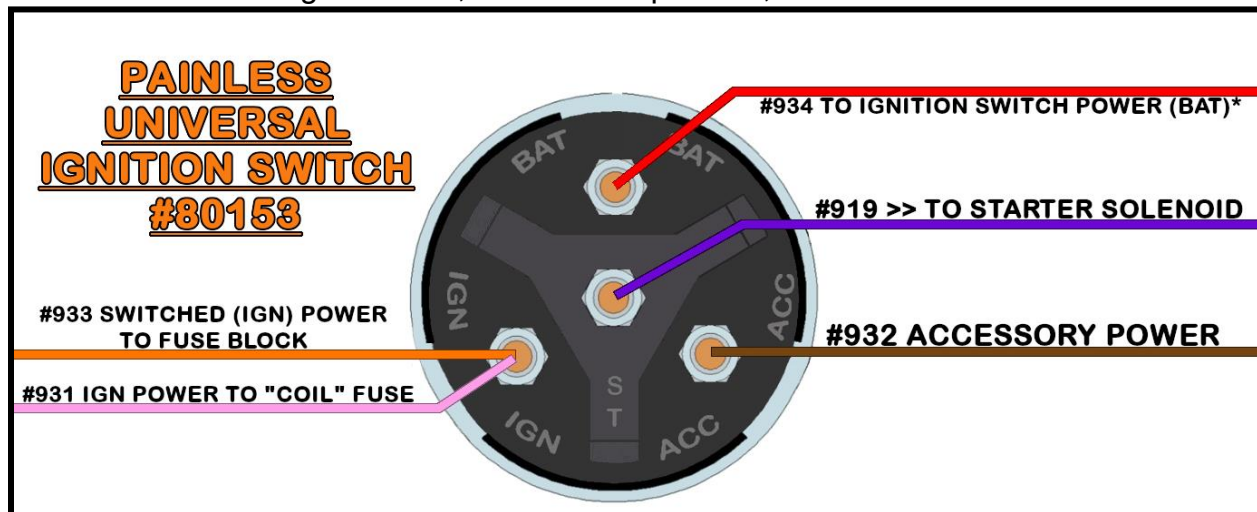

REVERSE SWITCH

The reverse switch connection provides the backup lights the power they need to illuminate. This switch is a 2-pin, normally open switch that has power coming into one side and out the other to the backup lights. When the shifter is put into the reverse position, contact is made between these 2 pins, closing the switch. This allows power to flow from one pin to another, thus transferring power through the switch out to the backup lamps. The 2 wires provided for this option are:

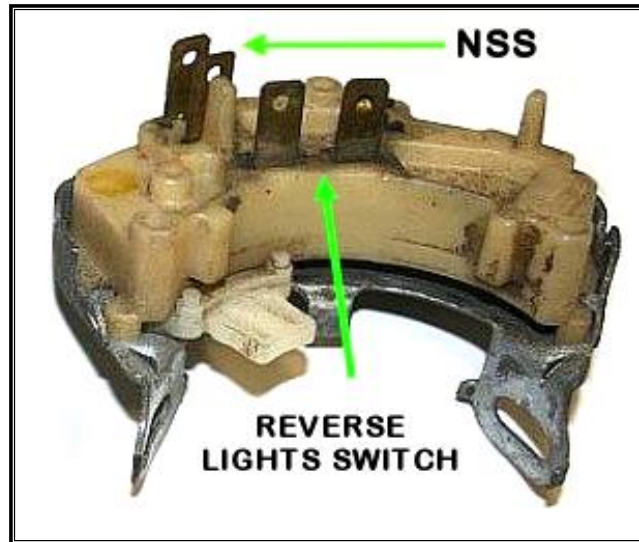

LT. GREEN: 18-gauge wire, printed [REVERSE SWITCH] #958

REVERSE SWITCH POWER (IGN); this wire comes from the 10-amp BACKUP / CRUISE fuse on the fuse block. This wire is a switched ignition power wire meaning it will only have power when the ignition switch is in the ACCESSORY and ON/RUN positions.

If you do not have back up lights, #958 can be used to power an accessory requiring a switched 12v power source.

LT. GREEN: 18-gauge wire, printed [REVERSE SWITCH] #956 **OUTPUT TO REVERSE LIGHTS;** this wire provides power from the reverse switch to the backup lights in the Tail Section of the Painless harness.

- Locate the reverse switch; the location varies depending on your vehicle.

Many of those using a factory GM column can find it at the base of the steering column as seen on the next page.

This same switch can be found at the base of factory console shifters.

- Route the wires to the reverse switch, cut to length, and strip $\frac{1}{4}$ " of insulation.
- A connector and terminals are provided for those with the factory reverse switch seen above. It does not matter which tab each wire connects to.

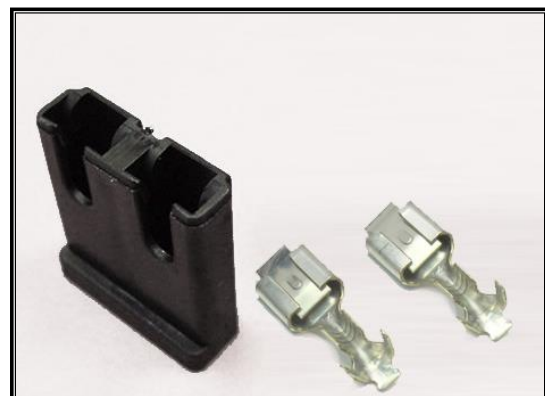

- If you are using an aftermarket floor-mounted shifter, the reverse switch may be found on the base of the shifter. There may also be a neutral safety switch found on the shifter as well. When testing the system, if you notice the reverse lights on when the transmission is in park or neutral, you have the reverse switch wires connected to the neutral safety switch.

Small, insulated terminals have been provided in the parts kit to accommodate aftermarket shifter switches.

- **Painless offers part #80175** for those using GM TH350, TH400, 700-R4, TH200, 200-4R, & 4L 60 transmissions. This part can be used as either a reverse switch or a neutral safety switch.

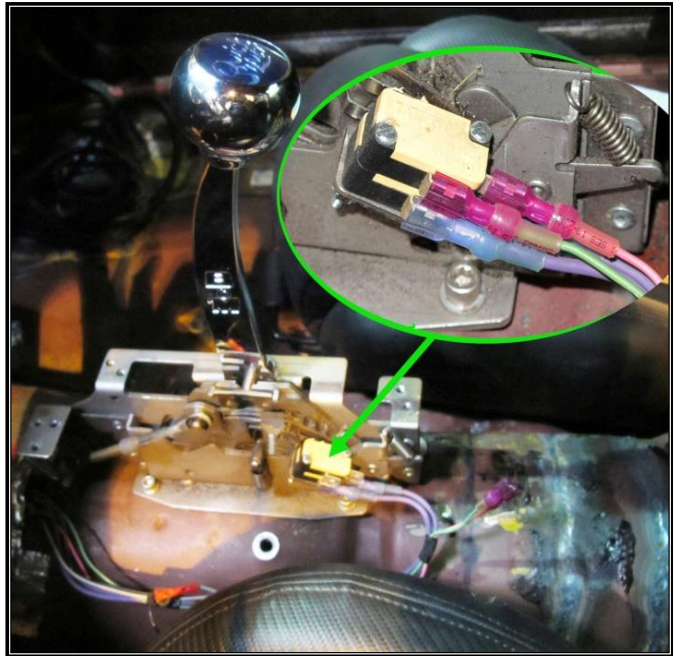

CRUISE CONTROL SWITCH

Also, in this section, is a 12v switched power wire for the cruise control switch if you are using one. This wire is:

PINK: 18-gauge wire, printed **[CRUISE CONTROL SECTION] #957 CRUISE CONTROL SWITCH / ACC. POWER (IGN)**; this wire comes from the 10-amp BACKUP / CRUISE fuse on the fuse block. This wire is a switched ignition power wire meaning it will only have power when the ignition switch is in the ACCESSORY and ON/RUN positions.

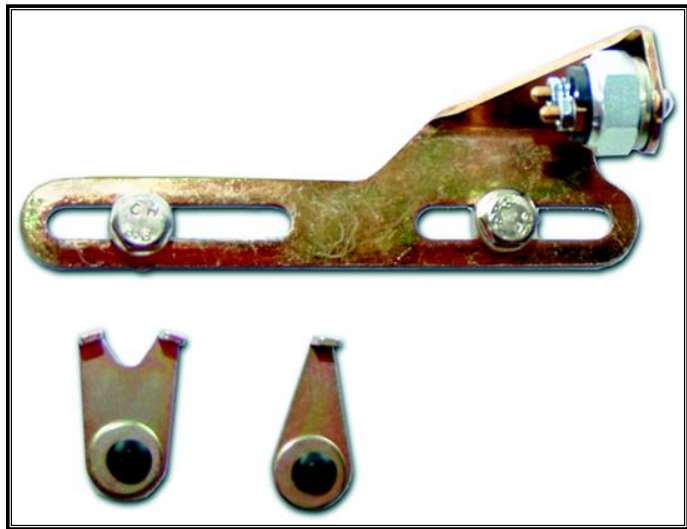

If you do not have cruise control, **#958** can be used to power an accessory requiring a switched 12v power source. Route this wire directly to the cruise control module and connect, or if you are using a 4-pin brake switch, route the **PINK #957** wire to one terminal on the brake switch. Cut to length and connect the wire. Then, connect the cut-off portion to the other terminal on the brake switch. Finally, route it to the cruise control module, and connect.

4L60E/4L80E SWITCH

The 4L60e/4L80e transmission, from trucks or SUVs, has a factory reverse switch on the shift detent rod on the driver's side of the transmission. This same switch also has a park/neutral switch incorporated. Use the diagrams below to connect the reverse wires of the Painless harness to this switch.

For those with a 4L60e/4L80e transmission, a starter relay must be used (not supplied) unless you use a factory switch on a GM Keyed column. The switch is not capable of handling the amperage the solenoid requires.

The following section of this manual, Neutral Safety/Clutch Switch, contains information on the starter relay shown in the diagrams. The wires of the Painless harness will need to splice to the existing wires coming from your switch connector.

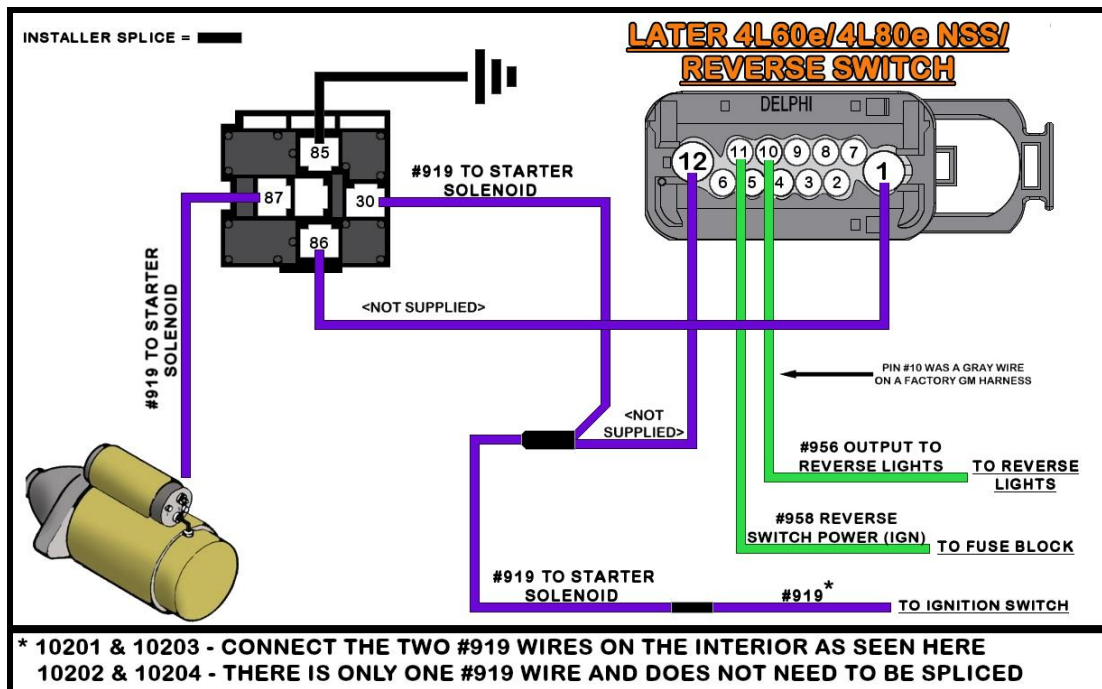
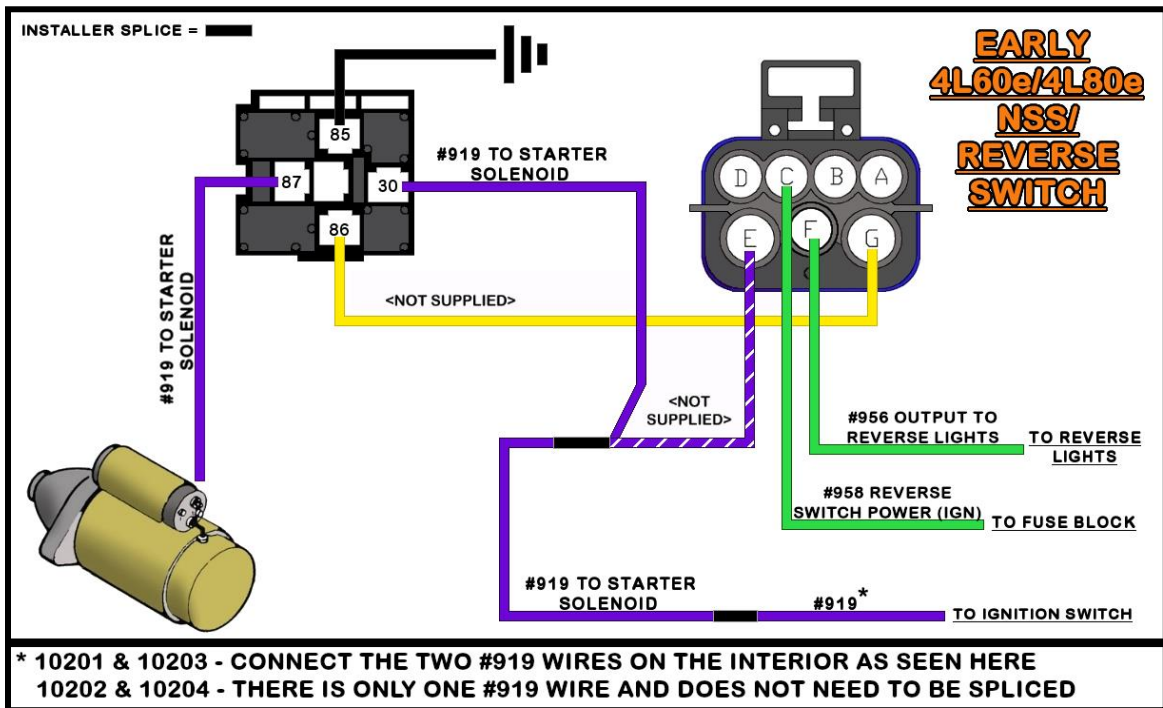

NEUTRAL SAFETY / CLUTCH SWITCH

This switch is a safety device that prevents the vehicle from being started while in gear and causing an unfortunate accident. The purpose of this switch is to only allow the engine to be started when the vehicle is in park or neutral (automatic transmissions) or if the clutch pedal is depressed (manual transmissions). When the transmission is put into park/neutral or the clutch pedal is depressed, contact is made between these 2 pins, closing the switch. This allows power to flow from one pin to another, transferring power through the switch to the starter solenoid.

10201 & 10203

Kits **10201** / **10203**: the neutral safety/clutch switch connection is 2 wires:

PURPLE: 12-gauge wire, printed << [IGNITION SWITCH] << #919 >> [NEUTRAL SAFETY SWITCH] >>, this wire comes from the ignition switch and only has power when the switch is in the START position. This wire provides power to the neutral safety switch (NSS) from the ignition switch.

PURPLE: 12-gauge wire, printed << [ENGINE SECTION] TO STARTER SOLENOID << #919 >> [NEUTRAL SAFETY SWITCH] >>, this wire is used to provide power from the NSS to the starter solenoid "S" terminal. This wire can be seen in the [Charge / Battery Power Schematic](#) on [page 48](#) and the various ignition switch schematic found on [pages 93 – 96](#).

- Route these wires to the neutral safety switch (NSS) and connect using the pre-installed insulated terminals or by re-using your factory connector.
- If you have an automatic transmission with a column shift, the NSS is usually located at the base of the steering column, as seen in the photo with the reverse switch on [page 97](#). This same switch can be found at the base of factory console shifters.

Aftermarket Floor Shifter

- If you have a manual, the clutch switch is located at the top of the clutch pedal, much like the brake switch on the brake pedal.
- Route the wires to the reverse switch, cut to length, and strip $\frac{1}{4}$ " of insulation.
- Re-use the connector from the factory harness or the pre-installed insulated terminals. It does not matter which tab each wire connects to.

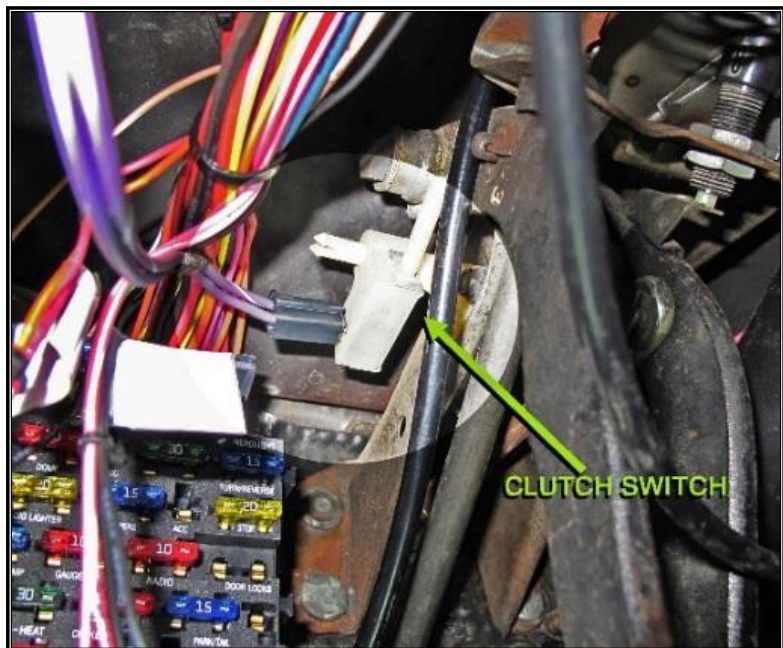

- For those with a 4L60e/4L80e transmission, a starter relay must be used (not supplied) if using a factory switch; as shown on [page 99](#). The switch is not capable of handling the amperage the solenoid requires.
- Like with the 4L60e/4L80e transmission, if you have a transmission mounted NNS that you are accessing through the engine compartment, connect these two **PURPLE** wires on the interior. Then, route the **PURPLE #919** wire to the NSS, cut to length, and connect. Use the cut-off portion of the **PURPLE #919** wire to connect the NSS to the “S” terminal on the starter solenoid.

If you do not have a neutral safety/clutch switch and do not plan on getting one, connect these wires and route the #919 wire directly to the Starter Solenoid “S” Terminal.

Painless does not recommend operating your vehicle without a neutral safety/clutch switch.

10202 & 10204

Kits [10202](#) / [10204](#): The neutral safety/clutch switch connection will involve one wire running from the starter solenoid to the ignition switch section. If you are using a NSS this wire should have been rerouted from the Engine Section to the NSS on [page 18](#), it is:

PURPLE: 12-gauge wire, printed << [ENGINE SECTION] TO STARTER SOLENOID << **#919** >> [IGNITION SWITCH] >>, This wire comes from the ignition switch and only has power when the switch is in the START position. This wire provides power to the neutral safety switch (NSS) from the ignition switch. **Once the wire is routed and cut, the excess wire is used to provide power from the NSS to the starter solenoid “S” terminal.** This wire can be seen in the [Charge / Battery Power Schematic](#) on [page 48](#) and the various ignition switch schematics found on [pages 93 – 96](#).

- If you have an automatic transmission with a column shift, the NSS is usually located at the base of the steering column, as seen in the photo with the reverse switch on [page 97](#). This same switch can be found at the base of factory console shifters.
- Route the wire to the switch, cut to length, strip $\frac{1}{4}$ ” of insulation, and connect.
- Then, strip $\frac{1}{4}$ ” of insulation from the cutoff piece of **PURPLE #919** wire and connect it to the other side of the NSS using the provided insulated terminals.
- Once connected to the switch, route the cutoff portion of **#919** to the “S” terminal on the Starter and connect. This cut-off wire will then provide power from the NSS from the starter solenoid.

Aftermarket Floor Shifter

- If you have a manual, the clutch switch is located at the top of the clutch pedal, much like the brake switch on the brake pedal (see the image on [page 100](#)).
- Route the wires to the switch, cut to length, and strip $\frac{1}{4}$ " of insulation. Also, strip $\frac{1}{4}$ " of insulation from the cutoff piece of **PURPLE #919** wire as it will connect to the switch as well.
- Re-use the connector from the factory harness or the small, insulated terminals that have been provided in the parts kit. It does not matter which tab each wire connects to. Once connected to the switch, route the cutoff portion of **#919** to the "S" terminal on the Starter and connect as mentioned on previously.
- For those with a 4L60e/4L80e transmission, a starter relay must be used (not supplied) if using a factory switch; as shown on [page 97](#). The switch is not capable of handling the amperage the solenoid requires.
- Like with the 4L60e/4L80e transmission, if you have a transmission mounted NNS that you are accessing through the engine compartment, this wire should have been left in the Engine Section. From there, route the **PURPLE #919** wire to the NSS, cut to length, and connect. Use the cut-off portion of the **PURPLE #919** wire to connect the NSS to the "S" terminal on the starter solenoid.

If you do not have a neutral safety/clutch switch and do not plan on getting one, no modification is needed. The #919 wire connects directly to the Starter Solenoid "S" Terminal from the Ignition Switch.

Painless does not recommend operating your vehicle without a neutral safety/clutch switch.

NOTES:

DRIVER DOOR SECTION

Two wires have been provided in the Driver Door Section for those with power windows and/or power locks. The Passenger Door Section will be covered on [page 120](#). The wires of the Driver Door Section are:

YELLOW: 14-gauge wire, printed [DRIVER DOOR SECTION] #913 WINDOW POWER (IGN); this wire provides a switched ignition power source for power windows from the 20-amp PWR WINDOW fuse. This wire provides power to the windows any time the ignition key is in the ACCESSORY or ON/RUN position.

YELLOW/BLACK: 14-gauge wire, printed [DRIVER DOOR SECTION] #912 DOOR LOCK POWER (BAT); this wire provides a battery power source, from the 20-amp DOOR LOCKS fuse. This wire provides constant battery power for door locks.

- For those installing aftermarket power locks, connect the **YELLOW/BLACK #912** wire to the wire or switch/relay input that requires a fused constant battery power source.
- For those installing aftermarket power windows, connect the **YELLOW #913** wire to the wire or switch/relay input that requires a fused switched ignition power source.

For those reusing the factory power lock/power window harness, locate the two connectors on the factory power lock/power window harness that connected to the accessory ports at the fuse block.

- Remove the connectors on each of the factory wires and connect them to the Painless harness.
- The factory pink/black wires connect to the power window, **YELLOW #913** wire on the Painless harness.
- The factory, orange/black wire connects to the power lock, **YELLOW/BLACK #912** wire on the Painless harness.

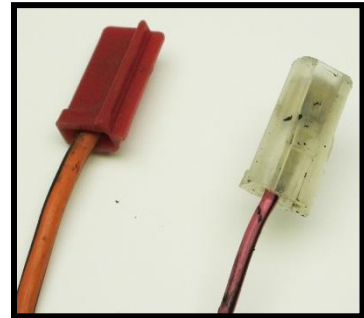

NOTES:

INSTRUMENT PANEL

The instrument panel connections of the Painless harness vary according to the gauge cluster or aftermarket gauges you are using. The wires for this connection are grouped together. These wires are:

BROWN: 18-gauge wire, printed **#930 INSTRUMENT PANEL LIGHTING**; this wire provides a power source for gauge backlighting. The **BROWN #930** wire comes directly from the headlight switch and has power anytime the headlight switch is in the Park/Taillights ON or Headlights ON position. This wire can also be seen in the [Headlight Switch & Dimmer Switch Schematic](#) on [page 75](#).

PINK: 18-gauge wire, << **[TAIL SECTION] FUEL SENDER << #939 >> FUEL GAUGE [INSTRUMENT PANEL SECTION] >>**; this wire is a ground signal from the fuel level sending unit in the fuel tank. The resistance to ground will vary on this wire according to the amount of fuel in the tank. This wire can also be seen in the [Tail Section Schematics](#) on [pages 129 & 130](#).

RED/WHITE: 18-gauge wire, printed **[INSTRUMENT PANEL SECTION] #935 GAUGE POWER (IGN)**; this wire provides a switched ignition power source to the cluster. This wire comes from the 10-amp GAUGES fuse on the fuse block. This wire has power anytime the key is in the ON/RUN position.

LT. GREEN: 18-gauge wire, printed << **[ENGINE SECTION] TO TEMP SENDER << #921 >> TO TEMP GAUGE [INSTRUMENT PANEL SECTION] >>**; this wire is a ground signal from the engine coolant temperature sending unit. The sending unit will create resistance to ground according to engine temperature. This resistance is transferred through this wire to the gauge.

PURPLE/WHITE: 18-gauge wire printed << **[ENGINE SECTION] TO COIL (-) << #923 >> TO TACHOMETER [INSTRUMENT PANEL SECTION] >>**; this wire is a ground signal from the negative side of the ignition coil. This wire can also be seen in the coil connection diagrams on [pages 45 & 46](#).

LT. BLUE/BLACK: 18-gauge wire, printed <<< **TO OIL SENDER [ENGINE SECTION A] <<< #922 >>> TO OIL GAUGE [INSTRUMENT PANEL SECTION]**, this wire is a ground signal from the oil pressure sending unit. The sending unit will create resistance to ground according to oil pressure. This resistance is transferred through this wire to the gauge.

GREEN: 18-gauge wire, printed **[INSTRUMENT PANEL SECTION] >> #936 TO HIGH BEAM INDICATOR >>**, this wire provides power to the high beam indicator when the headlight switch is in the “ON” position and the dimmer switch is in the “HIGH” position.

LT. BLUE: 18-gauge wire printed << **[ENGINE SECTION] TO OIL SENDER << #922 >> TO OIL GAUGE [INSTRUMENT PANEL SECTION] >>**; this wire provides power to the left turn indicator when the turn signal switch is in the left turn position.

BLUE: 18-gauge wire, printed **[INSTRUMENT PANEL SECTION] #938 TO RIGHT TURN INDICATOR**; this wire provides power to the right turn indicator when the turn signal switch is in the right turn position.

ORANGE/BLACK: 16-gauge wire, printed **[INSTRUMENT PANEL SECTION] #955 ACCESSORY POWER (BAT)**; this wire provides a switched ignition power source to any accessories you may have. This wire comes from the 15-amp TURN fuse on the fuse block. This wire will have power anytime the key is in the ON/RUN position.

FACTORY PRINTED CIRCUIT GAUGES

A factory schematic or your factory harness is necessary to identify the connector pinout needed for your gauges. Your factory connector and terminals must be re-used.

- Most factory, GM printed circuit gauge clusters used a 12-pin connector like the one in the diagram below. You may use a factory schematic or your factory harness to fill in the blanks on the image with the function and/or Painless wire color and circuit number for each connector location.

If you have a charge/alternator light, the **WHITE #914** wire that provides ignition power to the alternator needs to be routed to the gauge cluster, cut to length, and the cut off portion then routed from the gauge cluster out to the alternator.

If you have a brake warning light, a wire (not supplied) needs to be run from the gauge cluster to the emergency brake switch and the brake warning switch if equipped. This was most commonly an 18 ga tan wire on factory harnesses.

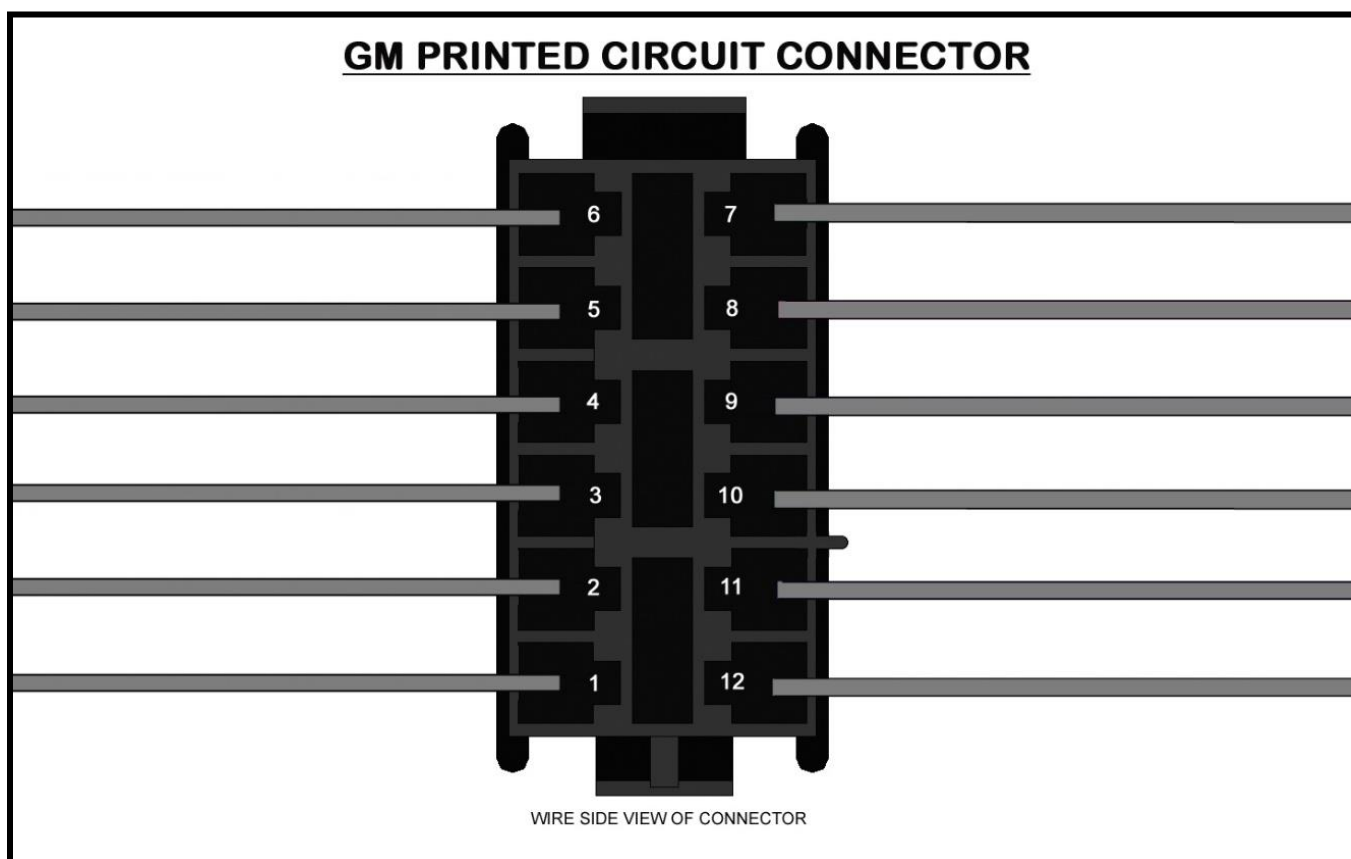

AFTERMARKET GAUGES

The following instructions will be universal due to all the different manufacturers of aftermarket gauges. Use the following instructions along with the gauge manufacturer's instructions.

Most electric aftermarket gauges require four or five wire connections:

- Gauge Power - a Switched 12-volt power source
- Gauge Ground (some gauges do not require this)
- A signal from a sensor or sending unit
- Gauge Light Power - 12-volt power source from the Gauge Lighting circuit
- Gauge Light Ground

Most mechanical aftermarket gauges only require two wires to be connected:

- Gauge Light Power- 12-volt power source from the Gauge Lighting circuit
- Gauge Light Ground

All these connections are present in the wiring Painless harness. However, it will be up to the installer to distribute the power for the gauge and the gauge lights as well as the grounds. This additional splicing will be dependent on the method the gauge wires are connected to the gauges.

There are two methods for connecting aftermarket gauges:

- Separate harness
- Hardwiring

SEPARATE HARNESS – PAINLESS #30301 & 30302

To facilitate wiring individual aftermarket gauges Painless offers, and recommends, the use of **Painless part #30301** (**#30302** if using an electric speedometer). This is a universal gauge cluster harness that has all the splicing and termination pre-installed for these types of applications. This harness also offers you the benefit of having an inline connector instead of hardwiring the chassis harness directly to the gauges.

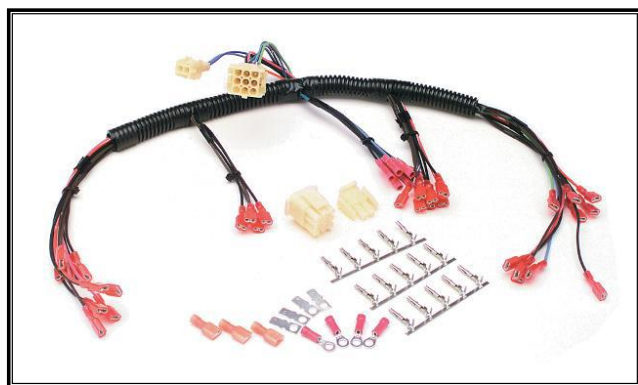

- Using the terminals and connector found in the **30301** or **30302** kits, install the wires of the Painless chassis harness according to the diagram below. Use the numbers on the connectors as well as the circled reference points in the diagram for the proper cavity location. A gauge light ground will not be used.

30301 or 30302 CONNECTOR PINOUT

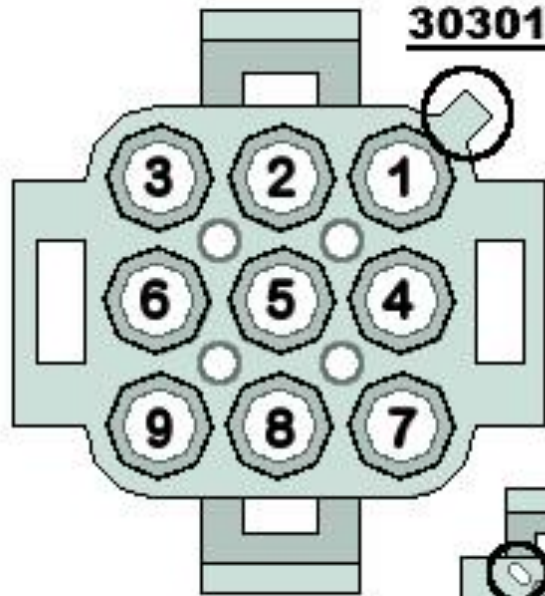

1. #921 ENGINE TEMP SIGNAL / TEST
2. #922 OIL PRESSURE SIGNAL
3. #936 HIGH BEAM INDICATOR POWER
4. #923 TACH SIGNAL
5. #930 GAUGE LIGHT POWER
6. #935 GAUGE POWER
7. INSTRUMENT CLUSTER GROUND
- (customer supplied)
8. #939 FUEL LEVEL SIGNAL
9. empty

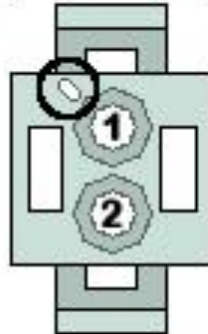

1. #938 RIGHT TURN INDICATOR
2. #937 LEFT TURN INDICATOR

HARDWIRING:

For those who choose to wire aftermarket gauges with just the wires found in the Painless chassis harness, and not purchase an additional gauge harness, the following steps will walk you through the process of distributing power and ground as well as connecting the sender wires. The following diagrams only show temp, oil pressure, volt, and fuel level gauges. Power, ground, and sender wires connect in the same manner to speedometers and tachometers.

Power to the gauges comes from the **RED/WHITE #935** wire, and it needs to be connected to the "I" or "12v" post on each gauge. The power wire can be connected in one of two ways:

#1) Splicing- This is when you connect multiple wires to a single wire to distribute power/ground to multiple components. In this case, splices on the **RED/WHITE #935** wire are running wires to several gauges to provide power to each gauge.

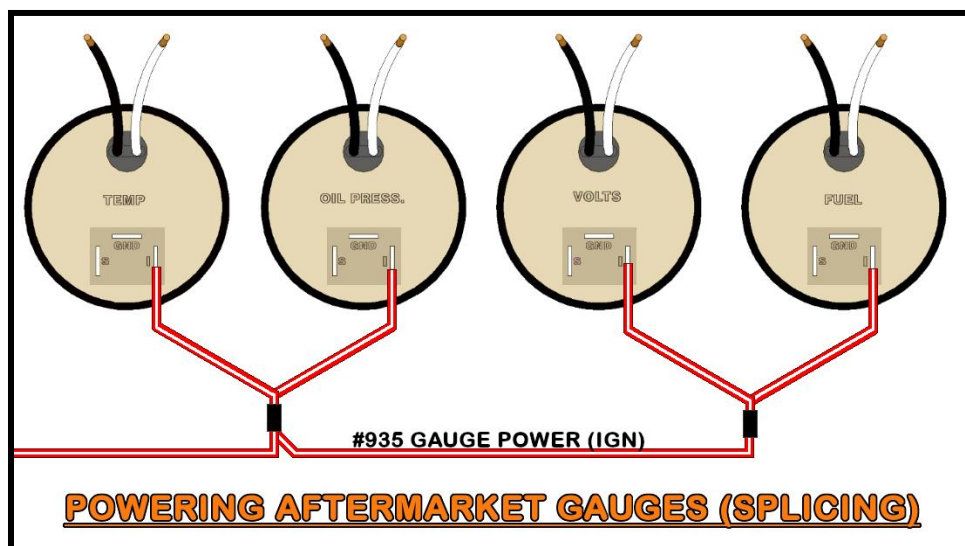

#2) Chaining or Jumpering- Run the **RED/WHITE #935** wire to a power post. **Before terminating the wire** with the proper terminal, insert another wire into the terminal and crimp. You now have 2 wires in 1 terminal. This additional wire then routes to the next gauge's power post. Before terminating that wire with the proper terminal, insert another wire into the terminal; and so on.

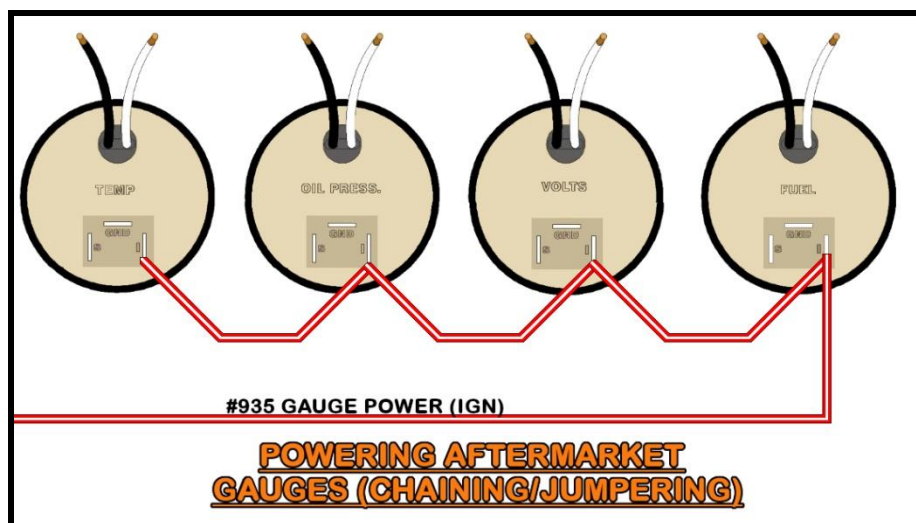

Grounds need to be supplied to the gauge lights and any ground tab on the gauges. The installer needs to run their own ground circuit for gauge connections. To make these ground connections you can splice from the installer provided ground wires to all the gauges or chain/jumper it all together. Both methods can be seen in the following two drawings:

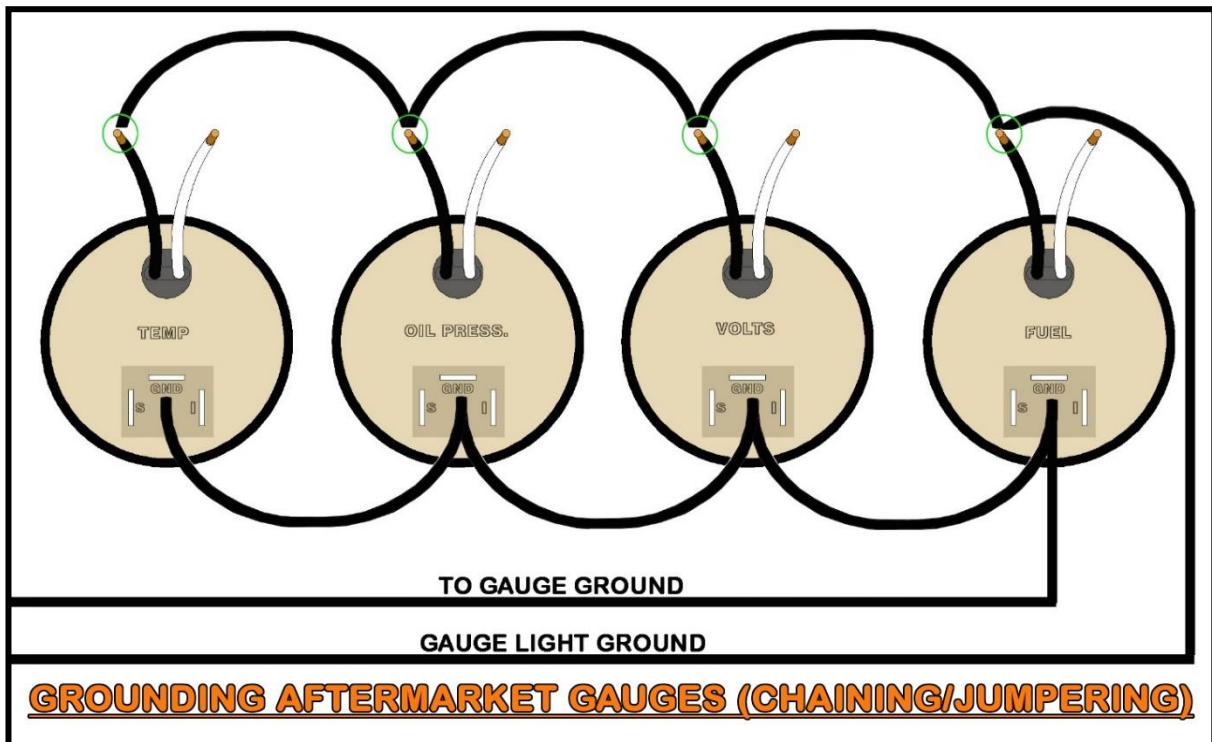
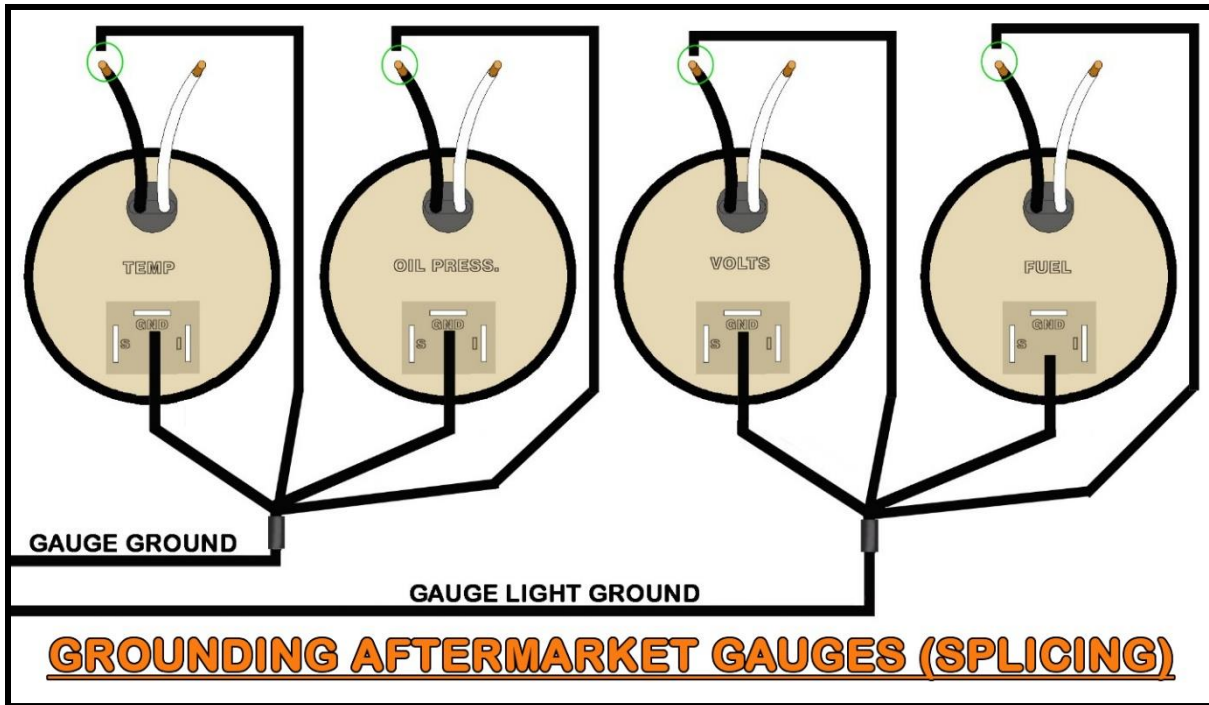

Gauge light power is supported by the **BROWN #930** wire. This wire connects to one of the leads for the gauge light or the gauge light tab found on gauges with LED backlighting. To make these connections you can splice from this **BROWN #930** wire to all the gauges or chain/jumper it all together.

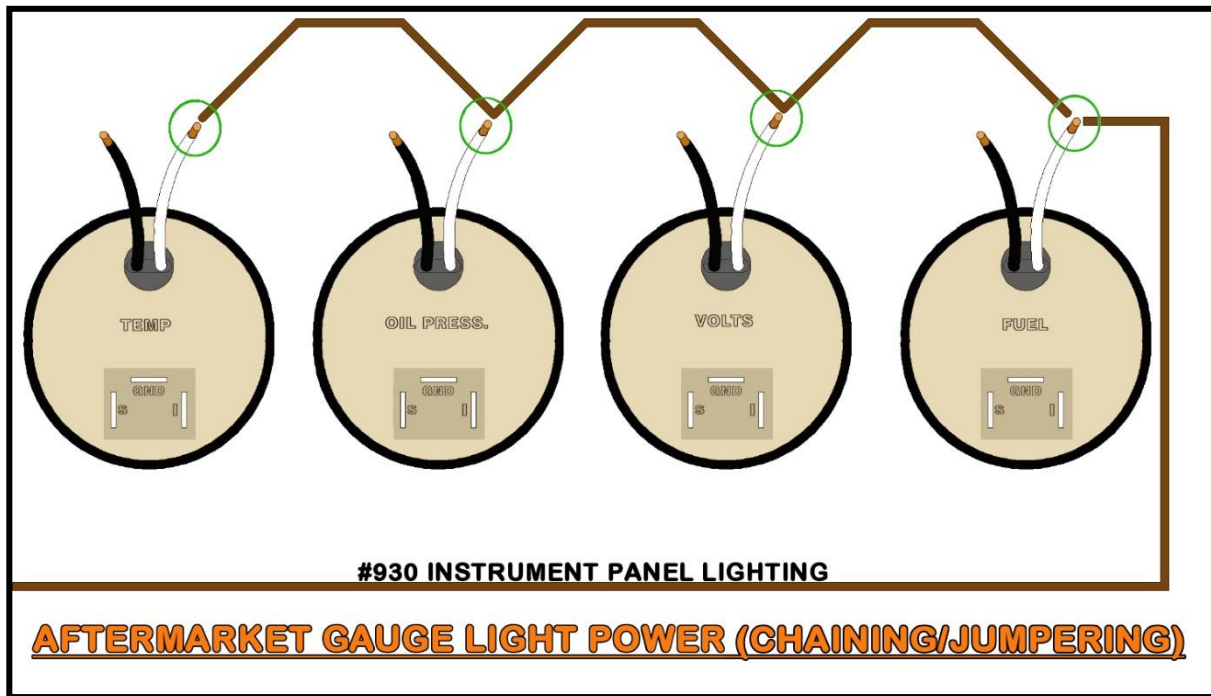
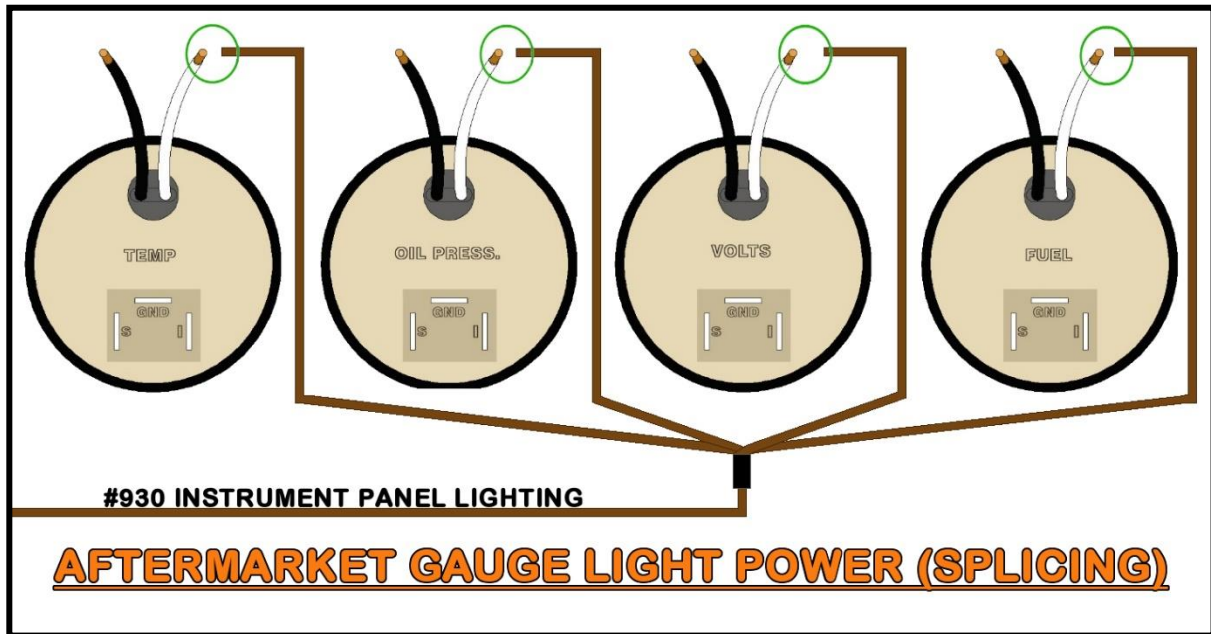

The last connections that need to be made are the sending unit wires or signal wires. These are the wires which come from the temperature sending unit, oil pressure sending unit, and fuel level sending unit. Not shown in the diagram, but also provided in the Painless chassis harness is the **BROWN #923 TACHOMETER SIGNAL** wire.

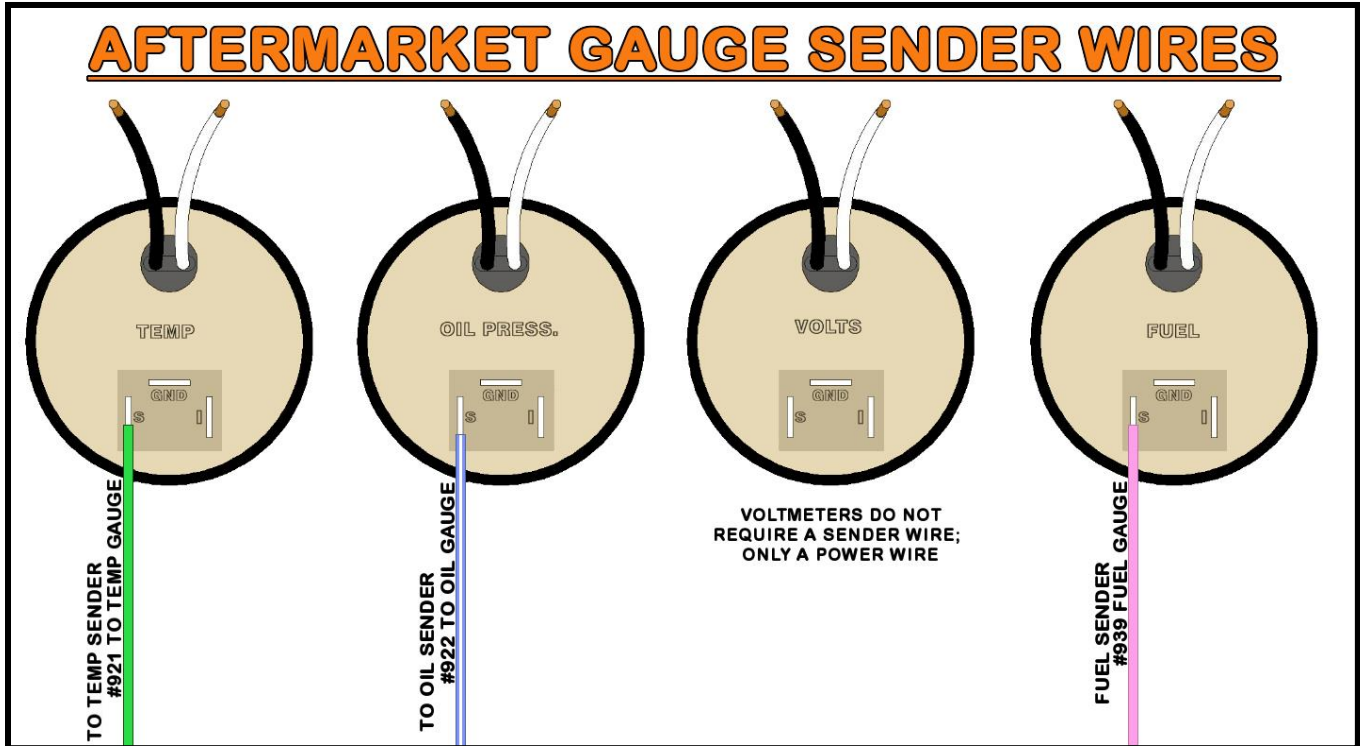

NOTES:

RADIO & ACCESSORIES

This Painless harness includes provisions for several accessory components that may or may not be used on your install. These accessory wires include wiper power, which should have already been connected. Below, you will find information about each of these accessories and the wires provided in this harness to connect them.

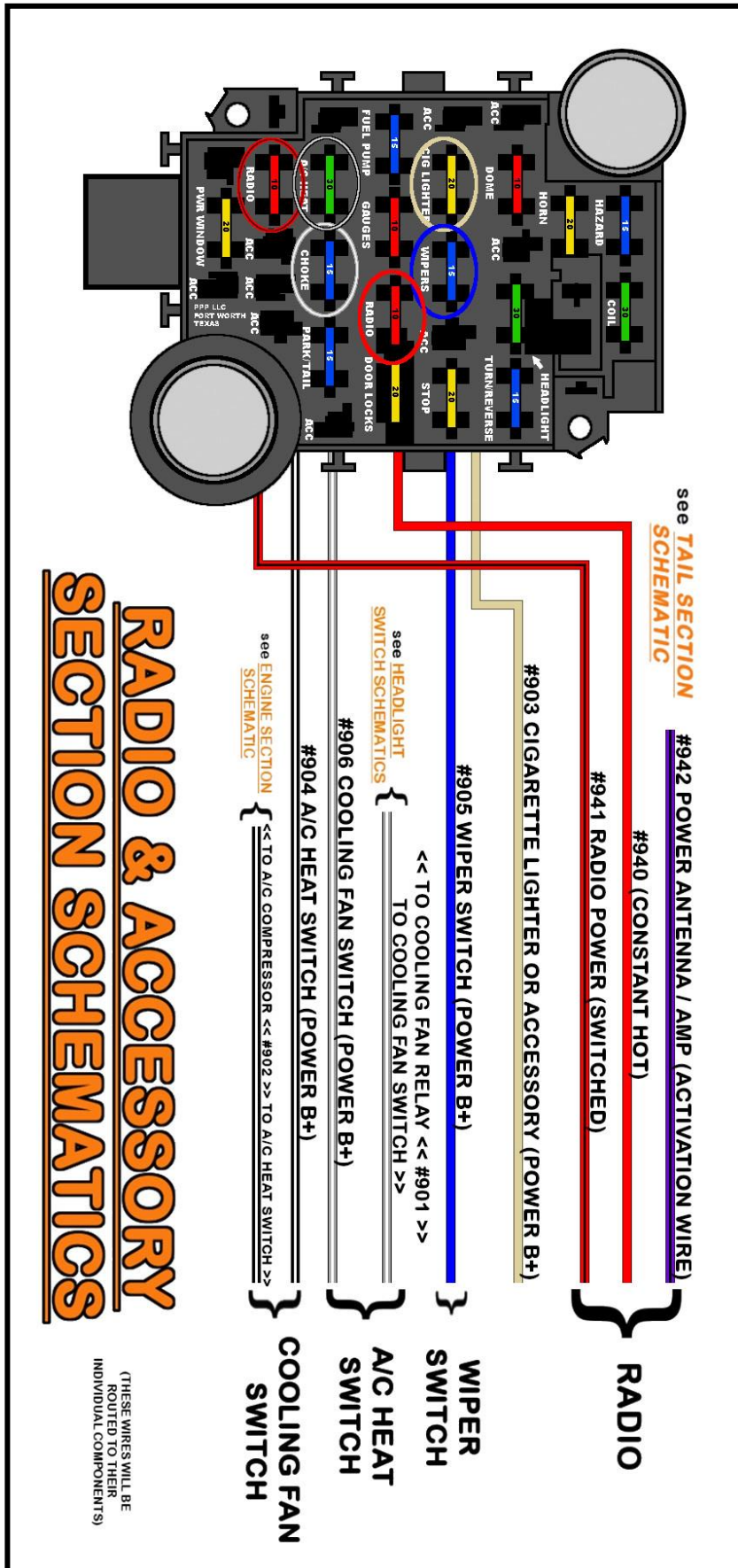

RADIO

The radio connection on the Painless harness is set up for a universal application. This means the two power wire colors used by Painless reflect the colors most aftermarket companies use on radios/head units manufactured today. The Painless harness includes 3 wires dedicated to a connection to the radio. They are:

RED: 18-gauge wire, printed **[RADIO SECTION] #940 (CONSTANT HOT)**; this wire provides the radio a battery power source that allows the time and radio presets to remain every time the ignition is turned off. This wire comes from the 10-amp RADIO fuse and can be seen in the [Radio & Accessory Schematic](#) on [page 113](#).

RED/BLACK: 18-gauge wire, printed **[RADIO SECTION] #941 RADIO POWER (SWITCHED)**; this wire provides the radio with ignition-switched power for operation. This wire has power when the ignition switch is in the ACCESSORY and ON/RUN positions. This wire comes from the 10-amp RADIO fuse of the fuse block and can be seen in the [Radio & Accessory Schematic](#) on [page 113](#).

PURPLE/BLACK: 18-gauge wire, printed **<< [RADIO SECTION] << #942 >> POWER ANTENNA / AMP (ACTIVATION WIRE) [TAIL SECTION] >>**; this wire provides a power from the radio to the power antenna and/or amplifier. This is a lay-in wire and can be removed if you are not using a power antenna or amplifier.

If you are wanting to wire in a radio dim/backlight, then you will need to splice into the **BROWN #930 INSTRUMENT PANEL LIGHTING** wire. This wire will provide a power signal to the radio to dim the backlighting/display during low light conditions. On older radios, this power source will illuminate the backlighting. This wire will have power anytime the headlight switch is in the Park/Taillights ON or Headlights ON position. This wire/splice can be seen in the [Headlight Switch Schematic](#) on [page 75](#).

If you have a gear indicator light on a floor mount shifter, you will need to link a wire from the **#930** wire at the radio to one side of the gear indicator light. Linking or Chaining was explained on [page 108](#) in the Instrument Panel instructions. Linking from the **#930** wire will provide power to the gear indicator light. The ground side of the gear indicator light can be connected directly to a clean chassis ground source, either from a wire or directly to the floor pan/transmission tunnel.

- If you are using an aftermarket radio, refer to the manufacturer's installation guide for proper connection. Splices and bullet terminals have been provided in the parts kit.
- If you are using a factory radio, a factory schematic for the vehicle it came out of will be needed to identify the connections to the radio.

Many older radios require one power source, Painless recommends connecting the **RED/BLACK #941** to the radio in these circumstances so that the radio will only operate when the ignition switch is in the ACCESSORY or ON/RUN position. This will prevent the radio from draining the battery if it is accidentally left on.

- **You must supply a ground for the radio.**

ACCESSORY SECTION

The Accessory Section of the Painless harness consists of 6 wires for various accessory applications. Locations of all these components vary from vehicle to vehicle, so no specific routing instructions can be given.

Wiper Switch

BLUE: 16-gauge wire, printed **[ACC. SECTION B+] #905 WIPER SWITCH (POWER B+)**, this wire provides ignition switched power to the wiper motor or switch depending on your set-up and comes from the 15-amp WIPER fuse.

- This wire should have been rerouted to either the wiper motor or wiper switch on [page 17](#). Cut to length and connect.
- Please note, this harness does not include any additional wires for vehicles with wipers due to the numerous different systems: factory and aftermarket.

A/C – Heat Switch

BLACK/WHITE: 14-gauge wire, printed, **[ACC. SECTION B+] #904 A/C HEAT SWITCH (POWER B+)**, this wire provides a switched ignition power source for a factory or aftermarket A/C system and comes from the 30-amp AC/HEAT fuse.

BLACK/WHITE: 14-gauge wire, printed << **[ENGINE SECTION] TO A/C COMPRESSOR << #902 >> TO A/C HEAT SWITCH [ACC. SECTION SWITCHES]** >>, this wire is intended to provide power to the A/C compressor clutch. This wire comes from the A/C switch inside the vehicle to the binary or trinary safety switch and then to the compressor.

- Install mating insulated terminals onto the **#904** and to the wire of your aftermarket A/C system harness that requires a fused, switched ignition, 12v source.

Factory Heater or A/C Harness

This harness does not include any wiring for the factory heat or air conditioning or wiring to the blower motor and blower motor resistor; **your original harness or a reproduction of the original harness must be used**. The Painless harness plugs directly into a factory/reproduction harness without any modifications.

- Locate the inline connector on the factory heat or A/C harness, it will be a single-pin connector on a wire several inches away from the blower switch connection. This connector is the power feed to the factory harness. Connect the **BLACK/WHITE #904** power wire to this wire on the air conditioning harness by re-using the factory connector from your old harness or a splice from the parts kit.



Fan Relay Activation Using #906 Accessory Power (Ign.)

GREY/WHITE: 18-gauge wire, printed [ACC. SEC. B+] #906 COOLING FAN SWITCH (POWER B+), this wire provides a switched Ignition power source for an accessory not exceeding 5 amps. In most cases, this wire is used to provide a cooling fan relay a switched 12v source activation. **DO NOT POWER A COOLING FAN WITH THIS WIRE.** If the #906 wire will be used to power some other accessory, re-route the #906 in the harness to wherever the accessory is located.

GREY/WHITE: 18-gauge wire, printed << [FRONT LIGHT SECTION] TO COOLING FAN RELAY << #901 >> TO COOLING FAN SWITCH [ACC. SECTION SWITCHES] >>; This wire will only have power if it is connected to the **GREY/WHITE** #906 wire. This wire can be used for the activation of the relay coil only and **MUST NOT** be used to directly power a cooling fan.

The remaining relay wiring, circuit breaker, relay, and temperature switches seen in the diagram are **NOT** included in this kit. Painless does offer numerous relay kits that do include these parts, like [Painless #'s 30101, 30102, or 30103](#).

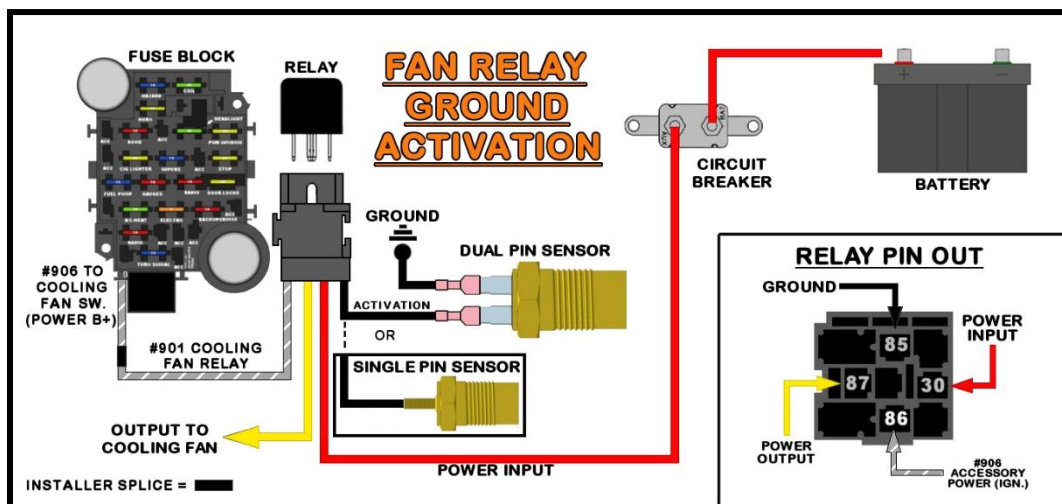
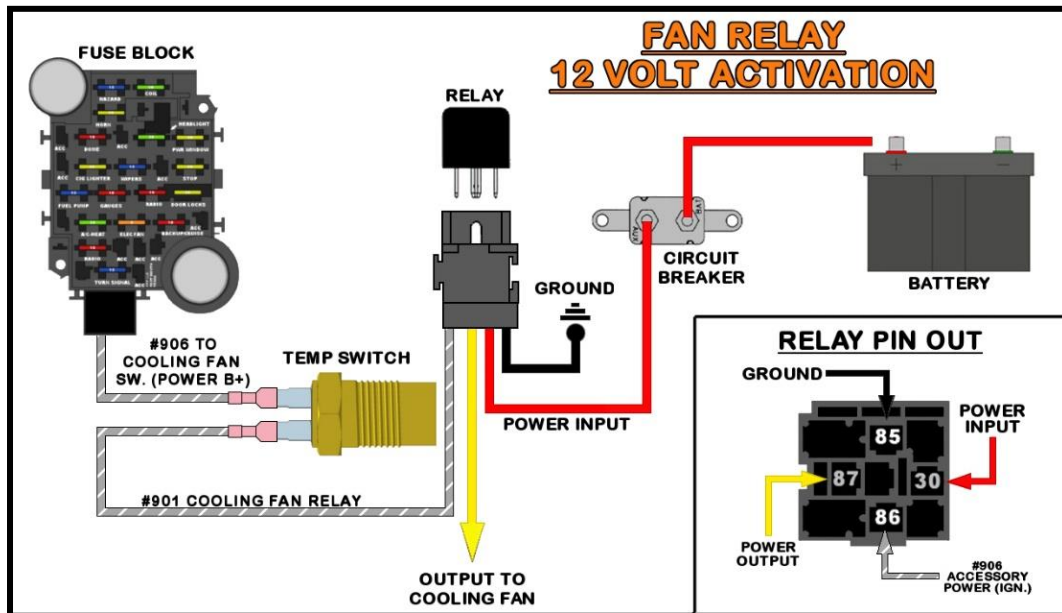

Cigarette Lighter/Power Port

The Cigarette Lighter/Power Port connection on the Painless harness is set up for a universal application since most sockets have been replaced by aftermarket sockets. Typically, the cigarette lighter is more commonly used as a power port to charge and run electronic components requiring a 12vDC power source.

TAN: 14-gauge wire, printed, [ACC. SECTION B+] **#903 CIGARETTE LIGHTER OR ACCESSORY (POWER B+)**; this wire comes from the 20-amp CIG LIGHTER fuse and provides a battery power source to a cigarette light/power port



- Route the **TAN #903** wire to the cigarette lighter/power port.
- Cut the wire to length and connect according to one of the following options (see the clock notation below before doing any termination):
 - Ring terminals and bullet/socket/spade style terminals are provided in the parts kit to connect universal aftermarket lighters/power ports. Universal Lighter socket part **#56458**, seen in the photo, can be found at most local parts stores. A ground wire is needed.
 - For those with a factory socket, you can cut the connector from your factory harness. Leave 3" or 4" of wire to create a pigtail and splice it to the **TAN #903** wire on the Painless harness. Splices have been provided in the parts kit.

If You Have a Clock

- Retain the cutoff portion of the **TAN #903** wire and double it with the wire connecting to the cigarette lighter/power port.
- Route this wire to the clock and connect.

PASSENGER DOOR SECTION

Two wires have been provided in the Passenger Door Section for those with power windows and/or power locks. The driver side was covered in Driver Door Section on [page 103](#). The wires of the Passenger Door Section are:

YELLOW: 14-gauge wire, printed **[PASS. DOOR SECTION] #911 WINDOW POWER (IGN)**; this wire provides a switched ignition power source for power windows from the 20-amp PWR WINDOW fuse. This wire provides power to the windows any time the ignition key is in the ACCESSORY or ON/RUN position.

YELLOW/BLACK: 14-gauge wire, printed **[PASS. DOOR SECTION] #910 DOOR LOCK POWER (BAT)**; this wire provides a battery power source, from the 20-amp DOOR LOCKS fuse. This wire provides constant battery power for door locks.

- For those installing aftermarket power locks, connect the **YELLOW/BLACK #910** wire to the wire or switch/relay input that requires a fused constant battery power source.
- For those installing aftermarket power windows, connect the **YELLOW #911** wire to the wire or switch/relay input that requires a fused switched ignition power source.

For those reusing the factory power lock/power window harness, locate the two connectors on the factory power lock/power window harness that connected to the accessory ports at the fuse block.

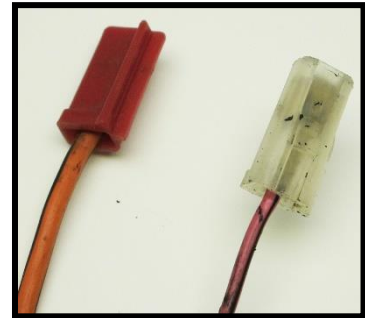

- Remove the connectors on each of the factory wires and connect them to the Painless harness.
- The factory pink/black wires connect to the power window, **YELLOW #911** wire on the Painless harness.
- The factory, orange/black wire connects to the power lock, **YELLOW/BLACK #910** wire on the Painless harness.

NOTES:

TAIL SECTION

The **Tail Section** wires are the last group to be connected. This group of wires connect to things like the right & left turn signals, taillights, reverse lights, license plate light, dome light, trunk light, power antenna, and fuel level sending unit. All the wires found in the **Tail Section** can be seen in the schematics found on [pages 129 & 130](#).

- Route the wires with the print reading “TAIL SECTION” to the rear of the vehicle. Make sure to avoid pinch points around door/trunk hinges and moving parts like window regulators.

DOME LIGHT

The dome light has constant battery power applied to it. This light is ground activated by the door jamb switches and by turning the headlight switch to the DOME LIGHT ON position. These wires can be seen in the tail section schematics on [pages 129 & 130](#), they are:

WHITE: 18-gauge wire, printed **[TAIL SECTION] #945 DOME LIGHT POWER (BAT)**; this power wire comes from the 10-amp DOME fuse on the fuse block; this fuse has battery power and is “hot” at all times.

BLACK: 18-gauge wire, printed **<< [TAIL SECTION] DOME LIGHT GROUND << #961 >> DOME/COURTESY LIGHT ACTIVATION [HEADLIGHT SWITCH] >>**; this wire is the ground wire that activates the dome light. When this wire is grounded it completes the voltage path causing the light to illuminate. This ground will come from either a door jamb switch or the headlight switch.

In most cases, these wires will attach to the factory dome light wires. The factory wires coming from the dome light can usually be seen in the trunk, on the driver’s side, near the trunk hinge. Connect the Painless harness to the factory pigtail coming from the dome light.

- If you do not have a factory pigtail, there has been ample length supplied to allow routing of the **BLACK #961** and the **WHITE #945** to the dome light fixture. In most cases, this will require the headliner of the vehicle to be removed. You will need new terminals, though, to connect to your existing dome light fixture.

TRUNK LIGHT

The trunk light is the next connection that needs to be made. If you do not have a trunk light, **#958** can be used to power an accessory requiring a switched 12v power source. This wire is:

GREEN/BLACK: 18-gauge wire, printed **[TAIL SECTION] #946 TRUNK LIGHT / ACC. POWER (BAT)**; this power wire comes from the 10-amp DOME fuse on the fuse block; this fuse has battery power and is “hot” at all times.

- In most cases, the trunk light will have a socket/bullet terminal connection. Insulated terminals have been provided in the parts kit to connect to these types of plate lights.
- Your factory light socket must be re-used. Splice the Painless harness wires to the factory wires coming from your socket.

POWER ANTENNA

For those with a power antenna, Painless provides a single power wire that runs from the radio to a rear-mounted power antenna. If your power antenna is in the front of the vehicle, this wire should have been re-routed with the [Instrument Panel Section](#) on [page 18](#).

PURPLE/BLACK: 18-gauge wire, printed **<< [RADIO SECTION] << #942 >> POWER ANTENNA / AMP (ACTIVATION WIRE) [TAIL SECTION] >>**; this wire provides a power from the radio to the power antenna and/or amplifier. This is a lay-in wire and can be removed if you are not using a power antenna or amplifier.

- Route the **PURPLE/BLACK #942** power wire to the antenna and/or amplifier and connect.
- Ground (if needed) is not supplied.
- It may be necessary to refer to factory schematics, or if you are using an aftermarket antenna, the manufacturer’s installation instructions.
- If you are using both a power antenna and an amplifier, simply double up the cut-off portion of the **#942** wire at the first connection (amp or antenna whichever is closest) and chain to the second item. Chaining is covered on [page 108](#).

LEFT SIDE MARKER LIGHT

The left side marker light is the next connection. The marker light is activated by a power source coming from the headlight switch. This light illuminates any time the headlight switch is in the *PARK* or *ON* position.

BROWN: 16-gauge wire, printed [TAIL SECTION] #929 TAILLIGHT, this is a power wire for the left taillight, but also provides power for the rear park or marker light. This wire has power anytime the headlight switch is in the Park/Taillights ON or Headlights ON position. This wire, along with all the other wires and splices it is associated with, can be seen in the tail section schematics on [pages 129 & 130](#).

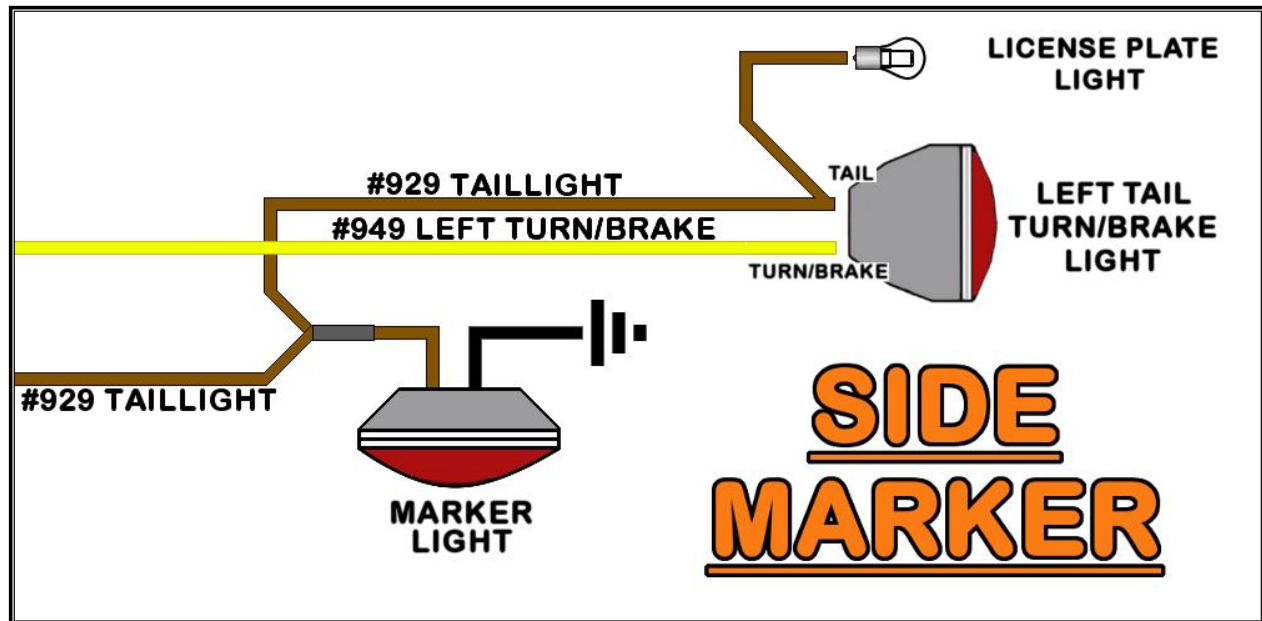

- This wire also provides power to the left taillight and license plate light as well. All three lights will need to be hardwired together using the chaining or jumper method discussed on [page 108](#).
- Route the taillight wire to the marker light and cut to length.
- Strip $\frac{1}{4}$ " of wire from the wires of the Painless harness and from the wires on the socket.
- Splice the wire of the Painless harness and the excess wire you just cut off with one of the wires on the socket.
- Then, provide a ground. It does not matter where which wire goes.
- Keep the remainder of the wire will be routed to the taillight and then license plate light.

LEFT TURN / BRAKE LIGHTS

Connection to the turn signal/brake lights depend on if your vehicle has integrated or separate turn/brake signals; both are explained on [page 82](#).

To begin making connections to the turn/brake lights, locate the wires in the tail section dedicated to these functions, they are:

YELLOW: 16-gauge wire, printed **[TAIL SECTION] #949 LEFT TURN / BRAKE**; this wire provides power to the left turn signal. This wire has power anytime the turn signal is in the down/left position and the ignition switch is in the *ON/RUN* position. For vehicles with integrated turn/brake signals, this wire is also the brake light power. The wire has power anytime the brake pedal is pressed or anytime the hazard switch is activated. This wire can be seen in tail section schematics on [pages 129 & 130](#).

ORANGE: 18-gauge wire, printed **[TAIL SECTION] #950 BRAKE LIGHT POWER (SEPARATE/3RD BRAKE ONLY)**; this wire provides power to the brake lights on vehicles with separate turn/brake lights, or a third brake light, and has power anytime the brake pedal is pressed, or the hazard switch is activated. This wire can be seen in the [Tail Section Schematics](#) on [pages 129 & 130](#).

Notice there is only one separate brake light wire going to the Tail Section.

Since Painless has no idea if this wire will be needed in your application, and since it is not used in most applications, we only provide one wire to prevent additional unused power wires to be taped up in the harness. If separate turn brake sockets are used, **it will be up to you to splice or link this brake light power to all brake lights.**

If you have integrated turn/brake lights and no 3rd brake light, install an insulated terminal on this ORANGE #950 wire and tape it up into the harness, this wire will not be used.

Your factory turn signal sockets must be re-used. Splice the Painless harness wires to the factory wires coming from your sockets.

- Loosely route the **YELLOW #949** turn signal wire to the turn signal. On integrated brake/ turn housings/assemblies with a dual filament bulb, this will be the brighter filament. If you have separate turn/brake lights this will connect to the socket with the yellow lens.
- If you have separate turn/brake lights, route the **ORANGE #950** brake light wire to the closest brake light as well. On housings/assemblies with a dual filament bulb, this will be the brighter filament.
- If your housing requires a ground source, ground wires need to be connected at this time.
- Cut the wires to length and connect to the appropriate contact/wire in the housings/assemblies. Consult the manufacturer's instructions if you are using aftermarket assemblies.

LEFT TAILLIGHT

In most cases, your rear exterior lights have at least one housing/assembly with a dual filament bulb. The taillight connections attach to the dimmest filament(s) of this type of housing/assembly. One wire is provided in the tail section for these connections, it is:

BROWN: 16-gauge wires, printed **[TAIL SECTION] #929 TAILLIGHT**; this wire provides the left taillight power. This wire receives power from the headlight switch and has power anytime the headlight switch is pulled into the PARK/TAILLIGHT ON and HEADLIGHT ON positions. This wire can be seen in the [Tail Section Schematics](#) on [pages 129 & 130](#).

- Your factory taillight sockets must be re-used.
- Loosely route the **BROWN #929** taillight wire to the taillight. On housings/assemblies with a dual filament bulb, this will be the dimmer filament.
- Cut the wire to length and connect it and the cutoff portion to the appropriate contact on the housing/assembly. Consult the manufacturer's instructions if you are using aftermarket assemblies.
- Route the cutoff portion to the license plate light.

LEFT REVERSE LIGHT

One wire is provided in the tail section for reverse light connections, it is:

LT. GREEN: 18-gauge wire, printed **[TAIL SECTION] #956 REVERSE LIGHT**; this wire provides power to the reverse or back up lights. This wire receives power from the reverse switch and has power anytime the shifter is in the "REVERSE" position with the ignition switch in the "ON/RUN" position.

- Your factory, reverse-light sockets must be re-used.
- Loosely route the **#956** reverse light wire to the reverse light.
- Cut the wires to length and connect them to the appropriate contact on the housings/assemblies. Consult the manufacturer's instructions if you are using aftermarket assemblies.
- **If your vehicle does not have reverse lights, tape them up into the harness, these wires will not be used.** The wires only have power if they are connected to a reverse switch. The wires can also be removed from the harness if it is not being used.

FUEL SECTION

Fuel Sender

Painless provides two wires for the fuel section: a connection from the fuel level sender to the gauge and switched, 12v power for a low-pressure, in-line, electric fuel pump.

The fuel level sending unit sends a ground signal to the fuel level gauge. The float inside the tank moves up and down with the level of fuel in the tank. This raising and lowering of the fuel level moves an arm/contact across a resistor of the sending unit. This sends a resisted signal to the fuel level gauge. The amount of resistance the gauge sees is evident based on the reading of the gauge. For the fuel gauge to work properly, the fuel level sending unit operating range must match the gauges operating range. See the table below for the most common fuel level sender resistance.

MAKE	YEARS	Ohms Empty	Ohms Full
GMC	UP TO '64	0	30
GMC	'65 - '97	0	90
GMC	98 AND LATER	40	250
FORD	UP TO '87	73	10
FORD	'87 AND LATER	16	158
MOPAR	UP TO '86	73	10
TOYOTA/NISSAN	'85 AND LATER	90	0
VDO	-	10	180
STEWART-WARNER, CLASSIC INSTRUMENTS, & AUTOMETER	-	240	33

PINK: 18-gauge wire, << [TAIL SECTION] FUEL SENDER << #939 >> FUEL GAUGE [INSTRUMENT PANEL SECTION] >>; this wire sends the ground signal from the fuel level sending unit to the fuel level gauge.

- Route the **PINK #939** wire to the fuel level sending unit and connect.

***Note: If a hole must be drilled in the trunk pan, be sure to not puncture the fuel tank.** Also, before a hole is drilled, make sure there is no other way to get the **#939** wire to the fuel sender.

- **The sending unit must be grounded to work properly;** Painless does not offer a wire specifically for this. Some sending units have a tab for a ground connection while others may rely on the sending unit mounting. If your sending unit has a ground tab, run a wire from a clean chassis ground source to this tab.

If you do not have a ground tab, run a ground wire from a clean chassis ground source to one of the mounting bolts of the sending unit. Do not rely on a ground through the mounting of the sending unit to the tank.

Fuel Pump

YELLOW/WHITE: 16-gauge wire, printed [TAIL SECTION] #947 ELECTRIC FUEL PUMP POWER (BAT); this wire provides a power source to an electric fuel pump. This wire comes from the 15-amp, FUEL PUMP fuse on the fuse block and only has power when the ignition switch is in the ON/RUN position.

- If a mechanical pump is being used, this wire can be used to power any component needing a switched ignition power source, not exceeding 15 amps.
- **DO NOT USE THIS WIRE FOR AN EFI PUMP.** An EFI fuel pump requires a fuel pump relay and not this wire. This is only for a low-pressure pump on a carbureted system.
- Once in the trunk area, route this #947 out of the hole in the tail panel that the fuel sending unit wire exits the trunk from.
- Connect the #947 wire to the power or + post/tab/wire of the fuel pump.
- At this time, you will need to provide a ground wire. This harness does not provide a ground wire for an electric fuel pump, but a ground can be easily connected using insulated terminals from the parts kit and a length of scrap wire created during a previous connection. Simply connect the ground or - post/tab/wire of the fuel pump to one of the mounting bolts holding the fuel pump to the frame/body.

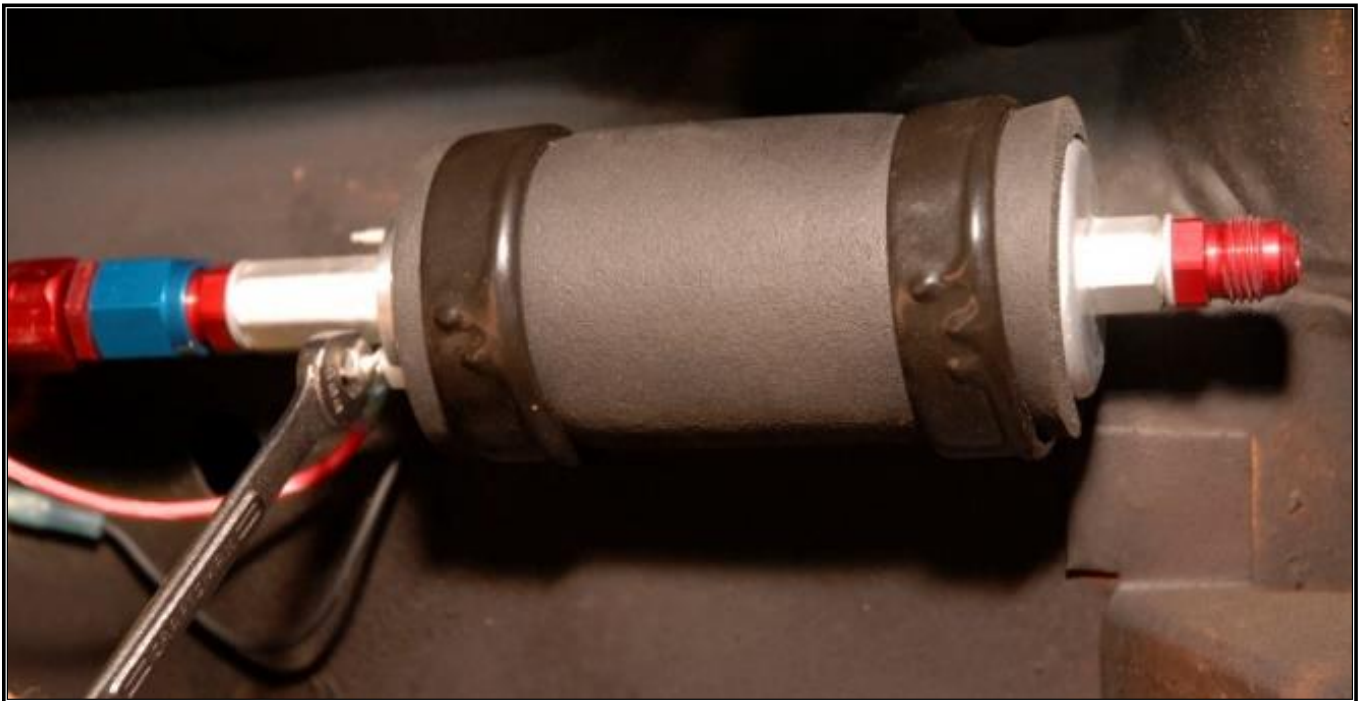

LICENSE PLATE LIGHT

The plate light is the next connection that needs to be made. This light is tied to the rear marker lights and taillights and will illuminate the license plate when the headlight switch is in the park light “ON” or headlight “ON” positions.

BROWN: 18-gauge wire, printed **[TAIL SECTION] #929 TAILLIGHT**; this is a power wire for the left taillight, but also provides power for the license plate light function. This wire has power anytime the headlight switch is in the park light ON or headlight ON positions. This wire, along with all the other wires and splice it is associated with, can be seen in the tail section schematics on [pages 129 & 130](#).

- In most cases, your license plate light will have a socket/bullet terminal connection. Insulated terminals have been provided in the parts kit to connect to these types of plate lights. You can cover the insulated terminal with heat shrink once connected to clean up the look of this connection since colored insulated terminals can often look out of place.
- Your factory light socket must be re-used. Splice the Painless harness wires to the factory wires coming from your socket.

RIGHT TURN/ BRAKE/ REVERSE/ MARKER LIGHTS

The connections mentioned above all connect in the same manner as those on the left/driver side. The only difference you will find is the turn signal wire for the right turn signal is a different color than the one used for the left turn signal. The right turn signal will be:

GREEN: 16-gauge wire, printed **[TAIL SECTION] #948 RIGHT TURN / BRAKE**; this wire provides power to the right turn signal. This wire has power anytime the turn signal is in the up/right position and the ignition switch is in the *ON/RUN* position. For vehicles with integrated turn/brake signals, this wire is also the brake light power and has power anytime the brake pedal is pressed, or the hazard switch is activated. This wire can be seen in the tail section schematics on [pages 129 & 130](#).

TAIL SECTION SCHEMATIC w/ INTEGRATED TURN/BRAKE

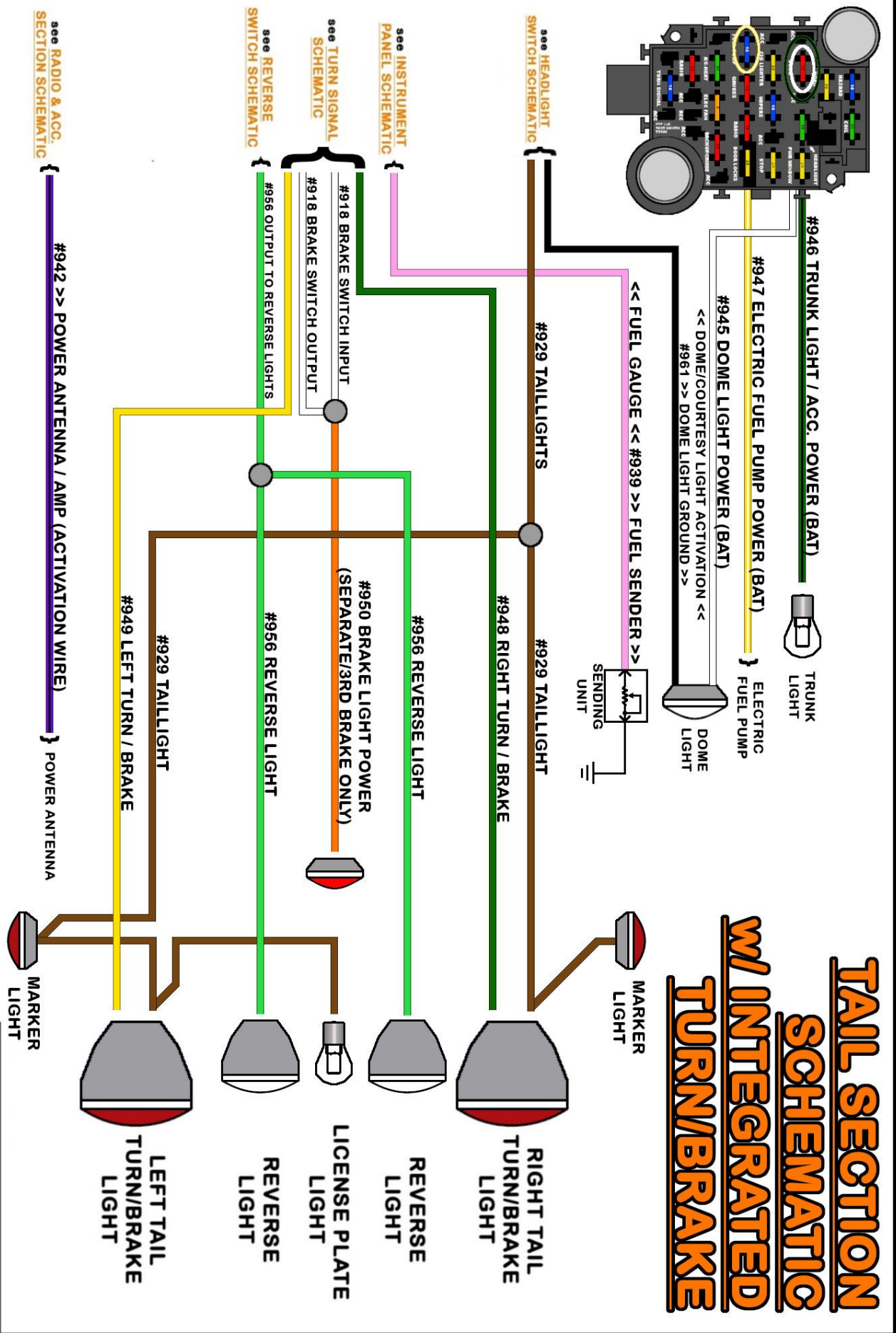

TAIL SECTION SCHEMATIC WI SEPERATE TURN/BRAKE

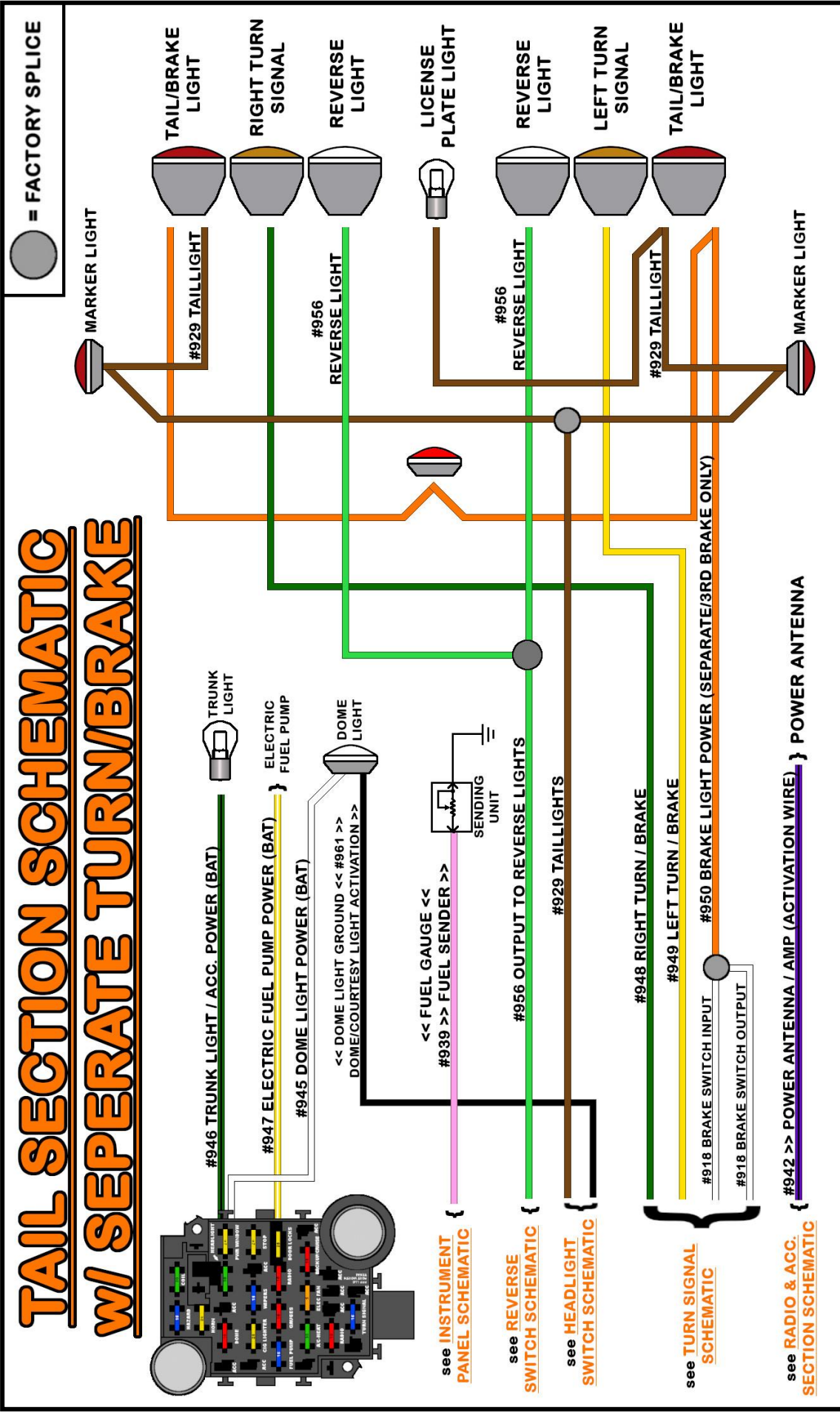

FINAL STEPS

- Connect the positive (+) battery cable to the positive side of the battery and make sure the other end of this cable is connected to the B+ side of the starter solenoid.
- At this point connect the **RED #915** from the MIDI fuse to the positive side of the battery, either through the starter lug or the battery lug.
- Attach the vehicle's negative (ground) battery cable to the battery.
- INDIVIDUALLY turn on each light, ignition, wiper circuit, etc., and check for proper operation. Turn off each component before testing another. This will help narrow down any issues that may arise.
- Once testing is complete, re-install any panels, lens, or other parts that were removed during the harness installation. You are now finished installing this Painless Harness, congratulations!

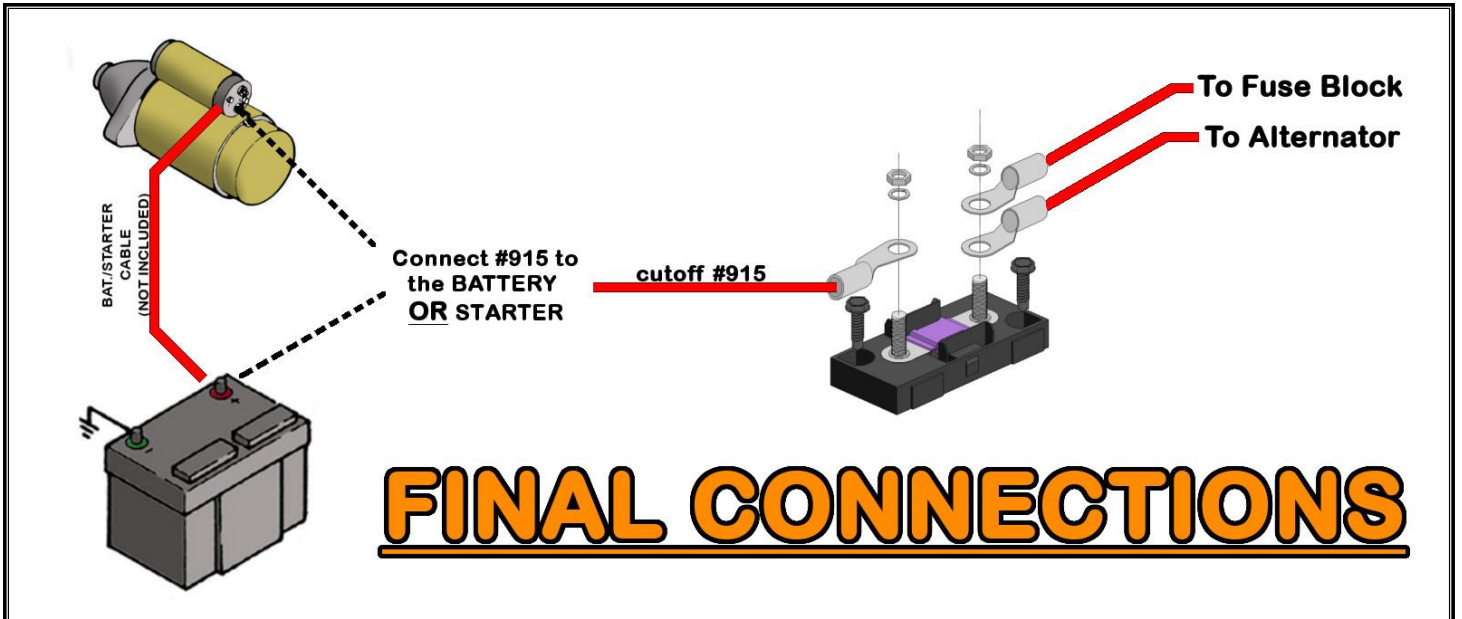

Painless Performance Products, LLC Limited Warranty and Return Policy

Chassis harnesses, fuel injection harnesses, and Trail Rocker units are covered under a lifetime warranty.

All other products manufactured and/or sold by Painless Performance are warranted to the original purchaser to be free from defects in material and workmanship under normal use. Painless Performance will repair or replace defective products without charge during the first 12 months from the purchase date. No products will be considered for warranty without a copy of the purchase receipt showing the seller's name, address, and date of purchase. You must return the product to the dealer you purchased it from to initiate warranty procedures.

WIRE INDEX

- The index is listed in the same order in which the manual instructed components to be connected.
- The **BLUE** descriptions indicate sections found throughout the harness.
- **ORIGIN** indicates where the opposite end of this wire is.

FRONT LIGHT SECTION

Color	Gauge	Wire Print	Origin
Blue	18	#925 RIGHT FRONT TURN SIGNAL	Turn Switch
Light Blue	18	#926 LEFT FRONT TURN SIGNAL	Turn Switch
Tan	16	#909 HEADLIGHT LOW BEAM	Dimmer Switch
Tan	16	#909 HEADLIGHT LOW BEAM	Dimmer Switch
Brown	18	#927 FRONT PARK LIGHTS	Headlight Switch
Brown	18	#927 FRONT PARK LIGHTS	Headlight Switch
Light Green	16	#908 HEADLIGHT HIGH BEAM	Dimmer Switch
Light Green	16	#908 HEADLIGHT HIGH BEAM	Dimmer Switch
Green	14	#924 HORN	Horn Relay
Grey/White	18	TO COOLING FAN RELAY #901 TO COOLING FAN SWITCH	Fan Switch

ENGINE SECTION

Color	Gauge	Wire Print	Origin
Pink	14	#920 COIL + (IGNITION HOT)	Fuse Block
Light Green	18	TO TEMP SENDER << #921 >> TO TEMP GAUGE	Instrument Panel
Lt.Blue/Black	18	TO OIL SENDER << #922 >> TO OIL GAUGE	Instrument Panel
Purple/White	18	TO COIL (-) << #923 >> TO TACHOMETER	Instrument Panel
Red	18	#954 ELECTRIC CHOKE	Fuse Block
Black/White	14	TO A/C COMPRESSOR << #902 >> TO A/C HEAT SWITCH	Acc. Switches
Purple (10101 & 10103)	12	TO STARTER SOLENOID << #919 >> [NEUTRAL SAFETY SWITCH]	NSS
Purple (10102 & 10104)	12	TO STARTER SOLENOID << #919 >> [NEUTRAL SAFETY SWITCH]	Ignition Switch
Orange	14	#917 BRAKE SWITCH (POWER B+)	Fuse Block
White	16	#918 BRAKE SWITCH OUTPUT	Turn Switch

MIDI SECTION

Color	Gauge	Wire Print	Origin
Red	10	#916 BATTERY POWER SOURCE (MIDI FUSE)	Fuse Block

ALTERNATOR SECTION

Color	Gauge	Wire Print	Origin
White	14	#914 ALTERNATOR REGULATOR EXCITER	Fuse Block
Red	14	#995 ALT. REGULATOR POWER (BATTERY)	Fuse Block

DIMMER SWITCH SECTION

Color	Gauge	Wire Print	Origin
Light Green	14	#908 HIGH BEAM	Front Light Section
Tan	14	#909 LOW BEAM	Front Light Section
Blue/Yellow	14	[DIMMER SWITCH] << #907 >> DIMMER SWITCH POWER	Headlight Switch

HEADLIGHT SWITCH SECTION

Color	Gauge	Wire Print	Origin
Red/White	12	#928 HEADLIGHT SWITCH POWER (BAT)	Fuse Block
Orange	14	#959 HEADLIGHT SWITCH POWER (BAT)	Fuse Block
Blue/Yellow	14	[DIMMER SWITCH] << #907 >> DIMMER SWITCH POWER	Dimmer Switch
Brown	18	#927 FRONT PARK LIGHTS	Headlight Section
Brown	18	#930 INSTRUMENT PANEL LIGHTING	Instrument Panel
Brown	14	#929 TAILLIGHTS	Tail Section
Black	18	DOME LIGHT GROUND << #961 >> DOME/COURTESY LIGHT ACTIVATION	Tail Section

TURN SIGNAL SWITCH SECTION

Color	Gauge	Wire Print	Origin
White	14	#918 BRAKE SWITCH INPUT	Brake Switch
Blue	18	#925 RIGHT FRONT TURN SIGNAL	Front Light Section
Light Blue	18	#926 LEFT FRONT TURN SIGNAL	Front Light Section
Green	16	#948 RIGHT TURN / BRAKE	Tail Section
Yellow	16	#949 LEFT TURN / BRAKE	Tail Section
Brown	16	#951 HAZARD SWITCH POWER (BAT)	Fuse Block
Purple	16	#952 TURN SWITCH (TURN FLASHER)	Fuse Block
Black	18	#953 HORN SWITCH	Fuse Block

IGNITION SWITCH SECTION

Color	Gauge	Wire Print	Origin
Red	12	#934 IGNITION SWITCH POWER (BAT)	Fuse Block
Red (10201 & 10203)	12	#934 IGNITION SWITCH POWER (BAT)	Fuse Block
Orange	12	#933 SWITCHED (IGN) POWER TO FUSE BLOCK	Fuse Block
Brown	12	#932 ACCESSORY POWER	Fuse Block
Pink	14	#931 IGN POWER TO "COIL" FUSE	Fuse Block
Purple (10201 & 10203)	12	[IGNITION SWITCH] << #919 >> [NEUTRAL SAFETY SWITCH]	NSS
Purple (10202 & 10204)	12	TO STARTER SOLENOID << #919 >> [IGNITION SWITCH]	Starter/NSS

REVERSE SWITCH SECTION

Color	Gauge	Wire Print	Origin
Light Green	18	#958 REVERSE SWITCH POWER (IGN)	Fuse Block
Light Green	18	#956 OUTPUT TO REVERSE LIGHTS	Tail Section

NEUTRAL SAFETY SWITCH SECTION - (10201 & 10203)

Color	Gauge	Wire Print	Origin
Purple	12	TO STARTER SOLENOID << #919 >> [NEUTRAL SAFETY SWITCH]	Starter
Purple	12	[IGNITION SWITCH] << #919 >> [NEUTRAL SAFETY SWITCH]	Ignition Switch

CRUISE CONTROL

Color	Gauge	Wire Print	Origin
Pink	18	#957 CRUISE CONTROL SWITCH / ACC. POWER (IGN)	Ignition Switch

DRIVER DOOR SECTION

Color	Gauge	Wire Print	Origin
Yellow/Black	14	#912 DOOR LOCK POWER (BAT)	Ignition Switch
Yellow	14	#913 WINDOW POWER (IGN)	Ignition Switch

INSTRUMENT PANEL SECTION

Color	Gauge	Wire Print	Origin
Blue	18	#938 RIGHT TURN INDICATOR	Turn Switch
Light Blue	18	#937 LEFT TURN INDICATOR	Turn Switch
Red/White	18	#935 GAUGE POWER (IGN)	Fuse Block
Light Green	18	TO TEMP SENDER << #921 >> TO TEMP GAUGE	Engine Section
Lt.Blue/Black	18	TO OIL SENDER << #922 >> TO OIL GAUGE	Engine Section
Purple/White	18	TO COIL (-) << #923 >> TO TACHOMETER	Engine Section
Pink	18	FUEL SENDER << #939 >> FUEL GAUGE	Tail Section
Brown	18	#930 INSTRUMENT PANEL LIGHTING	Headlight Switch
Green	18	#936 HIGH BEAM INDICATOR	Dimmer Switch
Orange/Black	16	#955 ACCESSORY POWER (BAT)	Fuse Block

RADIO SECTION

Color	Gauge	Wire Print	Origin
Red	18	#940 (CONSTANT HOT)	Fuse Block
Red/Black	18	#941 RADIO POWER (SWITCHED)	Fuse Block
Purple/Black	18	#942 POWER ANTENNA / AMP (ACTIVATION WIRE)	Fuse Block

ACCESSORY SECTION B+

Color	Gauge	Wire Print	Origin
Grey/White	18	#906 COOLING FAN SWITCH (POWER B+)	Fuse Block
Black/White	14	#904 A/C HEAT SWITCH (POWER B+)	Fuse Block
Blue	16	#905 WIPER SWITCH (POWER B+)	Fuse Block
Tan	14	#903 CIGARETTE LIGHTER OR ACCESSORY (POWER B+)	Fuse Block

ACCESSORY SECTION SWITCHES

Color	Gauge	Wire Print	Origin
Grey/White	18	TO COOLING FAN RELAY #901 TO COOLING FAN SWITCH	Front Light Section
Black/White	14	TO A/C COMPRESSOR #902 TO A/C HEAT SWITCH	Engine Section

PASSENGER DOOR SECTION

Color	Gauge	Wire Print	Origin
Yellow/Black	14	#910 DOOR LOCK POWER (BAT)	Ignition Switch
Yellow	14	#911 WINDOW POWER (IGN)	Ignition Switch

TAIL SECTION

Color	Gauge	Wire Print	Origin
Yellow	16	#949 LEFT TURN / BRAKE	Turn Switch
Green	16	#948 RIGHT TURN / BRAKE	Turn Switch
Brown	16	#929 TAILLIGHT	Headlight Switch
Brown	16	#929 TAILLIGHT	Headlight Switch
Orange	18	#950 BRAKE LIGHT POWER (SEPARATE / 3RD BRAKE ONLY)	Brake Switch
Light Green	18	#956 REVERSE LIGHT	Reverse Switch
Light Green	18	#956 REVERSE LIGHT	Reverse Switch
Yellow/White	16	#947 ELECTRIC FUEL PUMP POWER (BAT)	Fuse Block
Pink	18	FUEL SENDER #939 FUEL GAUGE	Instrument Panel
White	18	#945 DOME LIGHT POWER (BAT)	Fuse Block
Black	18	DOME LIGHT GROUND #961 DOME / COURTESY LIGHT ACTIVATION	Ground
Green/Black	18	#946 TRUNK LIGHT / ACC. POWER (BAT)	Fuse Block
Purple/Black	18	#942 POWER ANTENNA / AMP (ACTIVATION WIRE)	Radio