

# AUXILIARY MAINSHAFT

# GMS-5966



<b>Description:</b>	AUXILIARY MAINSHAFT
<b>SKU:</b>	GMS-5966
<b>OEM:</b>	601KC442
<b>Product Group:</b>	TRANSMISSION
<b>Product Class:</b>	GEARS, SHAFTS, CLUTCHES
<b>UPC Code:</b>	193807236533
<b>Sell Pack:</b>	1 EA
<b>Weight:</b>	12.95 LBS
<b>Package Dimensions (LxWxH):</b>	5 x 5 x 10 inches
<b>Warranty:</b>	2 Years



**Details:**

This Auxiliay Mainshaft replaces Mack 601KC429 and 601KC432 Mainshafts.  
Mack T2080B, T2130, T2180, T313L, T318L Application

**E-Catalog Pages:**

Catalog Page	Description

Copyright © 2020 PAI Industries, Inc.  
All rights reserved. All content is property of PAI Industries, Inc, and may not be reproduced or redistributed in any form.

Any reference to OEM names or OEM product identification numbers/descriptions/model numbers is for identification only and does not indicate that it is an OEM part. PAI is not affiliated with Mack Truck, Inc.®, Volvo®, Fuller®, Cummins®, Eaton®, Rockwell®, Caterpillar®, Freightliner®, Hendrickson®, Kenworth®, Detroit Diesel®, International®, Peterbilt®, or Dana®. All Manufacturer's names, numbers, symbols and descriptions are used for reference only. It is not implied that any part listed is the product of these manufacturers.

## AUXILIARY MAINSHAFT

## GMS-5966

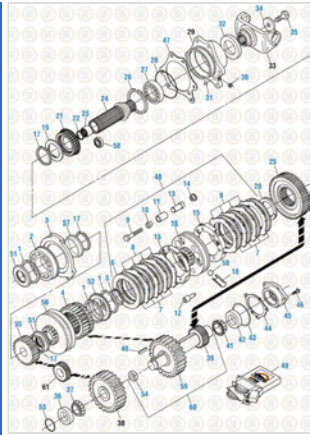

**Drive Train 2016**  
Rear Case Components - T2080B

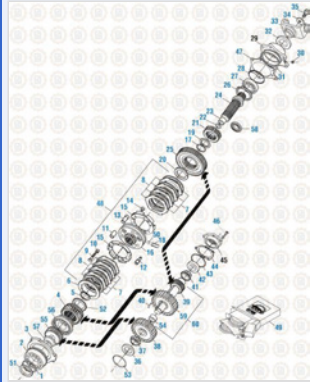

**Drive Train 2016**  
Rear Case Components - T2130 and T2180

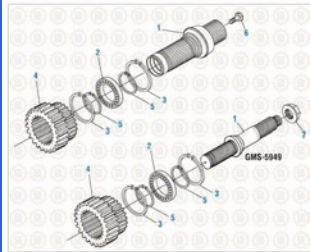

**Drive Train 2016**  
Auxiliary Mainshaft Update - T2130 and T2180

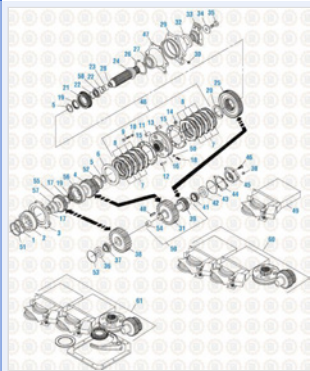

**Drive Train 2016**  
Rear Case Components - T313L and T318L

### Consists Of:

Copyright © 2020 PAI Industries, Inc.  
All rights reserved. All content is property of PAI Industries, Inc. and may not be reproduced or redistributed in any form.

Any reference to OEM names or OEM product identification numbers/descriptions/model numbers is for identification only and does not indicate that it is an OEM part. PAI is not affiliated with Mack Truck, Inc.®, Volvo®, Fuller®, Cummins®, Eaton®, Rockwell®, Caterpillar®, Freightliner®, Hendrickson®, Kenworth®, Detroit Diesel®, International®, Peterbilt®, or Dana®. All Manufacturer's names, numbers, symbols and descriptions are used for reference only. It is not implied that any part listed is the product of these manufacturers.

# AUXILIARY MAINSHAFT

# GMS-5966

SKU	OEM	Image	Description	Quantity
<a href="#">GMS-5966-001</a>	N/A	.	AUXILIARY MAINSHAFT	1
<a href="#">GRI-2836</a>	555AM7		RETAINING RING	3

Cross Reference:	
Manufacturer	OEM Number
MACK	601KC442
MACK	25130737

Copyright © 2020 PAI Industries, Inc.  
 All rights reserved. All content is property of PAI Industries, Inc, and may not be reproduced or redistributed in any form.

Any reference to OEM names or OEM product identification numbers/descriptions/model numbers is for identification only and does not indicate that it is an OEM part. PAI is not affiliated with Mack Truck, Inc.®, Volvo®, Fuller®, Cummins®, Eaton®, Rockwell®, Caterpillar®, Freightliner®, Hendrickson®, Kenworth®, Detroit Diesel®, International®, Peterbilt®, or Dana®. All Manufacturer's names, numbers, symbols and descriptions are used for reference only. It is not implied that any part listed is the product of these manufacturers.