

# RETAINING RING

# GRI-2824

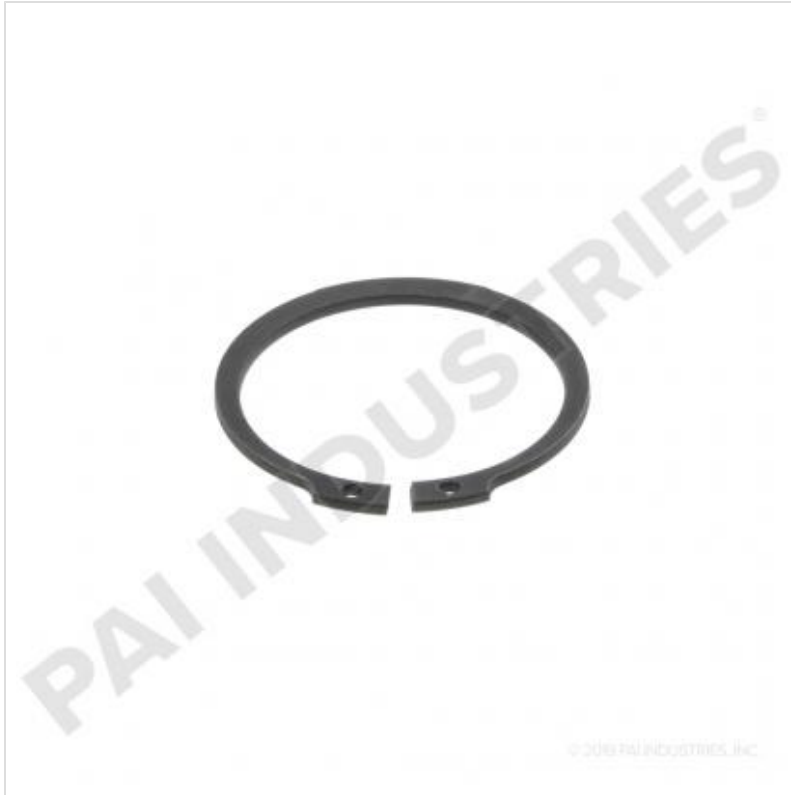

**Description:** RETAINING RING  
**SKU:** GRI-2824  
**OEM:** 555AM4  
**Product Group:** TRANSMISSION  
**Product Class:** GEARS, SHAFTS, CLUTCHES  
**UPC Code:** 193807197650  
**Sell Pack:** 5 EA  
 (Available to buy in increments of 5)  
**Weight:** 0.11 LBS  
**Warranty:** 2 Years

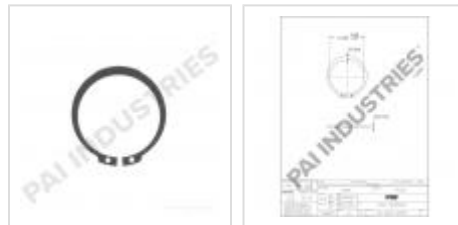

**Details:**

Retaining Ring  
 External  
 1.803in Free O.D. x 0.080in Thickness  
 45.79mm Free O.D. x 2.03mm Thickness

**E-Catalog Pages:**

Catalog Page	Description
	<p><b>Drive Train 2016</b>                      Main Case Components - T2080B</p>

Copyright © 2020 PAI Industries, Inc.  
 All rights reserved. All content is property of PAI Industries, Inc. and may not be reproduced or redistributed in any form.

Any reference to OEM names or OEM product identification numbers/descriptions/model numbers is for identification only and does not indicate that it is an OEM part. PAI is not affiliated with Mack Truck, Inc.®, Volvo®, Fuller®, Cummins®, Eaton®, Rockwell®, Caterpillar®, Freightliner®, Hendrickson®, Kenworth®, Detroit Diesel®, International®, Peterbilt®, or Dana®. All Manufacturer's names, numbers, symbols and descriptions are used for reference only. It is not implied that any part listed is the product of these manufacturers.

## RETAINING RING

## GRI-2824

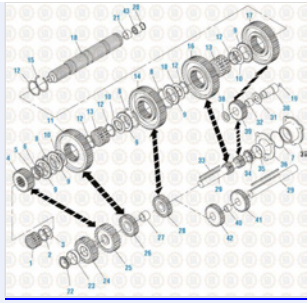

**Drive Train 2016**  
Main Case Components - T2080, T2090 and T2100

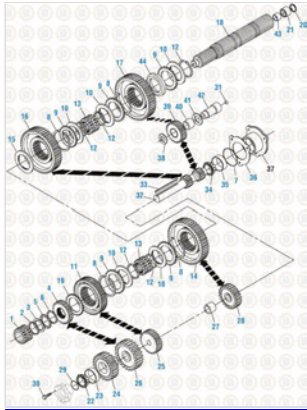

**Drive Train 2016**  
Main Case Components - T2060 & T2070

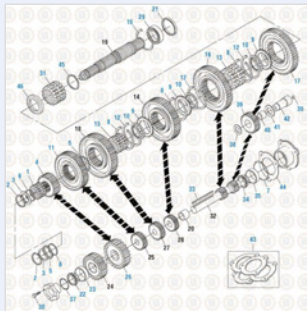

**Drive Train 2016**  
Main Case Components - T2060A

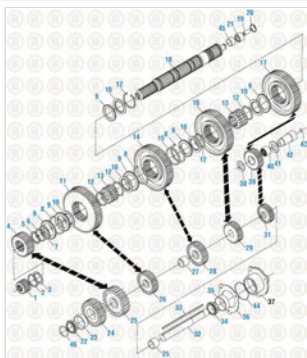

**Drive Train 2016**  
Main Case Components - T2130 and T2180

Copyright © 2020 PAI Industries, Inc.  
All rights reserved. All content is property of PAI Industries, Inc. and may not be reproduced or redistributed in any form.

Any reference to OEM names or OEM product identification numbers/descriptions/model numbers is for identification only and does not indicate that it is an OEM part. PAI is not affiliated with Mack Truck, Inc.®, Volvo®, Fuller®, Cummins®, Eaton®, Rockwell®, Caterpillar®, Freightliner®, Hendrickson®, Kenworth®, Detroit Diesel®, International®, Peterbilt®, or Dana®. All Manufacturer's names, numbers, symbols and descriptions are used for reference only. It is not implied that any part listed is the product of these manufacturers.

## RETAINING RING

## GRI-2824

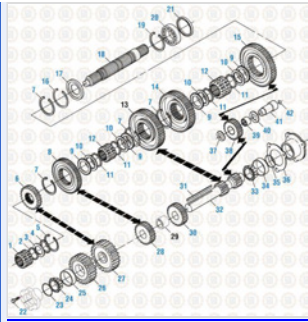

**Drive Train 2016**  
Main Case Components - Current Mainshaft Design - T2050

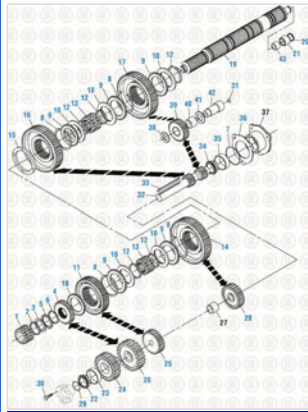

**Drive Train 2016**  
Main Case Components - T2070 A & C

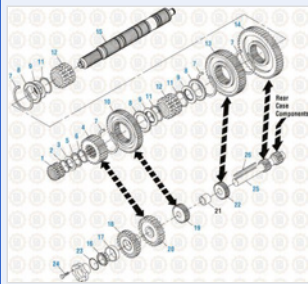

**Drive Train 2016**  
Main Case Components - Long Rear Case, Multi-Speed Reverse, Rear Mounted Main Shifter - T2070 B & D

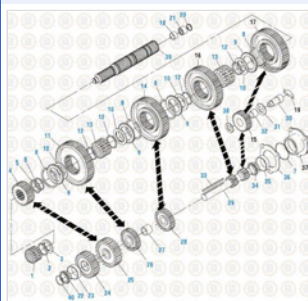

**Drive Train 2016**  
Main Case Components - T309L and T310

Copyright © 2020 PAI Industries, Inc.  
All rights reserved. All content is property of PAI Industries, Inc. and may not be reproduced or redistributed in any form.

Any reference to OEM names or OEM product identification numbers/descriptions/model numbers is for identification only and does not indicate that it is an OEM part. PAI is not affiliated with Mack Truck, Inc.®, Volvo®, Fuller®, Cummins®, Eaton®, Rockwell®, Caterpillar®, Freightliner®, Hendrickson®, Kenworth®, Detroit Diesel®, International®, Peterbilt®, or Dana®. All Manufacturer's names, numbers, symbols and descriptions are used for reference only. It is not implied that any part listed is the product of these manufacturers.

# RETAINING RING

# GRI-2824

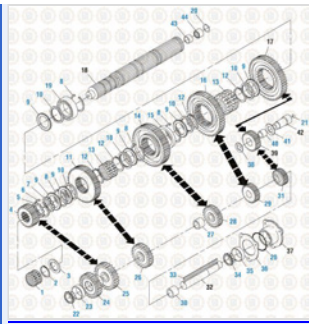

**Drive Train 2016**  
Main Case Components - T2110 B and D

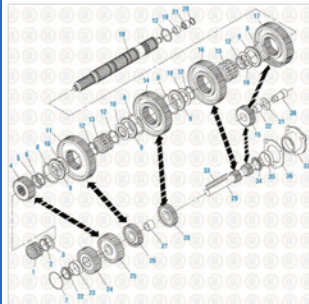

**Drive Train 2016**  
Main Case Components - T313L and T318L

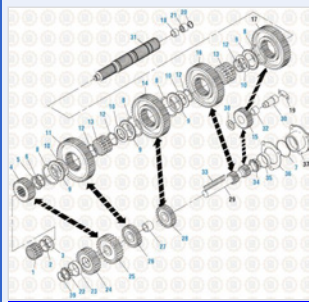

**Drive Train 2016**  
Main Case Components - T310M

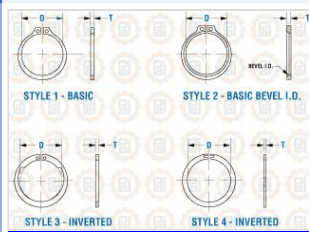

**Hardware**  
External - Basic and Inverted

**Component Of:**

SKU	Image	Description
<a href="#">GBK-5942</a>		BEARING AND SEAL KIT
<a href="#">GBK-6153</a>		BEARING AND SEAL KIT

Copyright © 2020 PAI Industries, Inc.  
All rights reserved. All content is property of PAI Industries, Inc. and may not be reproduced or redistributed in any form.

Any reference to OEM names or OEM product identification numbers/descriptions/model numbers is for identification only and does not indicate that it is an OEM part. PAI is not affiliated with Mack Truck, Inc.®, Volvo®, Fuller®, Cummins®, Eaton®, Rockwell®, Caterpillar®, Freightliner®, Hendrickson®, Kenworth®, Detroit Diesel®, International®, Peterbilt®, or Dana®. All Manufacturer's names, numbers, symbols and descriptions are used for reference only. It is not implied that any part listed is the product of these manufacturers.

# RETAINING RING

# GRI-2824

<a href="#">GBK-6565</a>		BEARING AND SEAL KIT
<a href="#">GBK-6573</a>		BEARING AND SEAL KIT
<a href="#">GMS-6648</a>		FRONT MAINSHAFT
<a href="#">GBK-8955-100</a>		RETAINING RING KIT
<a href="#">GBK-8956-100</a>		RETAINING RING KIT
<a href="#">GBK-8957</a>		BEARING AND SEAL KIT
<a href="#">GBK-8958-100</a>		RETAINING RING KIT
<a href="#">GBK-8963</a>		BEARING AND SEAL KIT
<a href="#">ERK-8997</a>		RING KIT
<a href="#">806870</a>		BEARING AND SEAL KIT

**Cross Reference:**

Manufacturer	OEM Number
MACK	25500885
MACK	555AM4

Copyright © 2020 PAI Industries, Inc.  
 All rights reserved. All content is property of PAI Industries, Inc. and may not be reproduced or redistributed in any form.

Any reference to OEM names or OEM product identification numbers/descriptions/model numbers is for identification only and does not indicate that it is an OEM part. PAI is not affiliated with Mack Truck, Inc.®, Volvo®, Fuller®, Cummins®, Eaton®, Rockwell®, Caterpillar®, Freightliner®, Hendrickson®, Kenworth®, Detroit Diesel®, International®, Peterbilt®, or Dana®. All Manufacturer's names, numbers, symbols and descriptions are used for reference only. It is not implied that any part listed is the product of these manufacturers.