

# EXTERNAL / SPIRAL RETAINING RING

## GRI-2797



**Description:** EXTERNAL / SPIRAL RETAINING RING  
**SKU:** GRI-2797  
**OEM:** 97AX260  
**Product Group:** TRANSMISSION  
**Product Class:** GEARS, SHAFTS, CLUTCHES  
**UPC Code:** 193807197179  
**Sell Pack:** 5 EA  
 (Available to buy in increments of 5)  
**Weight:** 0.21 LBS  
**Warranty:** 2 Years



**Details:**

External / Spiral Retaining Ring  
 2 Turn  
 2.722in Free I.D. x .188in Width x .093in Thick  
 69.13mm Free I.D. x 4.77mm Width x 2.36mm Thick  
 Multiple Use Applications

**E-Catalog Pages:**

Catalog Page	Description
	<p><b>Drive Train 2016</b>                      Input Shaft Components - T2080B</p>

Copyright © 2020 PAI Industries, Inc.  
 All rights reserved. All content is property of PAI Industries, Inc. and may not be reproduced or redistributed in any form.

Any reference to OEM names or OEM product identification numbers/descriptions/model numbers is for identification only and does not indicate that it is an OEM part. PAI is not affiliated with Mack Truck, Inc.®, Volvo®, Fuller®, Cummins®, Eaton®, Rockwell®, Caterpillar®, Freightliner®, Hendrickson®, Kenworth®, Detroit Diesel®, International®, Peterbilt®, or Dana®. All Manufacturer's names, numbers, symbols and descriptions are used for reference only. It is not implied that any part listed is the product of these manufacturers.

## EXTERNAL / SPIRAL RETAINING RING

GRI-2797

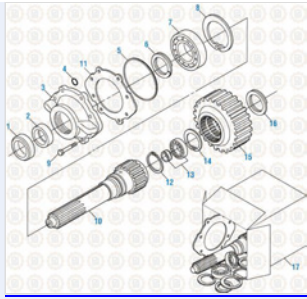
**Drive Train 2016**

Input Shaft - T2080, T2090 and T2100

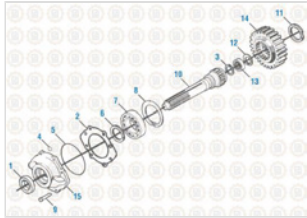
**Drive Train 2016**

Input Shaft Components - T2060A

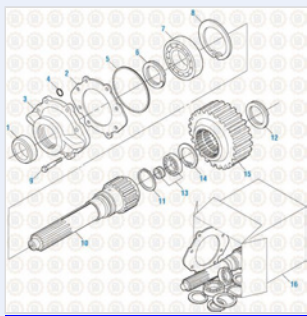
**Drive Train 2016**

Input Shaft Components - T2110 B and D

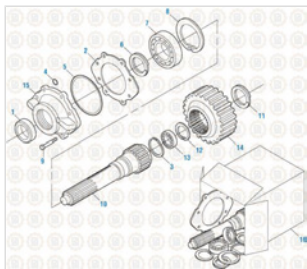
**Drive Train 2016**

Input Shaft Components - T2050

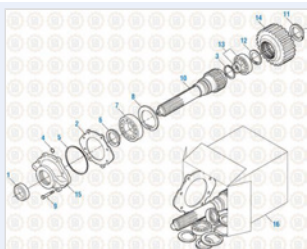
**Drive Train 2016**

Input Shaft Components - T2060 &amp; T2070

**Copyright © 2020 PAI Industries, Inc.**

All rights reserved. All content is property of PAI Industries, Inc. and may not be reproduced or redistributed in any form.

Any reference to OEM names or OEM product identification numbers/descriptions/model numbers is for identification only and does not indicate that it is an OEM part. PAI is not affiliated with Mack Truck, Inc.®, Volvo®, Fuller®, Cummins®, Eaton®, Rockwell®, Caterpillar®, Freightliner®, Hendrickson®, Kenworth®, Detroit Diesel®, International®, Peterbilt®, or Dana®. All Manufacturer's names, numbers, symbols and descriptions are used for reference only. It is not implied that any part listed is the product of these manufacturers.

## EXTERNAL / SPIRAL RETAINING RING

GRI-2797

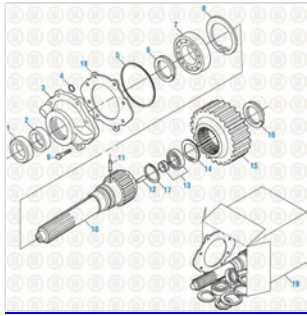

**Drive Train 2016**  
Input Shaft Components - T2130 and T2180

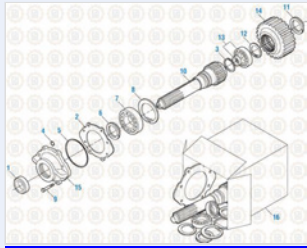

**Drive Train 2016**  
Input Shaft Components - T2070 A & C

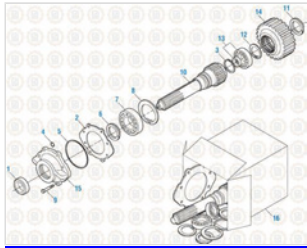

**Drive Train 2016**  
Input Shaft Components - T2070 B & D

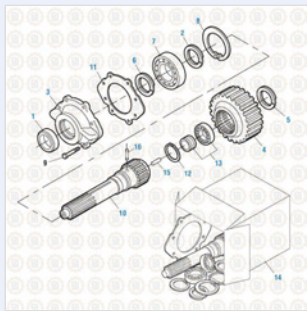

**Drive Train 2016**  
T309L and T310 - Input Shaft - T309L and T310

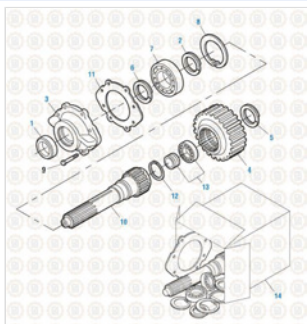

**Drive Train 2016**  
Input Shaft - T313L and T318L

Copyright © 2020 PAI Industries, Inc.  
All rights reserved. All content is property of PAI Industries, Inc. and may not be reproduced or redistributed in any form.

Any reference to OEM names or OEM product identification numbers/descriptions/model numbers is for identification only and does not indicate that it is an OEM part. PAI is not affiliated with Mack Truck, Inc.®, Volvo®, Fuller®, Cummins®, Eaton®, Rockwell®, Caterpillar®, Freightliner®, Hendrickson®, Kenworth®, Detroit Diesel®, International®, Peterbilt®, or Dana®. All Manufacturer's names, numbers, symbols and descriptions are used for reference only. It is not implied that any part listed is the product of these manufacturers.

# EXTERNAL / SPIRAL RETAINING RING

GRI-2797

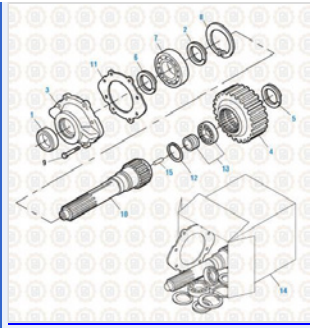

**Drive Train 2016**  
Input Shaft - T310M

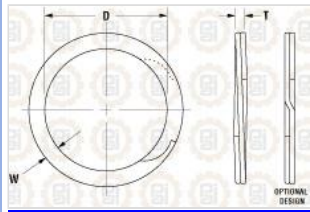

**Hardware**  
External - Spiral

**Component Of:**

SKU	Image	Description
<a href="#">GRK-2771</a>		RING KIT
<a href="#">GRK-2774</a>		RETAINING RING KIT
<a href="#">GBK-6573-100</a>	.	RETAINING RING KIT
<a href="#">GBK-8955-100</a>	.	RETAINING RING KIT
<a href="#">GBK-8956-100</a>	.	RETAINING RING KIT
<a href="#">ERK-8997</a>		RING KIT

Copyright © 2020 PAI Industries, Inc.  
All rights reserved. All content is property of PAI Industries, Inc. and may not be reproduced or redistributed in any form.

Any reference to OEM names or OEM product identification numbers/descriptions/model numbers is for identification only and does not indicate that it is an OEM part. PAI is not affiliated with Mack Truck, Inc.®, Volvo®, Fuller®, Cummins®, Eaton®, Rockwell®, Caterpillar®, Freightliner®, Hendrickson®, Kenworth®, Detroit Diesel®, International®, Peterbilt®, or Dana®. All Manufacturer's names, numbers, symbols and descriptions are used for reference only. It is not implied that any part listed is the product of these manufacturers.

## EXTERNAL / SPIRAL RETAINING RING

GRI-2797

[806850](#)

INPUT SHAFT KIT

**Cross Reference:**

Manufacturer	OEM Number
MACK	97AX260
MACK	25106992

Copyright © 2020 PAI Industries, Inc.

All rights reserved. All content is property of PAI Industries, Inc. and may not be reproduced or redistributed in any form.

Any reference to OEM names or OEM product identification numbers/descriptions/model numbers is for identification only and does not indicate that it is an OEM part. PAI is not affiliated with Mack Truck, Inc.®, Volvo®, Fuller®, Cummins®, Eaton®, Rockwell®, Caterpillar®, Freightliner®, Hendrickson®, Kenworth®, Detroit Diesel®, International®, Peterbilt®, or Dana®. All Manufacturer's names, numbers, symbols and descriptions are used for reference only. It is not implied that any part listed is the product of these manufacturers.