

RETAINING RING

GRI-2735

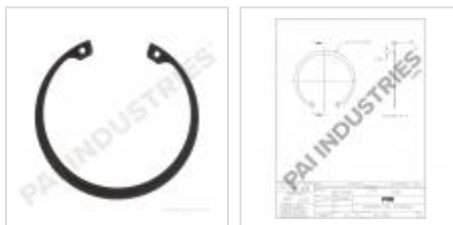

Description: RETAINING RING
SKU: GRI-2735
OEM: 97AX171
Product Group: TRANSMISSION
Product Class: GEARS, SHAFTS, CLUTCHES
UPC Code: 193807196158
Sell Pack: 10 EA
 (Available to buy in increments of 10)
Weight: 0.64 LBS
Warranty: 2 Years



Details:
 Internal Retaining Ring
 3.734 in Free O.D. x 0.109 In Thick
 94.84 mm Free O.D. x 2.76 mm Thick

Substitute:

SKU	Sell Pack	Weight	Warranty	Description
GRI-2785	5	0.33 LBS	2 Years	RING

E-Catalog Pages:

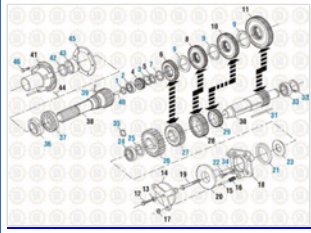
Catalog Page	Description
	<p>Web Electronic Main Case Components - Mack Transmission</p>

Copyright © 2020 PAI Industries, Inc.
 All rights reserved. All content is property of PAI Industries, Inc, and may not be reproduced or redistributed in any form.

Any reference to OEM names or OEM product identification numbers/descriptions/model numbers is for identification only and does not indicate that it is an OEM part. PAI is not affiliated with Mack Truck, Inc.®, Volvo®, Fuller®, Cummins®, Eaton®, Rockwell®, Caterpillar®, Freightliner®, Hendrickson®, Kenworth®, Detroit Diesel®, International®, Peterbilt®, or Dana®. All Manufacturer's names, numbers, symbols and descriptions are used for reference only. It is not implied that any part listed is the product of these manufacturers.

RETAINING RING

GRI-2735

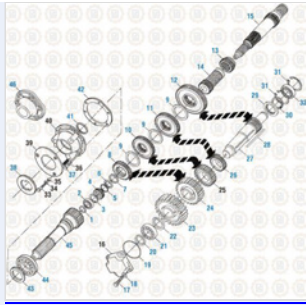

Web Electronic
Main Case Components - Mack Transmission

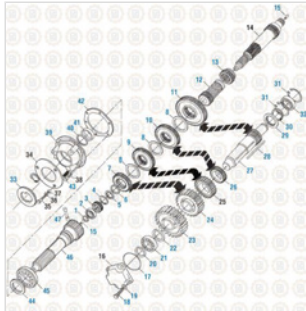

Web Electronic
Main Case Components - Mack Transmission

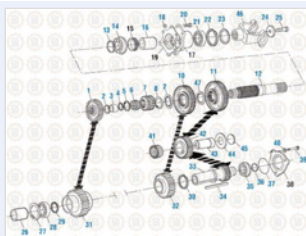

Web Electronic
Rear Components - Mack Transmission

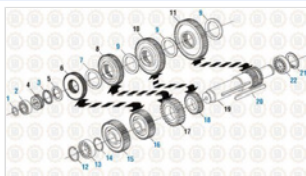

Web Electronic
Main Case Components - Mack Transmission

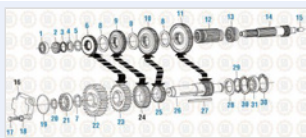

Web Electronic
Main Case Components - Mack Transmission

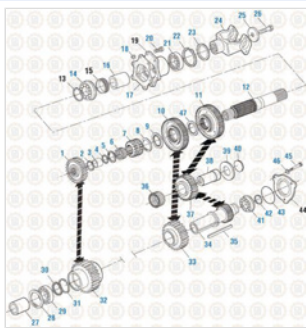

Web Electronic
Rear Case Components - Mack Transmission

Copyright © 2020 PAI Industries, Inc.
All rights reserved. All content is property of PAI Industries, Inc, and may not be reproduced or redistributed in any form.

Any reference to OEM names or OEM product identification numbers/descriptions/model numbers is for identification only and does not indicate that it is an OEM part. PAI is not affiliated with Mack Truck, Inc.®, Volvo®, Fuller®, Cummins®, Eaton®, Rockwell®, Caterpillar®, Freightliner®, Hendrickson®, Kenworth®, Detroit Diesel®, International®, Peterbilt®, or Dana®. All Manufacturer's names, numbers, symbols and descriptions are used for reference only. It is not implied that any part listed is the product of these manufacturers.

RETAINING RING

GRI-2735

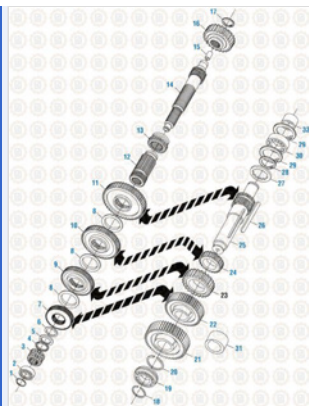

Drive Train 2016
Main Case Components - TRTXL-107/1070

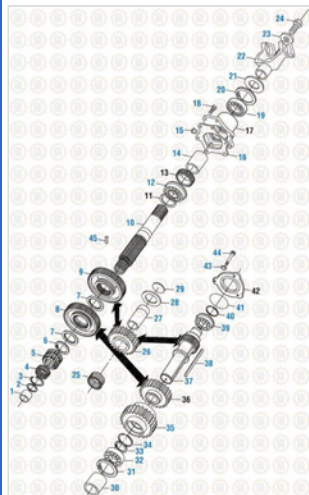

Drive Train 2016
Rear Case Components - TRTXL-107/1070

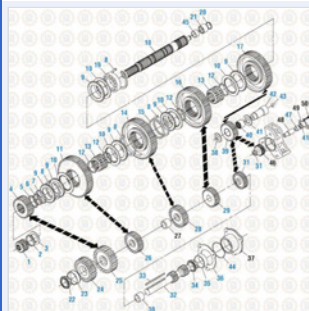

Drive Train 2016
Main Case Components - T2080B

Copyright © 2020 PAI Industries, Inc.
All rights reserved. All content is property of PAI Industries, Inc. and may not be reproduced or redistributed in any form.

Any reference to OEM names or OEM product identification numbers/descriptions/model numbers is for identification only and does not indicate that it is an OEM part. PAI is not affiliated with Mack Truck, Inc.®, Volvo®, Fuller®, Cummins®, Eaton®, Rockwell®, Caterpillar®, Freightliner®, Hendrickson®, Kenworth®, Detroit Diesel®, International®, Peterbilt®, or Dana®. All Manufacturer's names, numbers, symbols and descriptions are used for reference only. It is not implied that any part listed is the product of these manufacturers.

RETAINING RING

GRI-2735

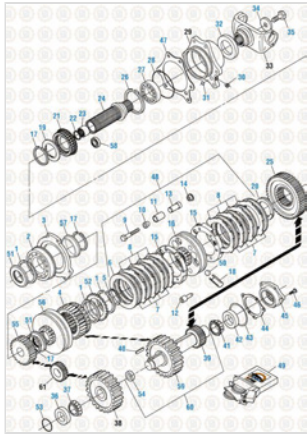

Drive Train 2016
Rear Case Components - T2080B

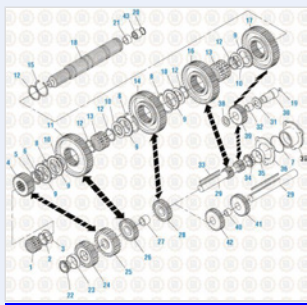

Drive Train 2016
Main Case Components - T2080, T2090 and T2100

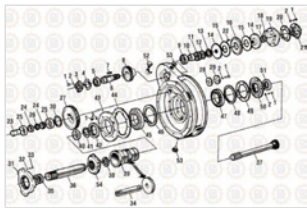

Web Electronic
Flywheel PTO Components - Mack Transmission

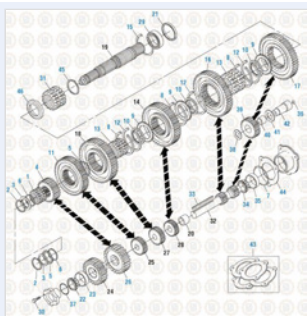

Drive Train 2016
Main Case Components - T2060A

Copyright © 2020 PAI Industries, Inc.
All rights reserved. All content is property of PAI Industries, Inc, and may not be reproduced or redistributed in any form.

Any reference to OEM names or OEM product identification numbers/descriptions/model numbers is for identification only and does not indicate that it is an OEM part. PAI is not affiliated with Mack Truck, Inc.®, Volvo®, Fuller®, Cummins®, Eaton®, Rockwell®, Caterpillar®, Freightliner®, Hendrickson®, Kenworth®, Detroit Diesel®, International®, Peterbilt®, or Dana®. All Manufacturer's names, numbers, symbols and descriptions are used for reference only. It is not implied that any part listed is the product of these manufacturers.

RETAINING RING

GRI-2735

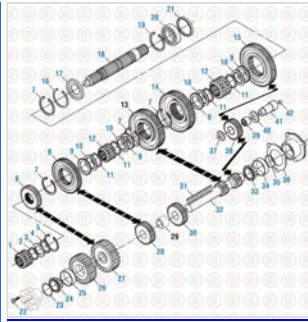
**Drive Train 2016**

Main Case Components - Current Mainshaft Design - T2050

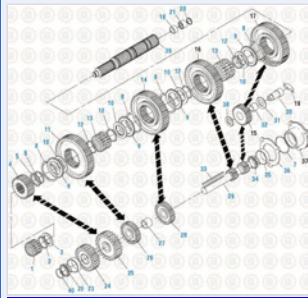
**Drive Train 2016**

Main Case Components - T309L and T310

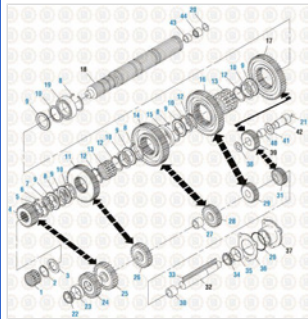
**Drive Train 2016**

Main Case Components - T2110 B and D

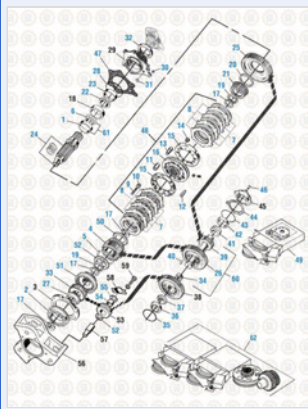
**Drive Train 2016**

Rear Case Components - T2110 B and D

Copyright © 2020 PAI Industries, Inc.

All rights reserved. All content is property of PAI Industries, Inc. and may not be reproduced or redistributed in any form.

Any reference to OEM names or OEM product identification numbers/descriptions/model numbers is for identification only and does not indicate that it is an OEM part. PAI is not affiliated with Mack Truck, Inc.®, Volvo®, Fuller®, Cummins®, Eaton®, Rockwell®, Caterpillar®, Freightliner®, Hendrickson®, Kenworth®, Detroit Diesel®, International®, Peterbilt®, or Dana®. All Manufacturer's names, numbers, symbols and descriptions are used for reference only. It is not implied that any part listed is the product of these manufacturers.

RETAINING RING

GRI-2735

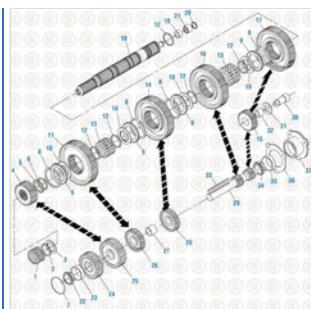

Drive Train 2016
Main Case Components - T313L and T318L

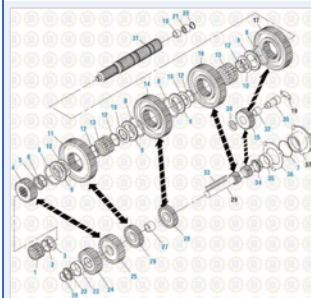

Drive Train 2016
Main Case Components - T310M

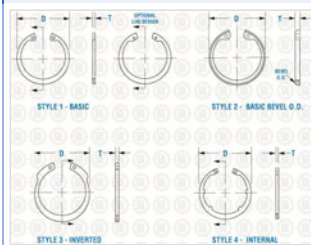

Hardware
Internal - Basic and Inverted

Component Of:

SKU	Image	Description
GRK-2774		RETAINING RING KIT
GRK-3973-100		O-RING KIT
GBK-6562-100		RETAINING RING KIT
GBK-6563-100		O-RING KIT
GBK-6565		BEARING AND SEAL KIT

Copyright © 2020 PAI Industries, Inc.
All rights reserved. All content is property of PAI Industries, Inc. and may not be reproduced or redistributed in any form.

Any reference to OEM names or OEM product identification numbers/descriptions/model numbers is for identification only and does not indicate that it is an OEM part. PAI is not affiliated with Mack Truck, Inc.®, Volvo®, Fuller®, Cummins®, Eaton®, Rockwell®, Caterpillar®, Freightliner®, Hendrickson®, Kenworth®, Detroit Diesel®, International®, Peterbilt®, or Dana®. All Manufacturer's names, numbers, symbols and descriptions are used for reference only. It is not implied that any part listed is the product of these manufacturers.

RETAINING RING

GRI-2735

GBK-6572-100	.	RING KIT
GBK-6573-100	.	RETAINING RING KIT
GBK-6685	.	BEARING AND SEAL KIT
GBK-8955-100	.	RETAINING RING KIT
GBK-8956-100	.	RETAINING RING KIT
GBK-8957	.	BEARING AND SEAL KIT
GBK-8963	.	BEARING AND SEAL KIT
ERK-8997		RING KIT
806870		BEARING AND SEAL KIT

Cross Reference:	
Manufacturer	OEM Number
MACK	25108495
MACK	97AX171

Copyright © 2020 PAI Industries, Inc.
 All rights reserved. All content is property of PAI Industries, Inc. and may not be reproduced or redistributed in any form.

Any reference to OEM names or OEM product identification numbers/descriptions/model numbers is for identification only and does not indicate that it is an OEM part. PAI is not affiliated with Mack Truck, Inc.®, Volvo®, Fuller®, Cummins®, Eaton®, Rockwell®, Caterpillar®, Freightliner®, Hendrickson®, Kenworth®, Detroit Diesel®, International®, Peterbilt®, or Dana®. All Manufacturer's names, numbers, symbols and descriptions are used for reference only. It is not implied that any part listed is the product of these manufacturers.